

Service Manual

Tumble dryer

T5350

Type N2...



PLATON SERVICE
8 (800) 500-34-47
www.platonservice.com



Electrolux



PLATONSERVICE

8 (800) 500-34-47

www.platonservice.com

Contents

Contents

1	Symbols	5
2	Technical data	6
2.1	Drawing	6
2.2	Technical data	7
2.3	Connections	7
3	Machine presentation	8
4	Function check	9
5	Sensors and overheating thermostats	10
5.1	Inlet air	10
5.1.1	Overheating thermostat	10
5.1.2	Heating sensor (PT100)	11
5.2	Outlet air	12
5.2.1	Overheating thermostat	12
5.2.2	Heating sensor (NTC-sensor)	13
5.3	Vacuum switch	13
6	Door	14
6.1	Door switch	14
6.2	Reversing the door	17
7	Motor	21
7.1	Replacement of motor	21
7.2	Replacement of fan motor	22
7.3	Replacement of fan	25
7.4	Replacement of motor pulley	27
7.5	Replacement of the belt around the motor pulley	29
7.6	Replacement of pulley	32
8	Heating unit, electric	34
8.1	General	34
8.2	Replacement of heating element	34
9	Heating unit, gas	36
9.1	Replacement of gas burner	36
9.2	Replacement of control box	37
9.3	Replacement of gas valve	38
9.4	Replacement of flame sensor	40
9.5	Replacement of ignition cable	41
9.6	Converting instructions	42
9.7	Table of pressure and adjustment	43
9.8	Test run	44
10	Heating unit, steam	45
10.1	Replacement of steam calorifier	45
10.2	Replacement of damper motor	46
11	Drum	47
11.1	Replacement of drum	47
11.2	Replacement of bearing	51
11.3	Replacement of the belt around the drum	55
11.4	Replacement of rear sealing	60
12	Control panel	66
12.1	Control system	66
12.1.1	Description	66
12.1.2	Connections	67
12.1.3	Replacement of control system CPU	68
12.2	Control knob	73
12.2.1	Replacement of control knob	73
13	I/O modules	76
13.1	General	76
13.2	Replacement of I/O module	78
13.3	External connections to I/O module type 2	79
13.4	Circuit diagram of function options for I/O module type 2	80
13.4.1	Central payment (2J)	80
13.4.2	Central payment (2J)	80
13.4.3	External coin meter/Central payment (2K)	81

Contents



13.4.4 Price reduction (2K).....	82
14 Troubleshooting	83
14.1 General.....	83
14.2 Error code	84
14.3 Description of error codes and causes	88
MAIN COMMON	88
MAIN WASHER	89
MAIN DRYER	94
MAIN BARRIER	100
MAIN W&D	103
MAIN DRYER	104
DRUM MOTOR COMMON.....	105
DRUM MOTOR EWD	106
DRUM MOTOR KEB	110
DRUM MOTOR OBIWAN.....	119
FAN MOTOR COMMON	122
INTERNAL COM.	123
INTERNAL COM. I/O TYPE 10.....	125
INTERNAL COM. I/O TYPE 6.....	127
EXTERNAL COM. PAYMENT	127
EXTERNAL COM. CMIS.....	128
INTERNAL.....	129
15 Maintenance	130
15.1 Clean the fan, the exhaust duct and the fresh-air intake to the room.....	130
15.2 Clean the glide surface for the RMC graphite collector	130
15.3 Clean the area around the drum.....	131
15.4 Clean the motors	133
15.5 Check the belt tension	134

The manufacturer reserves the right to make changes to design and component specifications.



PLATON SERVICE
8 (800) 500-34-41
www.platonservice.com

1 Symbols

	Caution
	Caution, hot surface
	Read the instructions before using the machine



PLATON SERVICE

8 (800) 500-34-41

www.platonservice.com

2 Technical data

2.1 Drawing

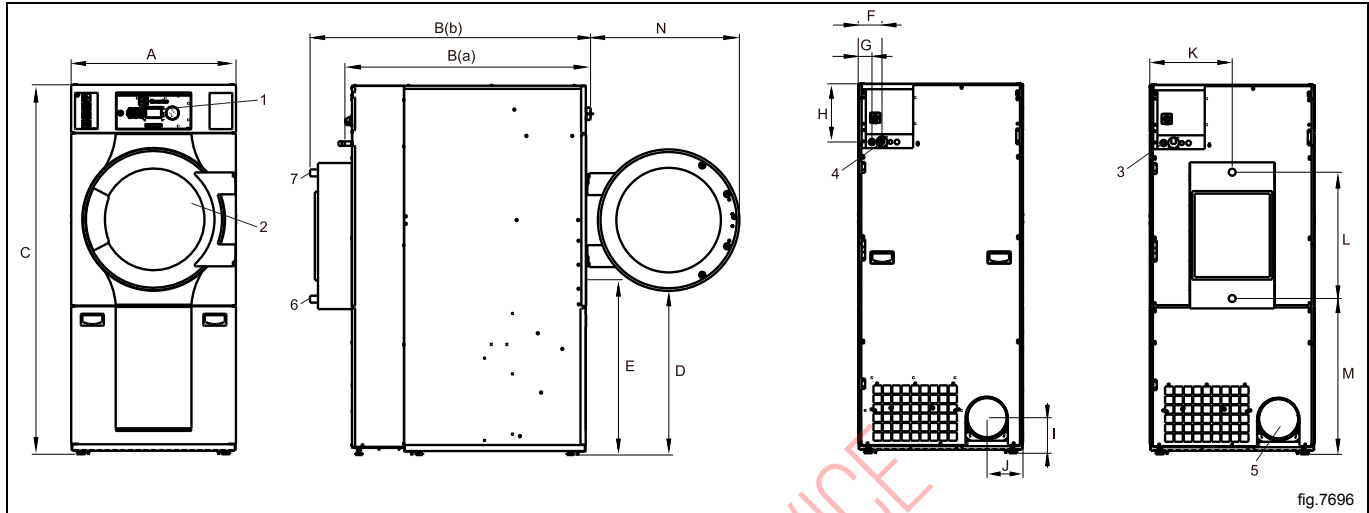

fig.7696

1	Operating panel
2	Door opening, \varnothing 580 mm
3	Electrical connection
4	Gas connection
5	Exhaust connection
6	Steam: in
7	Steam: out

	A	B (a)	B (b)	C	D	E
mm	790	1177	1344	1770	785	840

	F	G	H	I	J	K
mm	108	66	278	171	172	395

	L	M
mm	605	747

2.2 Technical data

Weight, net	kg	177
Weight, net, Steam	kg	184
Drum volume	litres	349
Drum diameter	mm	760
Drum depth	mm	770
Drum speed, medium load	rpm	45
Rated capacity, filling factor 1:18 (Max. load)	kg	19.4
Rated capacity, filling factor 1:22 (Recommended load)	kg	15.5
Heating: Electricity	kW	13.2
	kW	13.5
	kW	18.0
Heating: Gas	kW	21.0
Heating: Steam at 800 kPa	kW	25.0
Steam pressure	kPa	100–1000
Electric heating, 13.5 kW Maximum air flow	m ³ /h	1000
Electric heating, 18 kW Maximum air flow	m ³ /h	1000
Gas heating Maximum air flow	m ³ /h	1000
Steam heating Maximum air flow	m ³ /h	1000
Maximum static back pressure, Electric 13.5 kW	Pa	520
Maximum static back pressure, Electric 18 kW	Pa	270
Maximum static back pressure, Gas	Pa	270
Maximum static back pressure, Steam	Pa	270
Sound power/pressure level at drying*	dB(A)	74/58

* Sound power levels measured according to ISO 60704.

2.3 Connections

Air outlet	∅ mm	200
Gas connection	1/2"	ISO 7/1–R1/2
Steam inlet/outlet		ISO 7/1–R1

3 Machine presentation

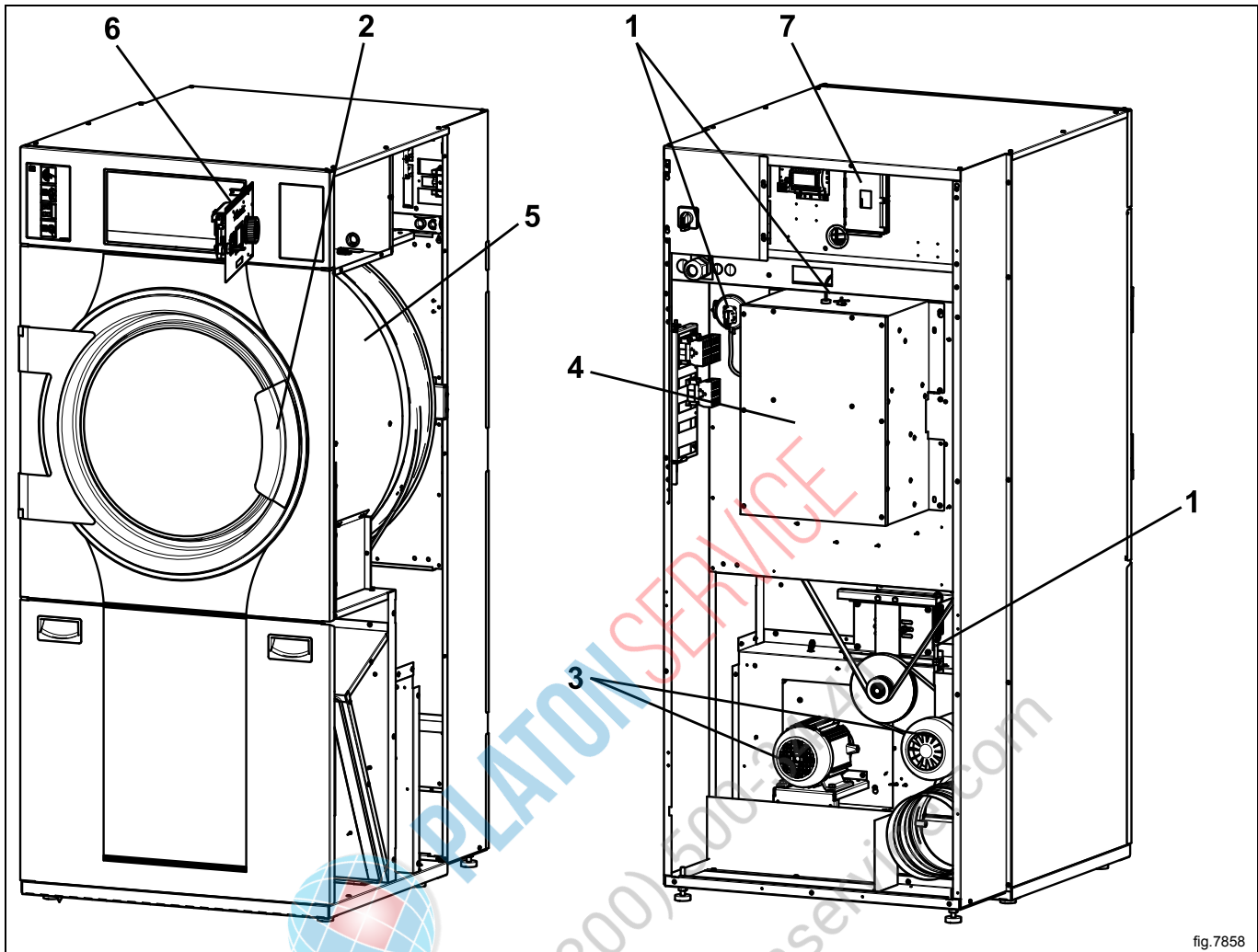

fig.7858

1	Sensors and overheating thermostats
2	Door
3	Motor
4	Heating unit
5	Drum
6	Control panel with Control system
7	I/O modules

After a repair has been made

Whenever a repair has been made, a function check must be performed before the machine can be used again.

4 Function check



May only be carried out by qualified personnel.



A function check must be made when the installation is finished and before the machine can be ready to be used. Whenever a repair has been made, a function check must be performed before the machine can be used again.

Check the automatic stop of the machine

- Start the machine.
- Check if the micro switches are working properly:
The machine must stop if the door is opened.

Check the direction of rotation (only on machines with 3-phase power supply)

- Check that the direction of the fan wheel is correct.

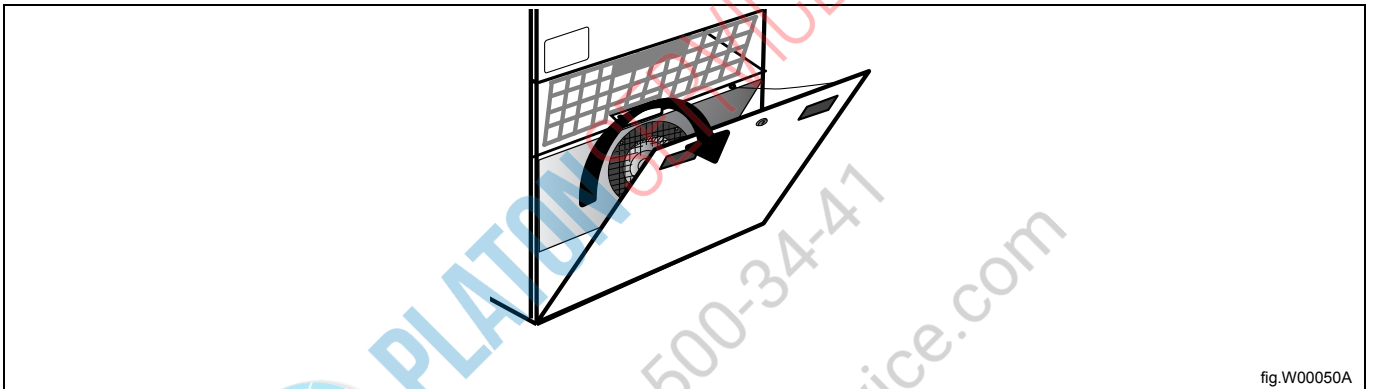

fig.W00050A

If the direction is wrong, swap two of the three phases to the left on the connection terminal.

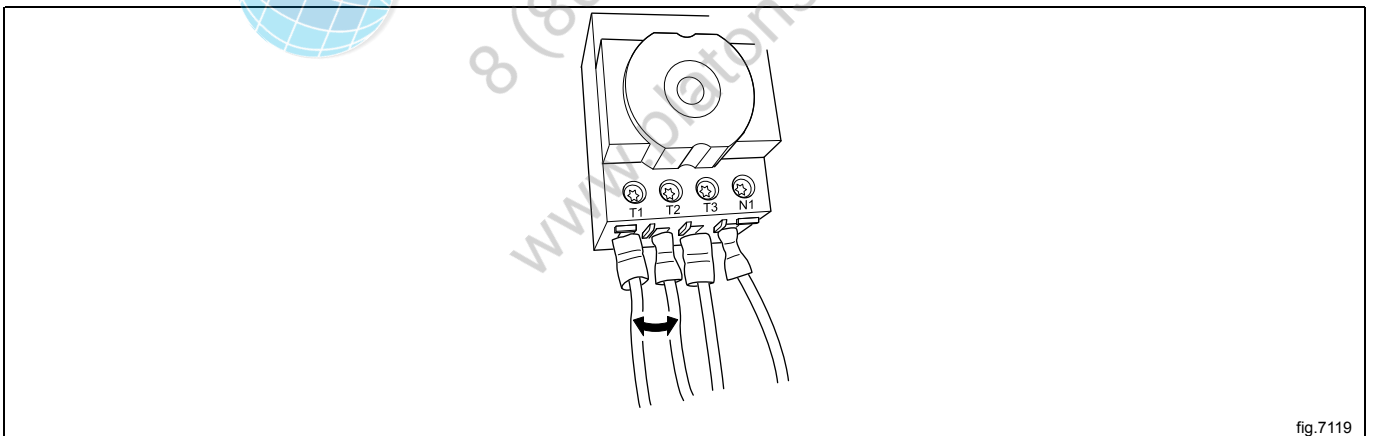

fig.7119

Check the heat

- Let the machine work for five minutes on a program with heat.
- Check that the heating is working by opening the door and feel if there is heat in the drum.

Ready to use

If all tests are OK the machine is now ready to be used.

If some of the tests failed, or deficiencies or errors are detected, please contact your local service organisation or dealer.

The installer shall instruct the user on the operation of the appliance before leaving.

5 Sensors and overheating thermostats

5.1 Inlet air

5.1.1 Overheating thermostat

Description

The inlet overheating thermostat is placed on the heating module on the back of the machine. The inlet overheating thermostat opens in the event of overheating and shuts off the machine.

Resetting

Disconnect the power to the machine. Gas heated machine: Shut off the manual gas valve.

Demount the rear panel.

Press the reset button (A) on the overheating thermostat.

Note!

Resetting must not be done before the cause for overheating is verified and resolved.

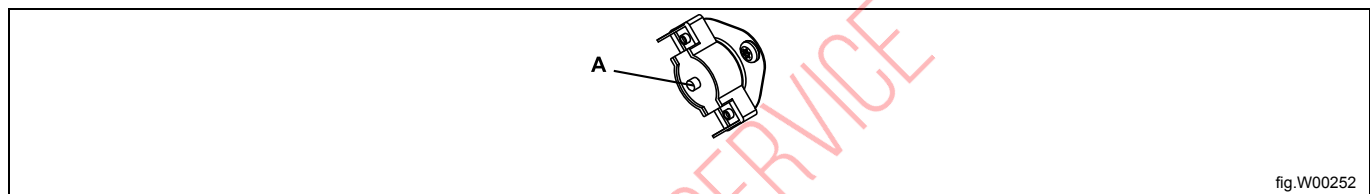

Remount the rear panel.

Replacement of overheating thermostat

Disconnect the power to the machine. Gas heated machine: Shut off the manual gas valve.

Demount the rear panel.

Disconnect the overheating thermostat and remove it. Connect the new overheating thermostat.

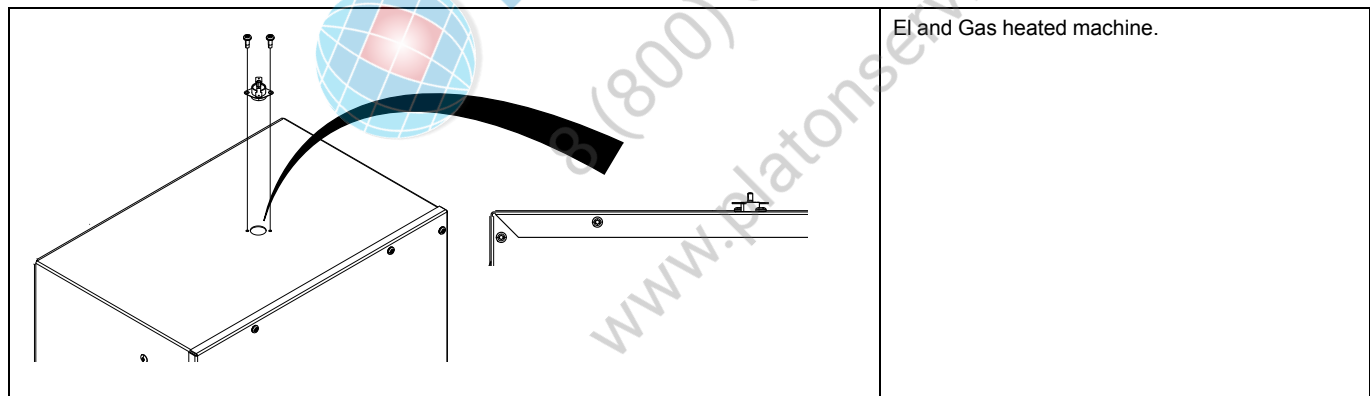

Remount the rear panel.

5.1.2 Heating sensor (PT100)

Description

The heating sensor is placed on the heating module on the back of the machine.

The heating sensor measures the temperature in the inlet air and the signal is returned to the CPU.

The CPU turns the heating unit off when the inlet air thermistor indicates that the required temperature has been reached.

Replacement of heating sensor (PT100)

Disconnect the power to the machine. Gas heated machine: Shut off the manual gas valve.

Demount the rear panel.

Disconnect the heating sensor and remove it. Connect the new heating sensor and put it in position. Make sure the sensor gets all the way down.

	<p>EI and Gas heated machine.</p>
	<p>Steam heated machine.</p>

Remount the rear panel.

5.2 Outlet air

5.2.1 Overheating thermostat

Description

The outlet overheating thermostat is placed behind the lint filter next to the fan on the front of the machine. The outlet overheating thermostat ensures that the machine does not overheat during program operation. The outlet overheating thermostat opens automatically and has to be reset manually.

Resetting

Disconnect the power to the machine. Gas heated machine: Shut off the manual gas valve.
Remove the filter door.
Remove the lint filter and demount the panel.
Press the reset button (A) on the overheating thermostat.

Note!

Resetting must not be done before the cause for overheating is verified and resolved.

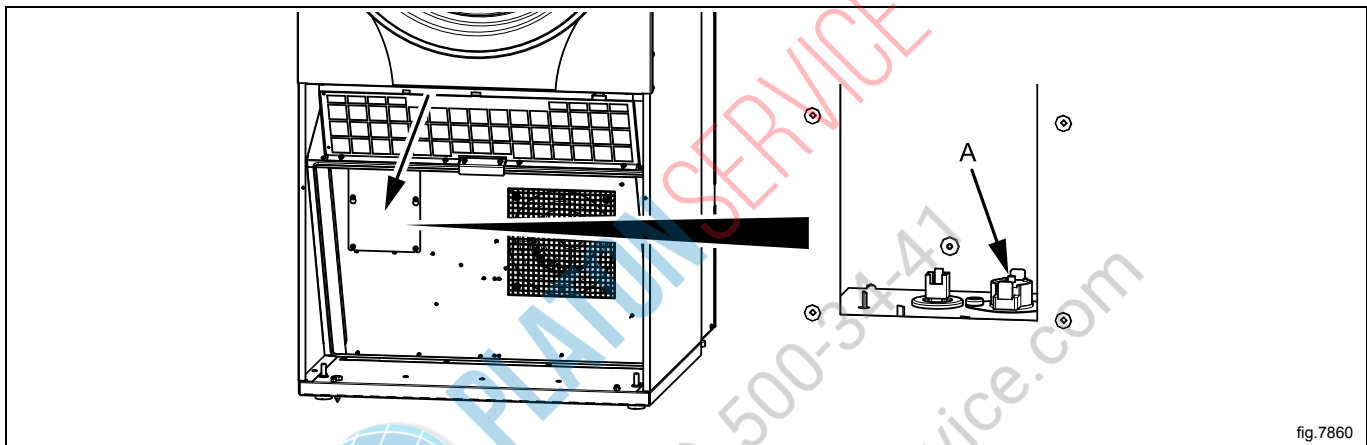

fig.7860

Remount the panel, lint filter and the filter door.

Replacement of overheating thermostat

Disconnect the power to the machine. Gas heated machine: Shut off the manual gas valve.
Remove the filter door.
Remove the lint filter and demount the panel.
Disconnect the overheating thermostat and remove it. Connect the new overheating thermostat.

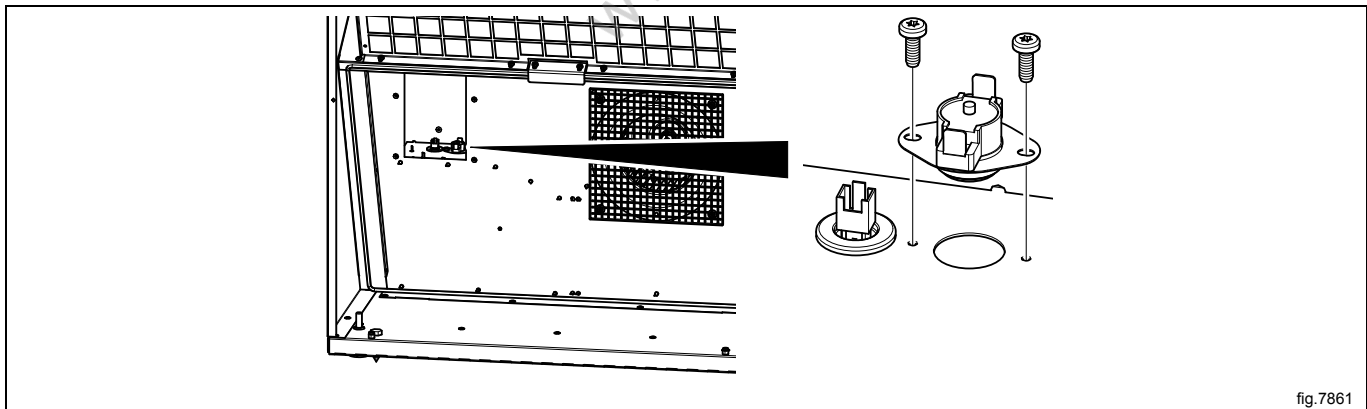

fig.7861

Remount the panel, lint filter and the filter door.

5.2.2 Heating sensor (NTC-sensor)

Description

The heating sensor is placed behind the lint filter next to the fan on the front of the machine.

The heating sensor measures the temperature in the outlet air and the signal is returned to the PCB.

The PCB turns the heating unit off when the outlet air thermistor indicates that the required temperature has been reached.

Replacement of heating sensor (NTC-sensor)

Disconnect the power to the machine. Gas heated machine: Shut off the manual gas valve.

Remove the filter door.

Remove the lint filter and demount the panel.

Disconnect the heating sensor and remove it. Connect the new heating sensor and put it in position. Make sure the sensor gets all the way in.

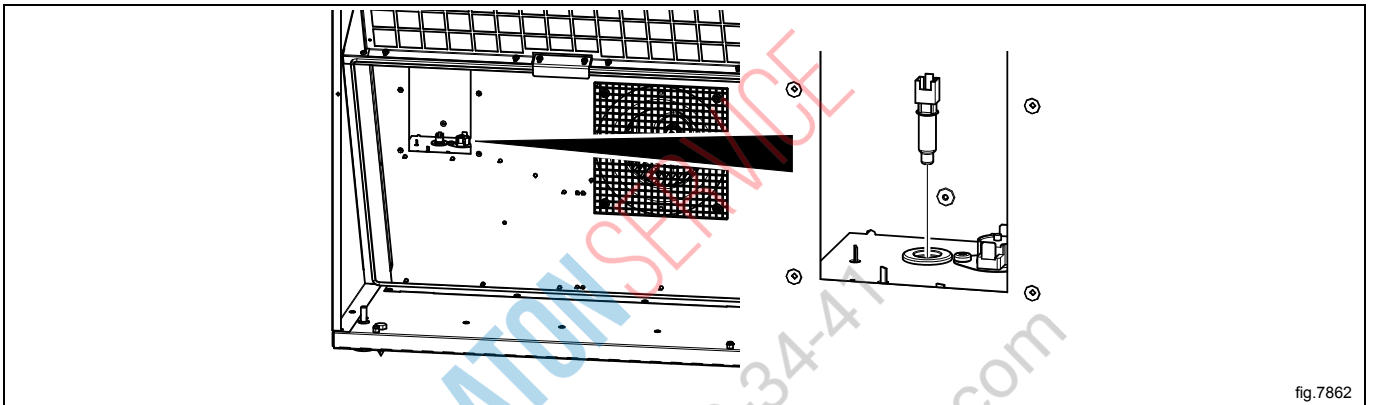

fig.7862

Remount the panel, lint filter and the filter door.

5.3 Vacuum switch

Function

The vacuum switch is placed next to the heating module on the back of the machine.

The vacuum switch ensures the necessary airflow in the machine.

Replacement of vacuum switch

Disconnect the power to the machine. Gas heated machine: Shut off the manual gas valve.

Demount the rear panel.

Disconnect the wires to the vacuum switch. Disconnect the vacuum hose. **Note the position of the wires.**

Remove the screws (A) and disconnect the vacuum switch.

Connect the new vacuum switch. Connect the vacuum hose and the wires. **Make sure that the art. No. on the new vacuum switch is the same as the old one.**

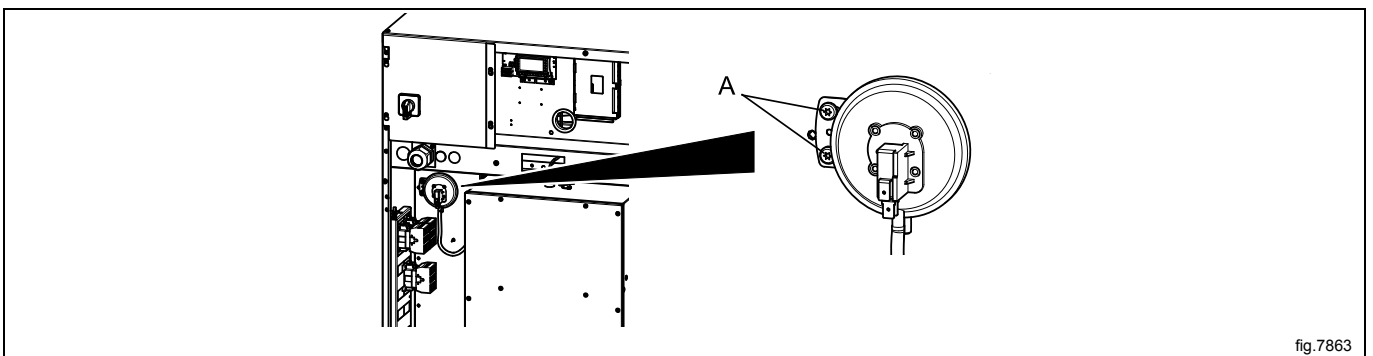

fig.7863

Remount the rear panel.

6 Door

6.1 Door switch

The door switch (A) ensures that the machine stops automatically if the door is opened during operation.

If the machine does not stop when the door is opened or if the door is closed and the error code `DOOR IS OPEN` is displayed (and the machine is unable to start), for example, the door switch needs to be replaced.

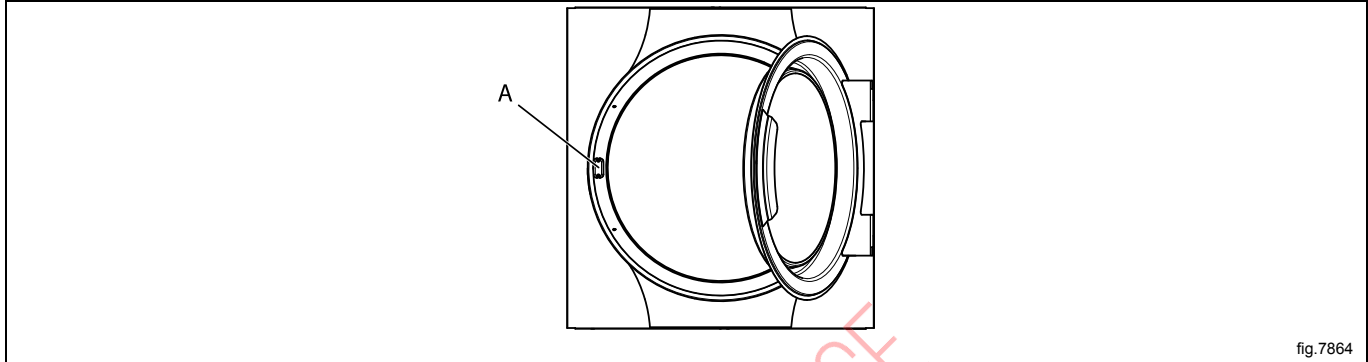

Replacement of door switch

Disconnect the power to the machine.

Demount the hinges and remove the door. Remove the upper hinge first.

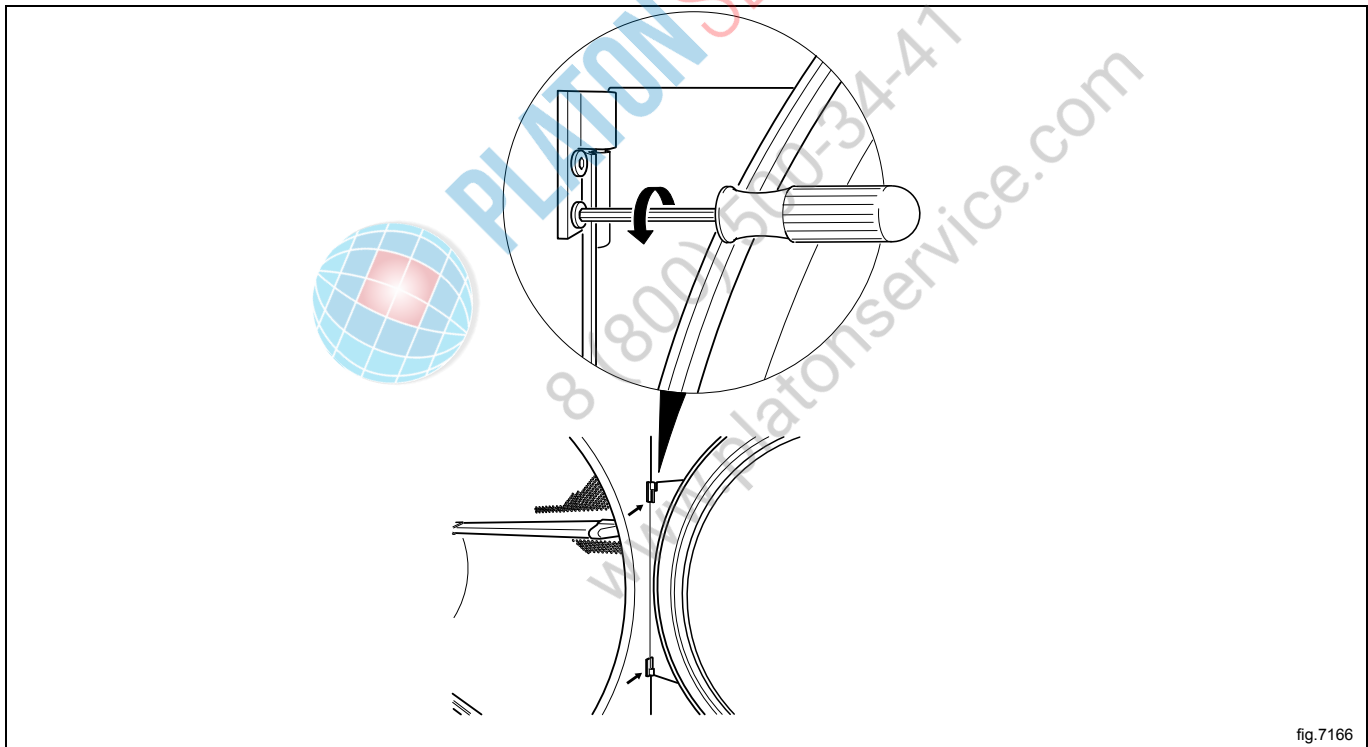

Remove the screws on the front panel and carefully loosen the panel. Push the door switch cable down through the hole in order to access the cable and then disconnect the cable. Remove the panel.

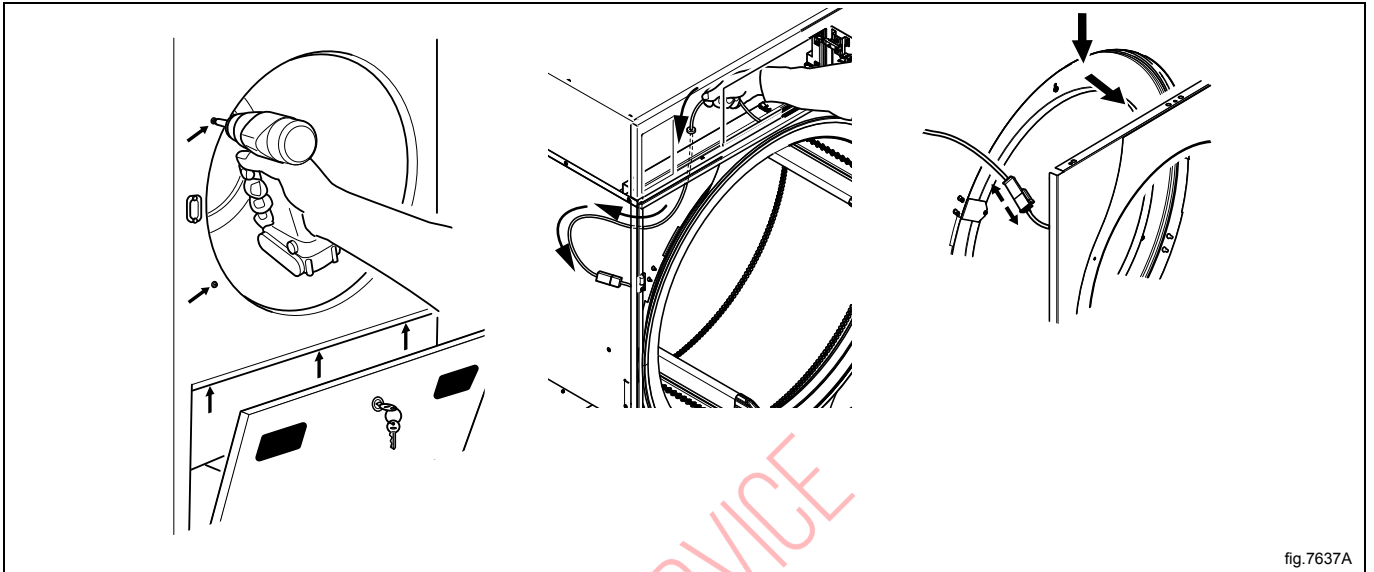
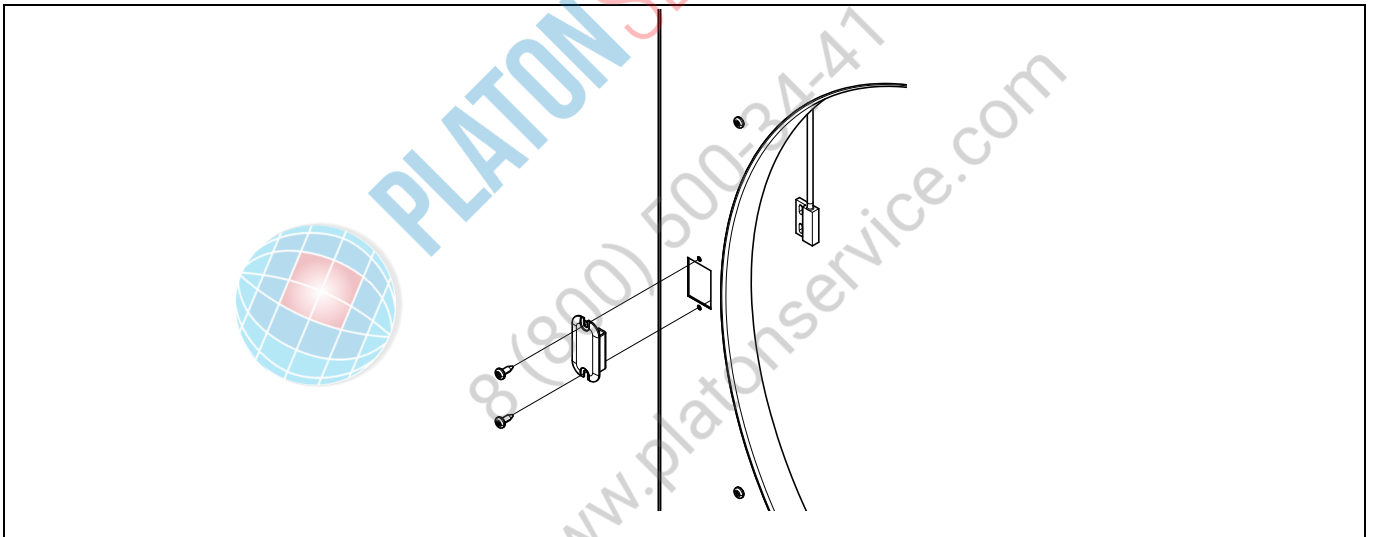
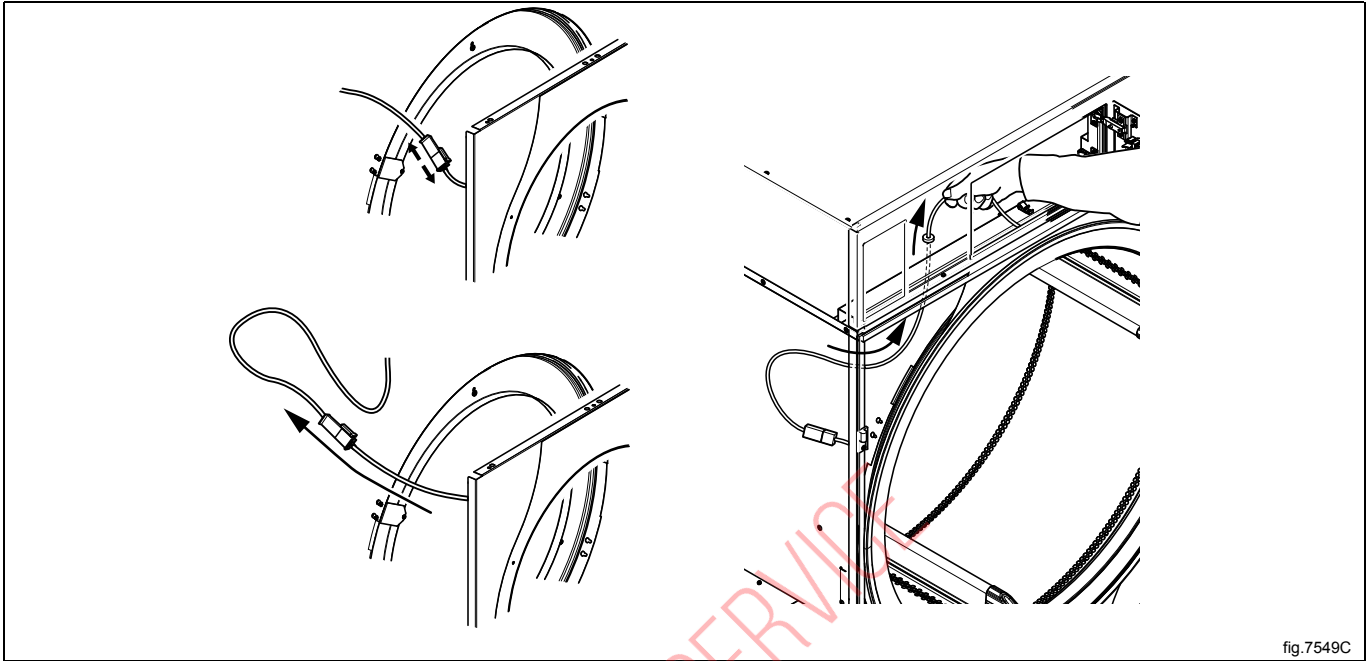

fig.7637A

Remove the door switch and door switch cable and mount the new one.



Connect the door switch cable and push the cable in over the drum and pull it upwards.



Remount the front panel.



Ensure that the door switch cable does not get damaged when remounting the front panel.



Replacement of door magnets

Remove the magnet to be replaced and mount the new one.

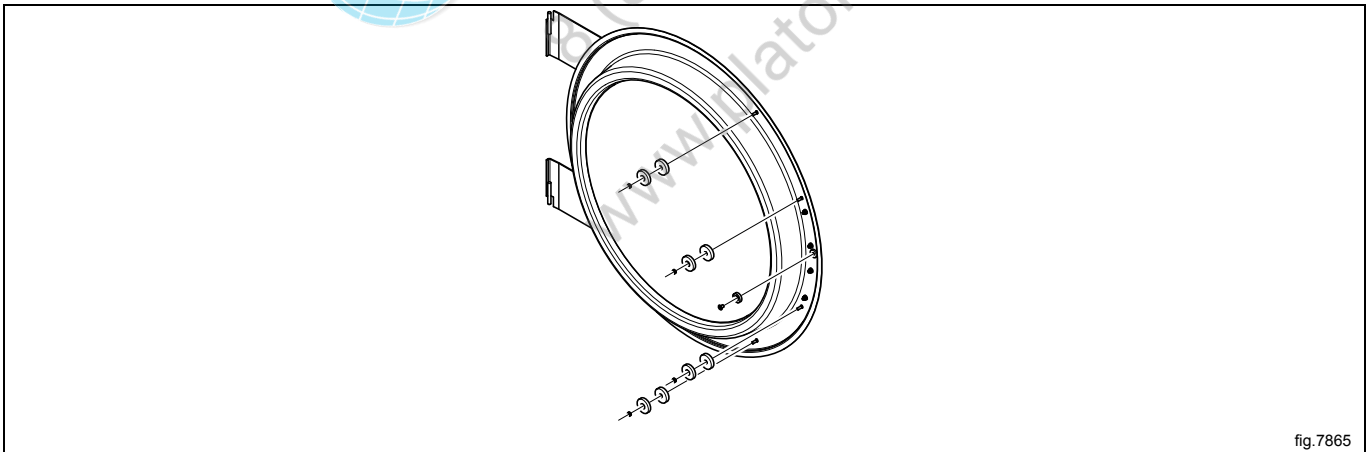

6.2 Reversing the door

Disconnect the power to the machine.

Demount the hinges and remove the door. Remove the upper hinge first.

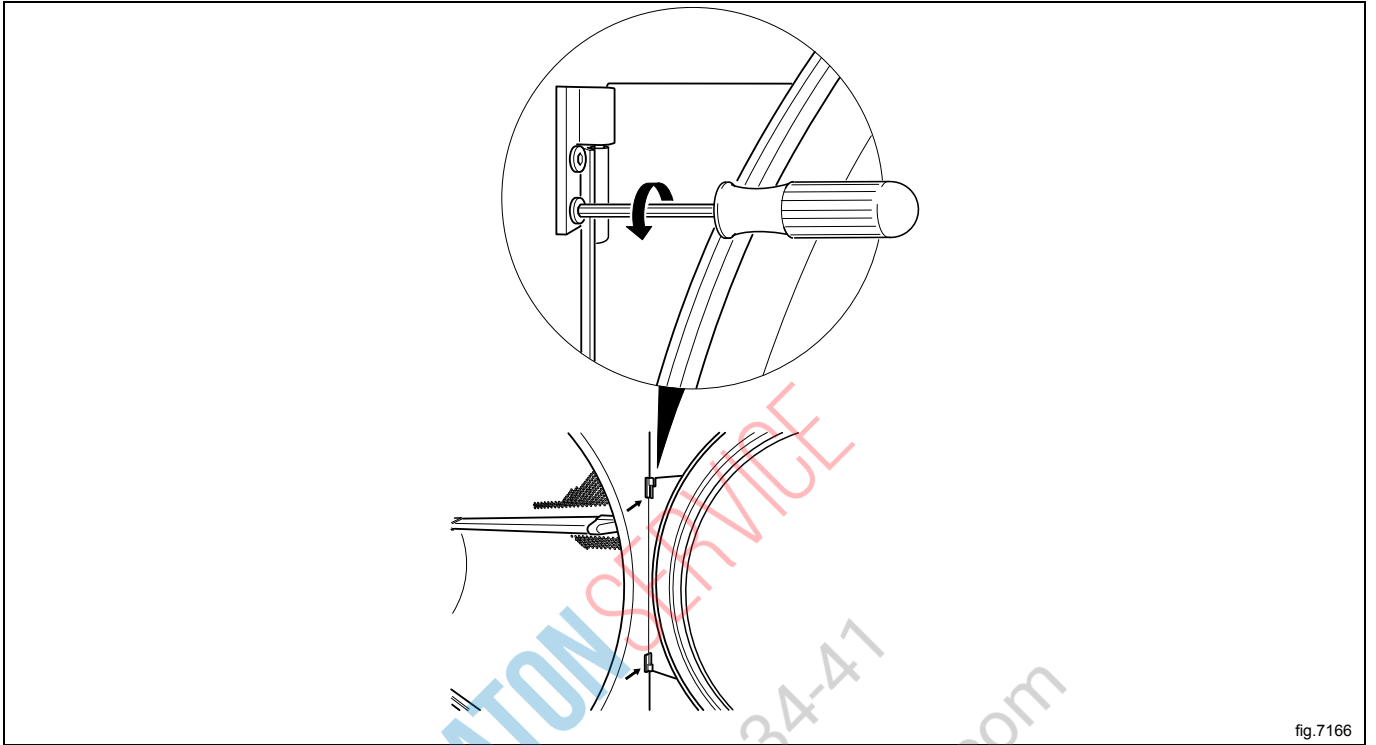

fig.7166

Remove the screws on the front panel and carefully loosen the panel. Push the door switch cable down through the hole in order to access the cable and then disconnect the cable. Remove the panel.

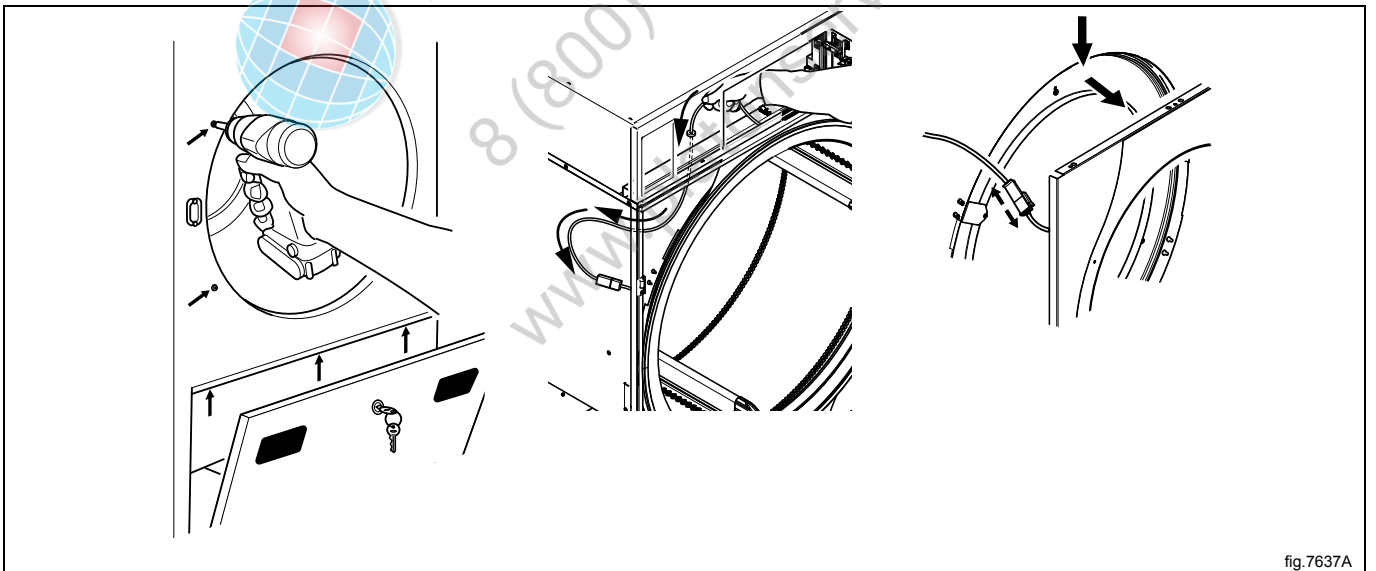

fig.7637A

Move the door switch cable to the opposite side.

Note!

The plastic plug **MUST** be placed in the hole where the door switch cable was before.

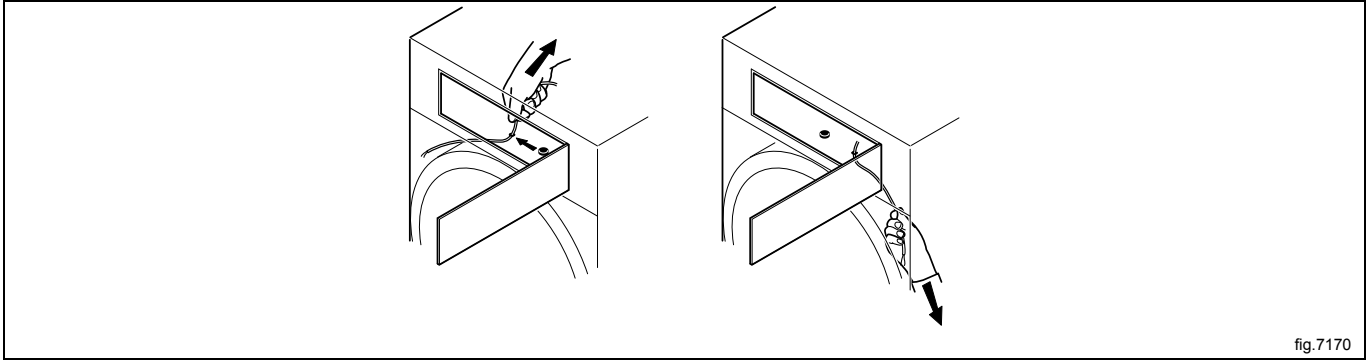

fig.7170

Loosen the nuts and move the two brackets to the opposite side.

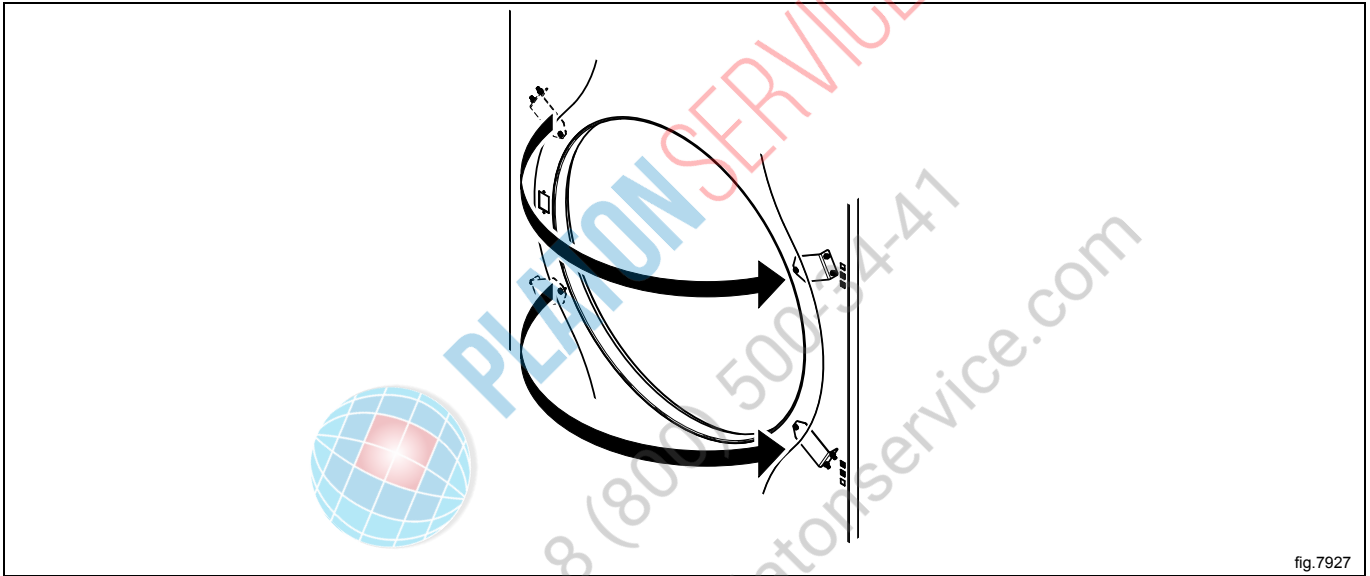

fig.7927

Move the door switch on the front panel.

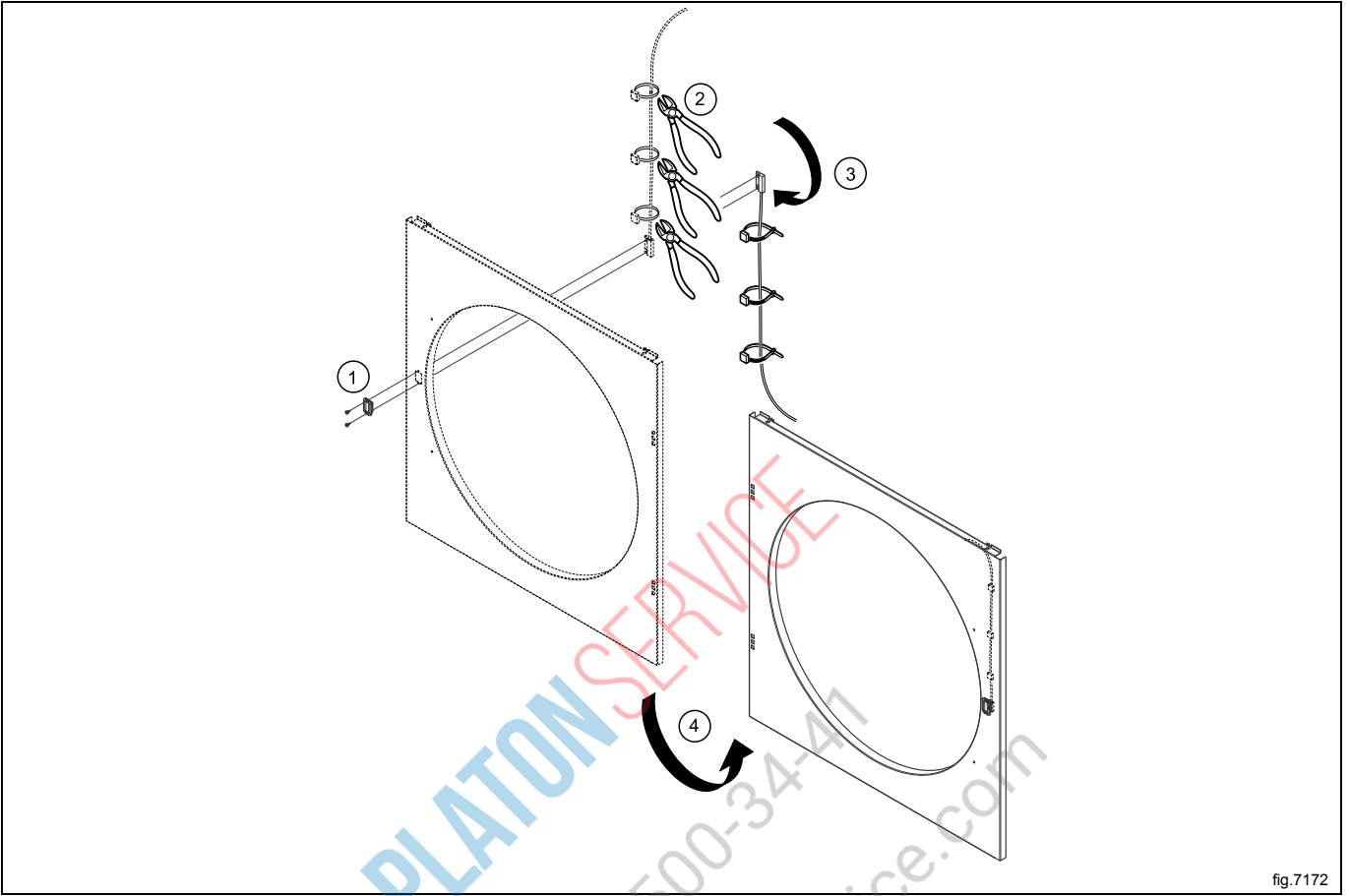

fig.7172

Move the four metal clips from the opposite side.

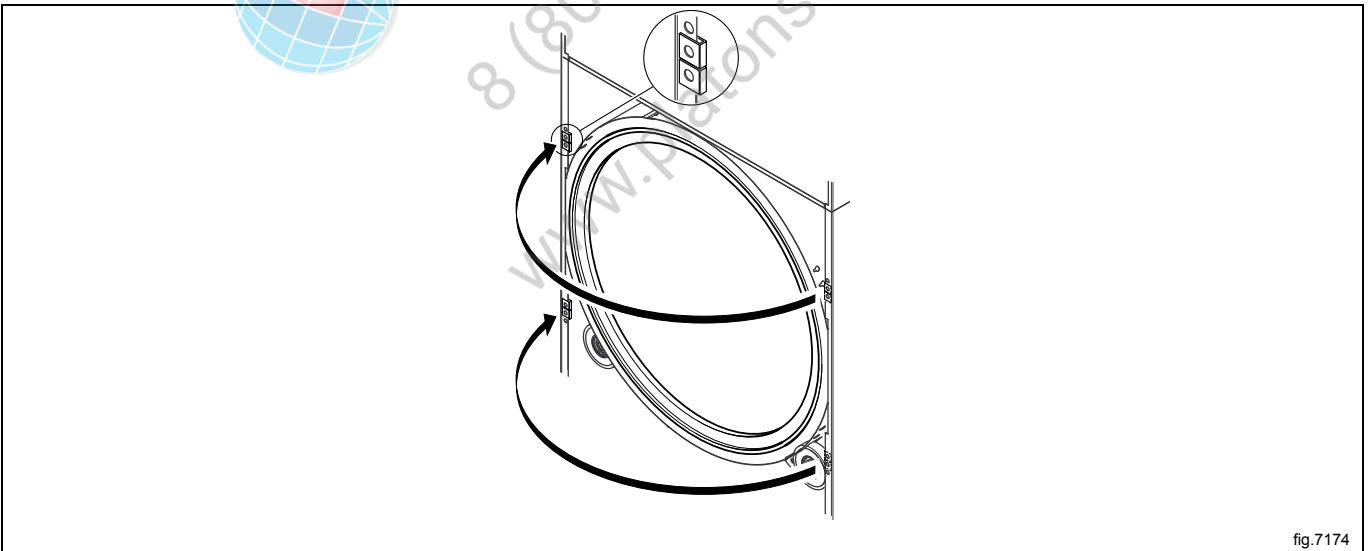
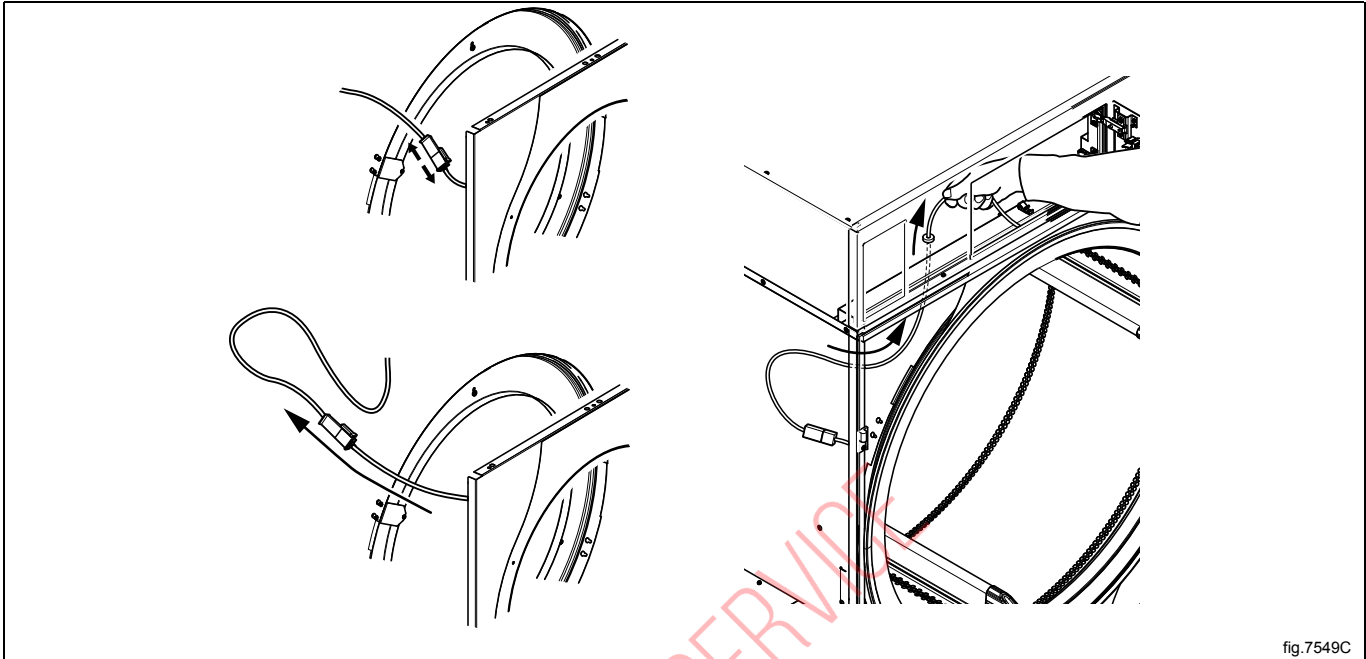

fig.7174

Connect the door switch cable and push the cable in over the drum and pull it upwards.



Remount the front panel.



Ensure that the door switch cable does not get damaged when remounting the front panel.



Fasten the hinges and mount the door on the opposite side.

Connect the power to the machine.

Test run the machine.



PLATON SERVICE
8 (800) 500-34-47
www.platonservice.com

7 Motor

7.1 Replacement of motor

Disconnect the power to the machine.

Demount the rear panel.

Disconnect the motor cable (A).

Loosen the belt tensioner (B).

Loosen both of the belts (C).

Demount the motor module.

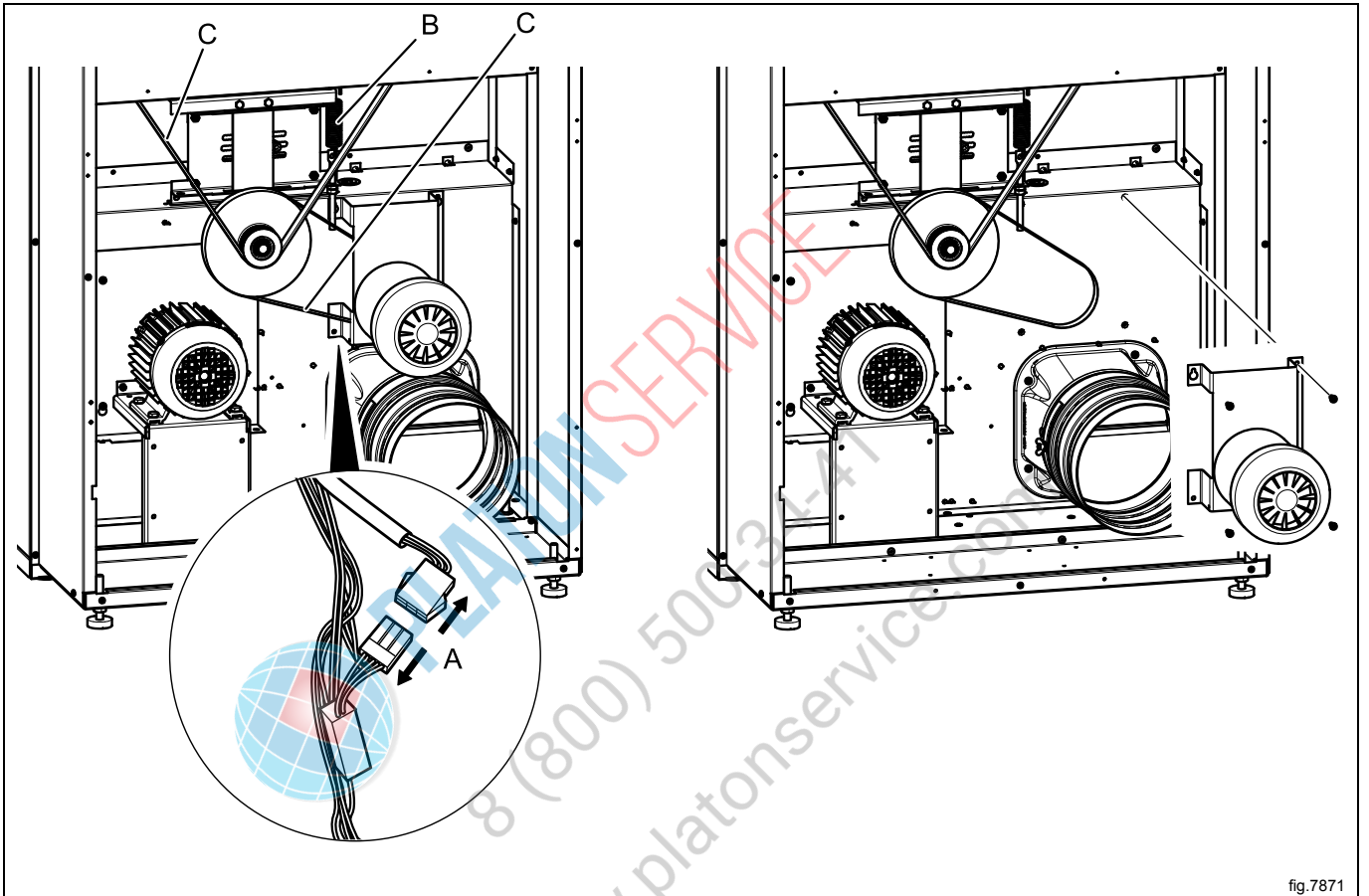

fig.7871

Demount the motor from the bracket.

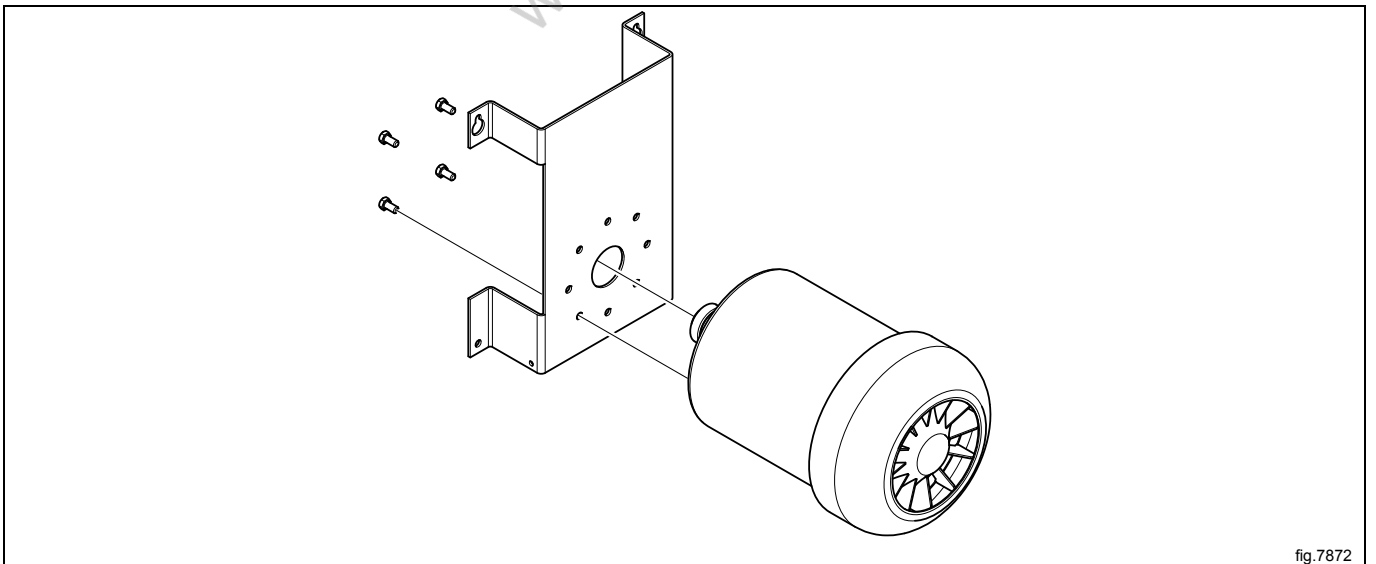

fig.7872

Before mounting the new motor it is important to lubricate the motor shaft with an anti-fretting paste (Antifret LAGF 3 / 0.6 or similar quality).

Mount the new motor on the bracket. Tighten the screws (D) with tightening torque 3 Nm. Remount the motor module in the machine.

Fasten the belts and make sure the belts are in position. Fasten the belt tensioner and connect the motor cable.

Remount the rear panel.

7.2 Replacement of fan motor

On machines with reversing

Disconnect the power to the machine.

Demount the rear panel.

Disconnect the motor cable.

Demount the fan module.

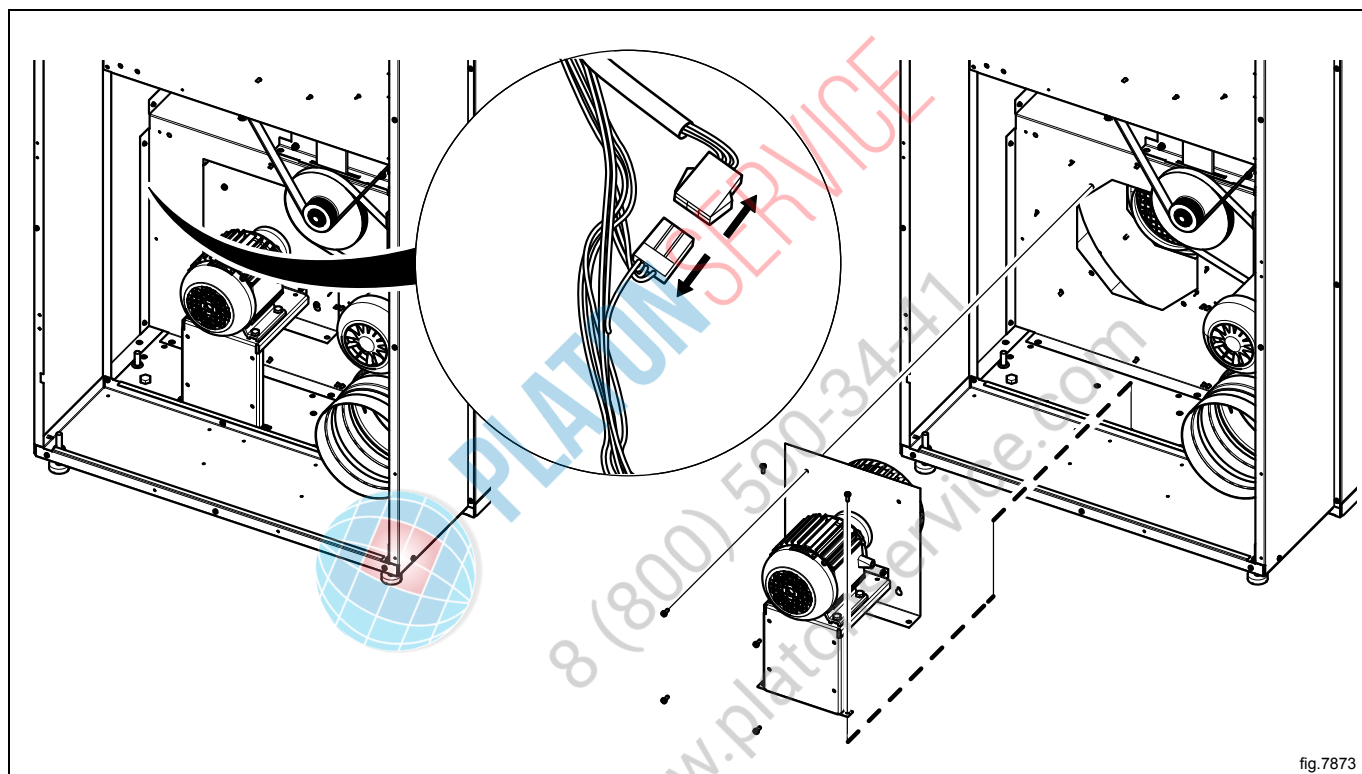

fig.7873

Demount the screw and pull off the fan wheel.

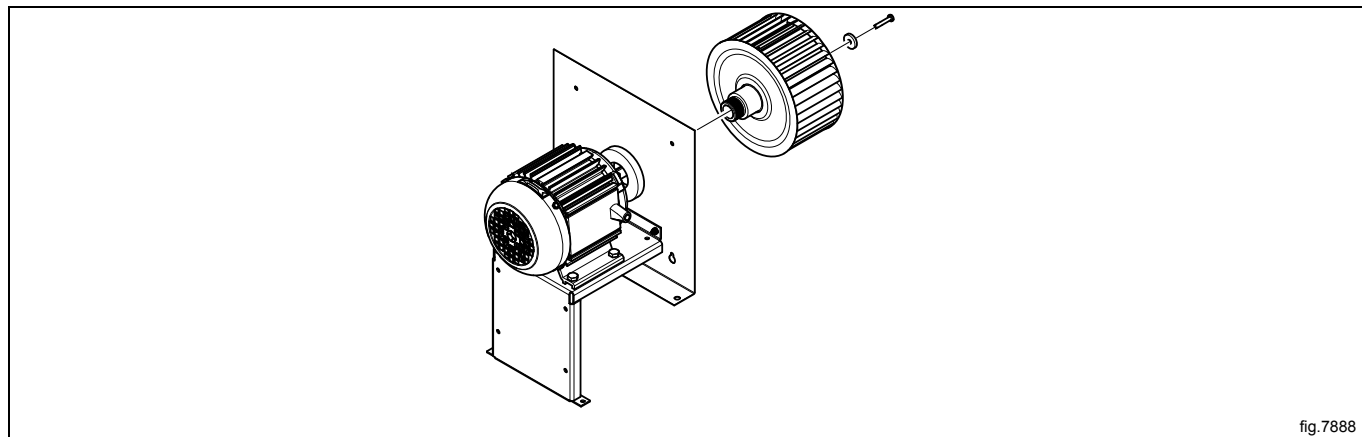
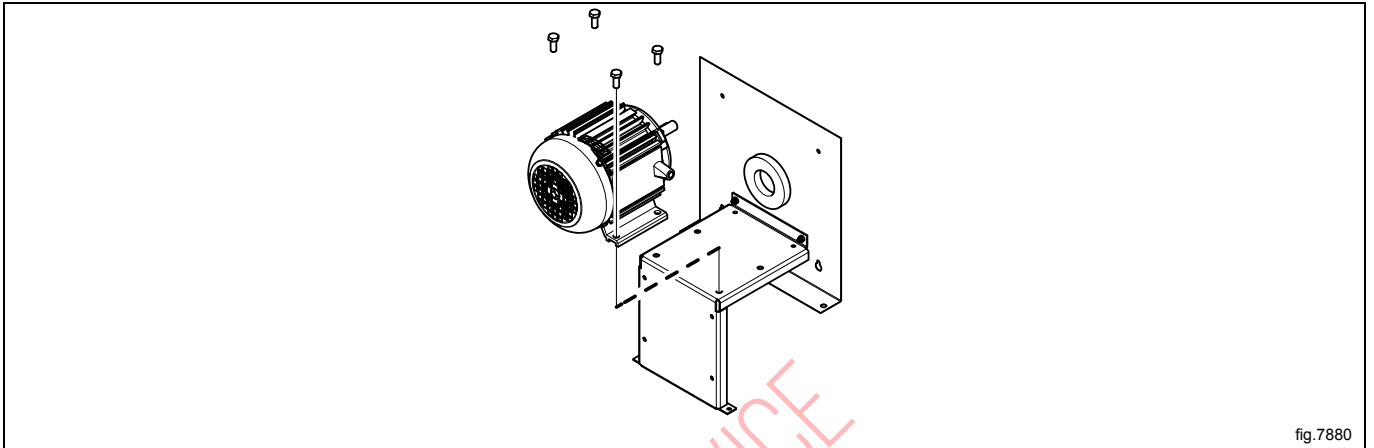

fig.7888

Demount the fan motor.

Before mounting the new motor it is important to lubricate the motor shaft with an anti-fretting paste (Antifret LAGF 3 / 0.6 or similar quality).

Mount the new fan motor. Thighten the screws with tightening torque 20 Nm.



Remount the fan wheel on the fan motor. Lubricate the screw using a protection product such as Omnifit Seal 40M or similar and tighten the screw with tightening torque 5 Nm.

Remount the fan module in the machine.

Connect the motor cable.

Remount the rear panel.

On machines without reversing

Disconnect the power to the machine.

Demount the rear panel.

Disconnect the motor cable (A).

Loosen the belt tensioner (B).

Loosen both of the belts (C).

Demount the fan module.

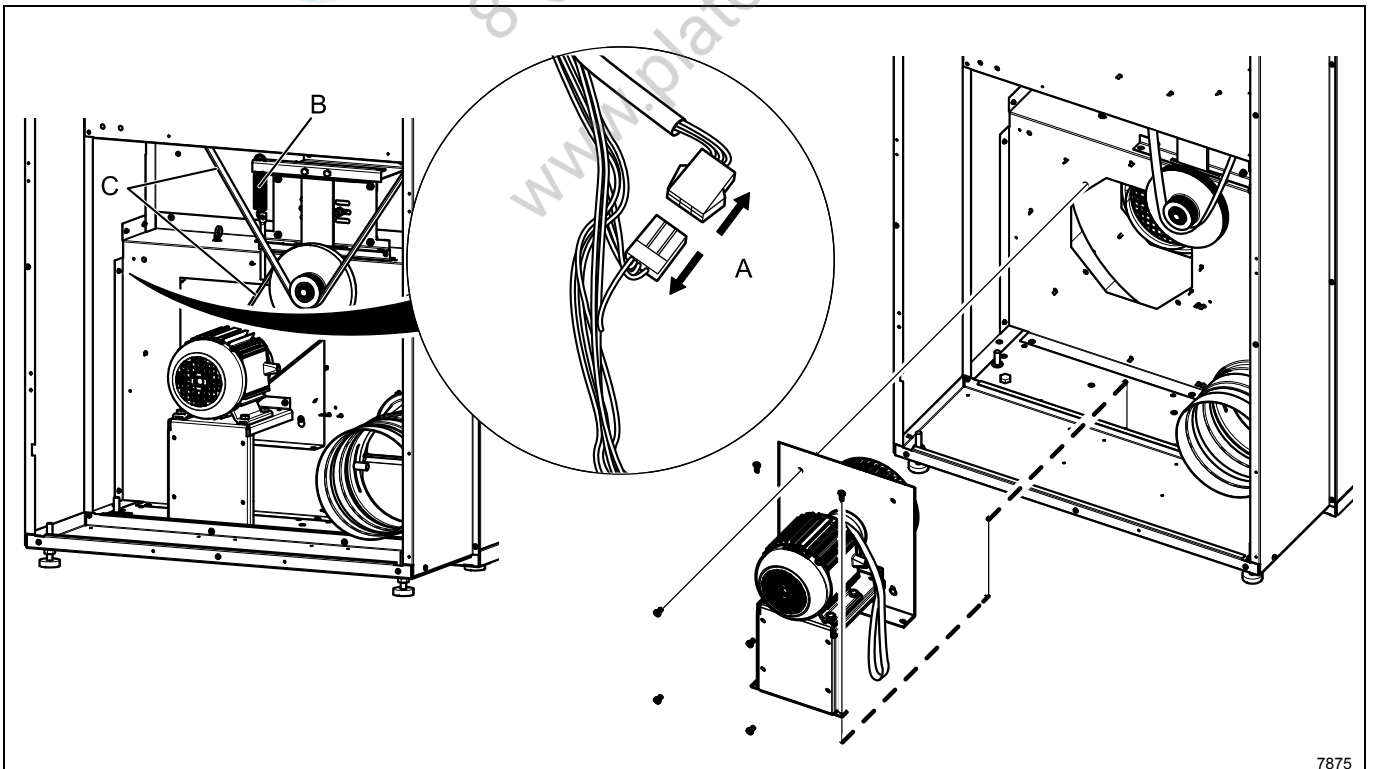

Demount the screw and pull off the fan wheel.

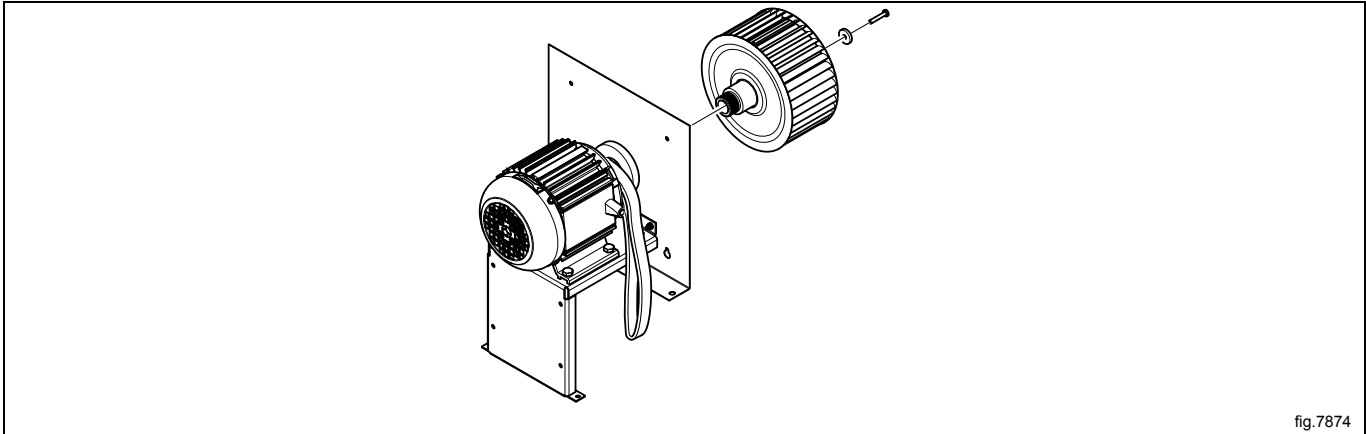

fig.7874

Demount the fan motor and remove the belt.

Before mounting the new motor it is important to lubricate the motor shaft with an anti-fretting paste (Antifret LAGF 3 / 0.6 or similar quality).

Put the belt in position and mount the new motor. Tighten the screws with tightening torque 20 Nm.

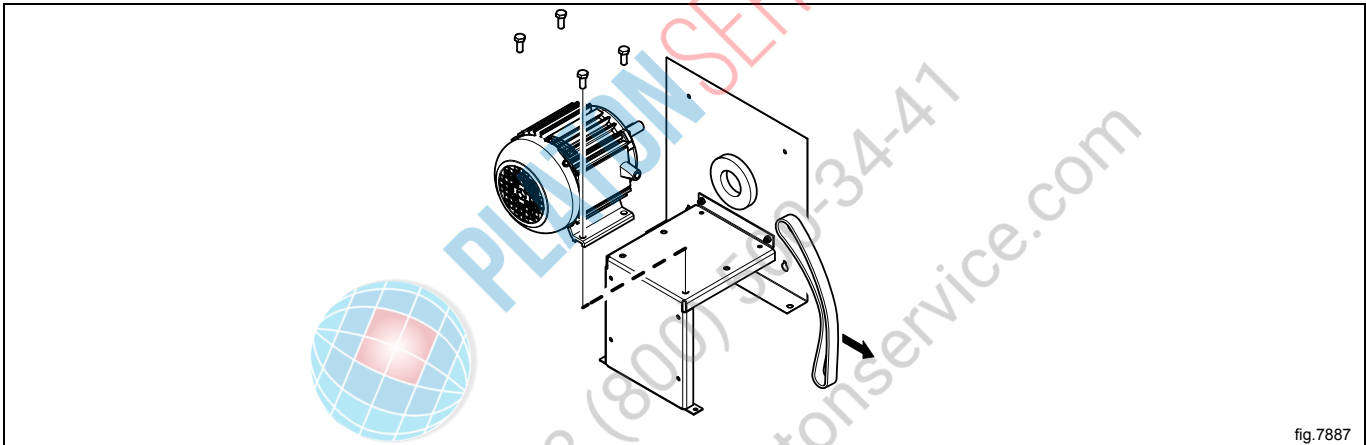

fig.7887

Remount the fan wheel on the fan motor. Lubricate the screw using a protection product such as Omnifit Seal 40M or similar and tighten the screw with tightening torque 5 Nm.

Remount the fan module in the machine.

Fasten the belts and make sure the belts are in position. Fasten the belt tensioner and connect the motor cable.

Remount the rear panel.

7.3 Replacement of fan

On machines with reversing

Disconnect the power to the machine.

Demount the rear panel.

Disconnect the motor cable.

Demount the fan module.

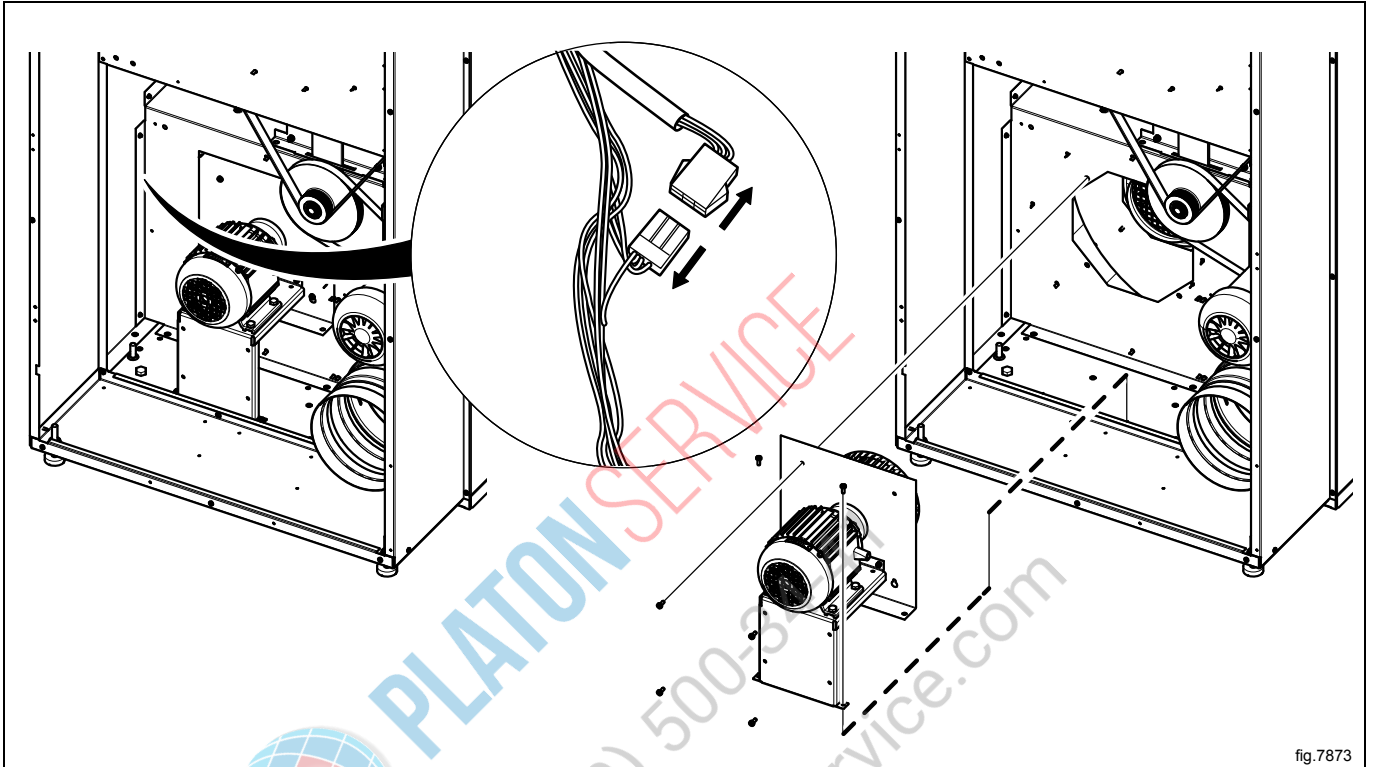

Demount the screw and pull off the fan wheel.

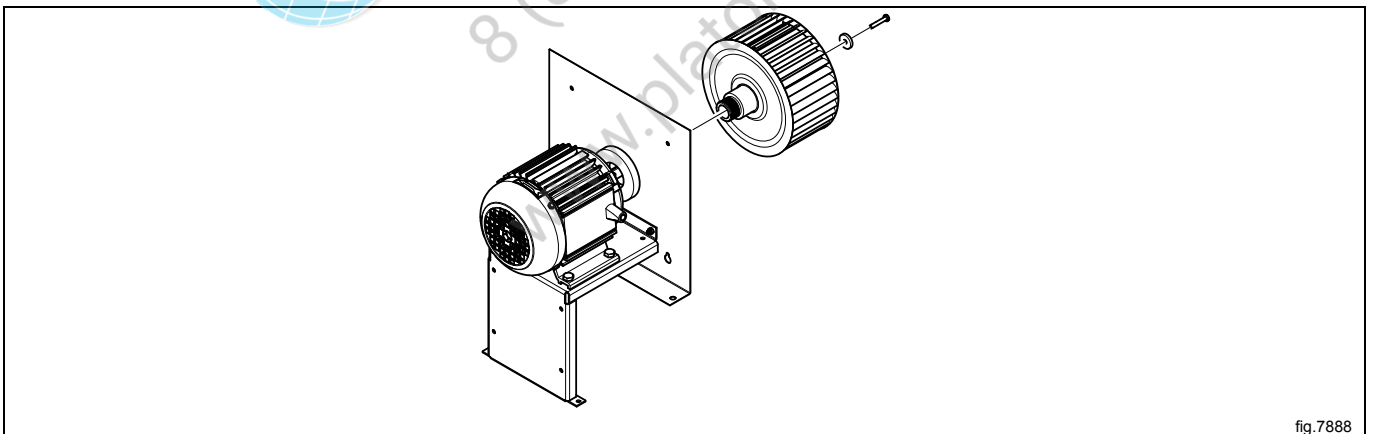

Mount the new fan wheel on the fan motor. Lubricate the screw using a protection product such as Omnifit Seal 40M or similar and tighten the screw with tightening torque 5 Nm.

Remount the fan module in the machine.

Connect the motor cable.

Remount the rear panel.

On machines without reversing

Disconnect the power to the machine.

Demount the rear panel.

Disconnect the motor cable (A).

Loosen the belt tensioner (B).

Loosen both of the belts (C).

Demount the fan module.

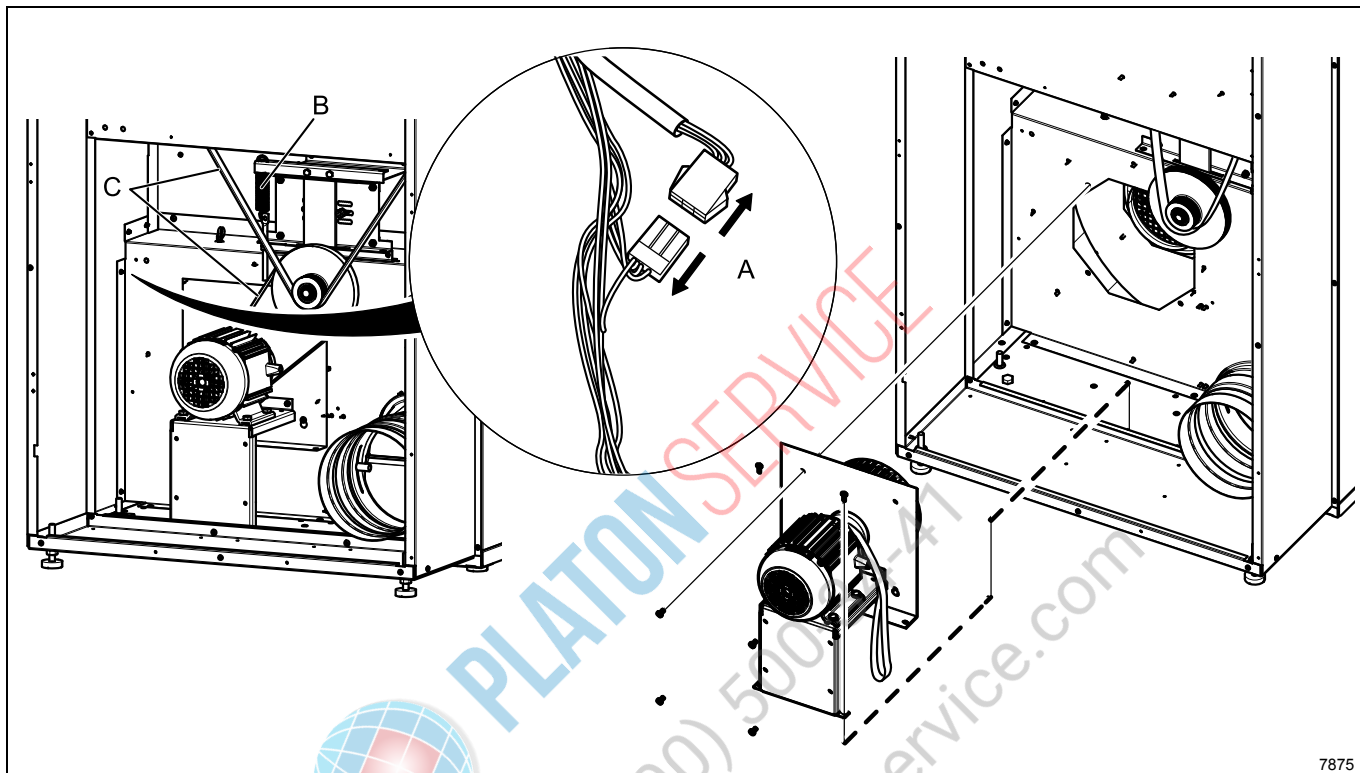

7875

Demount the screw and pull off the fan wheel.

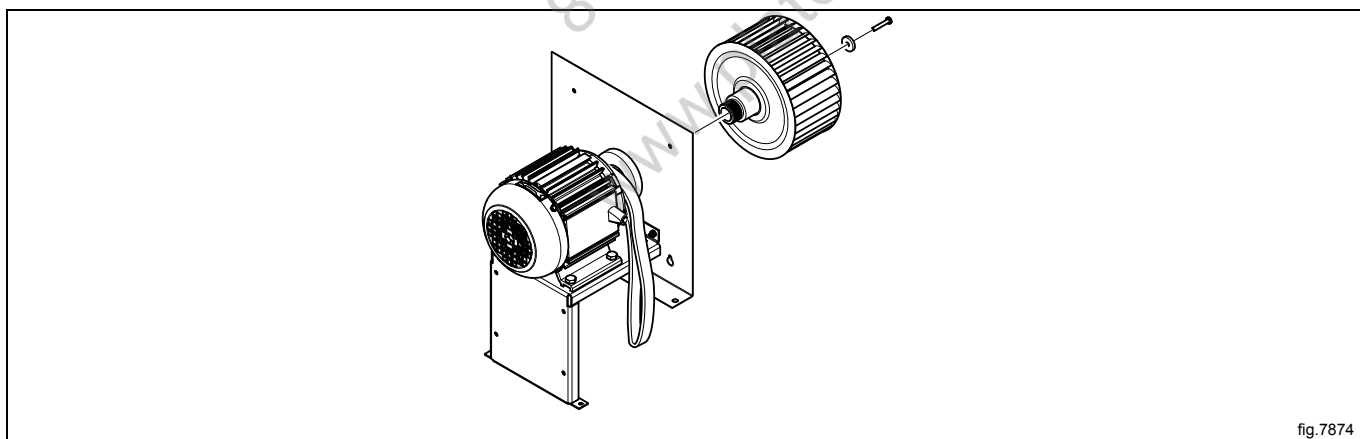

fig.7874

Mount the new fan wheel on the fan motor. Lubricate the screw using a protection product such as Omnifit Seal 40M or similar and tighten the screw with tightening torque 5 Nm.

Remount the fan module in the machine.

Fasten the belts and make sure the belts are in position. Fasten the belt tensioner and connect the motor cable.

Remount the rear panel.

7.4 Replacement of motor pulley

Disconnect the power to the machine.

Demount the rear panel.

Disconnect the motor cable (A).

Loosen the belt tensioner (B).

Loosen both of the belts (C).

Demount the motor module.

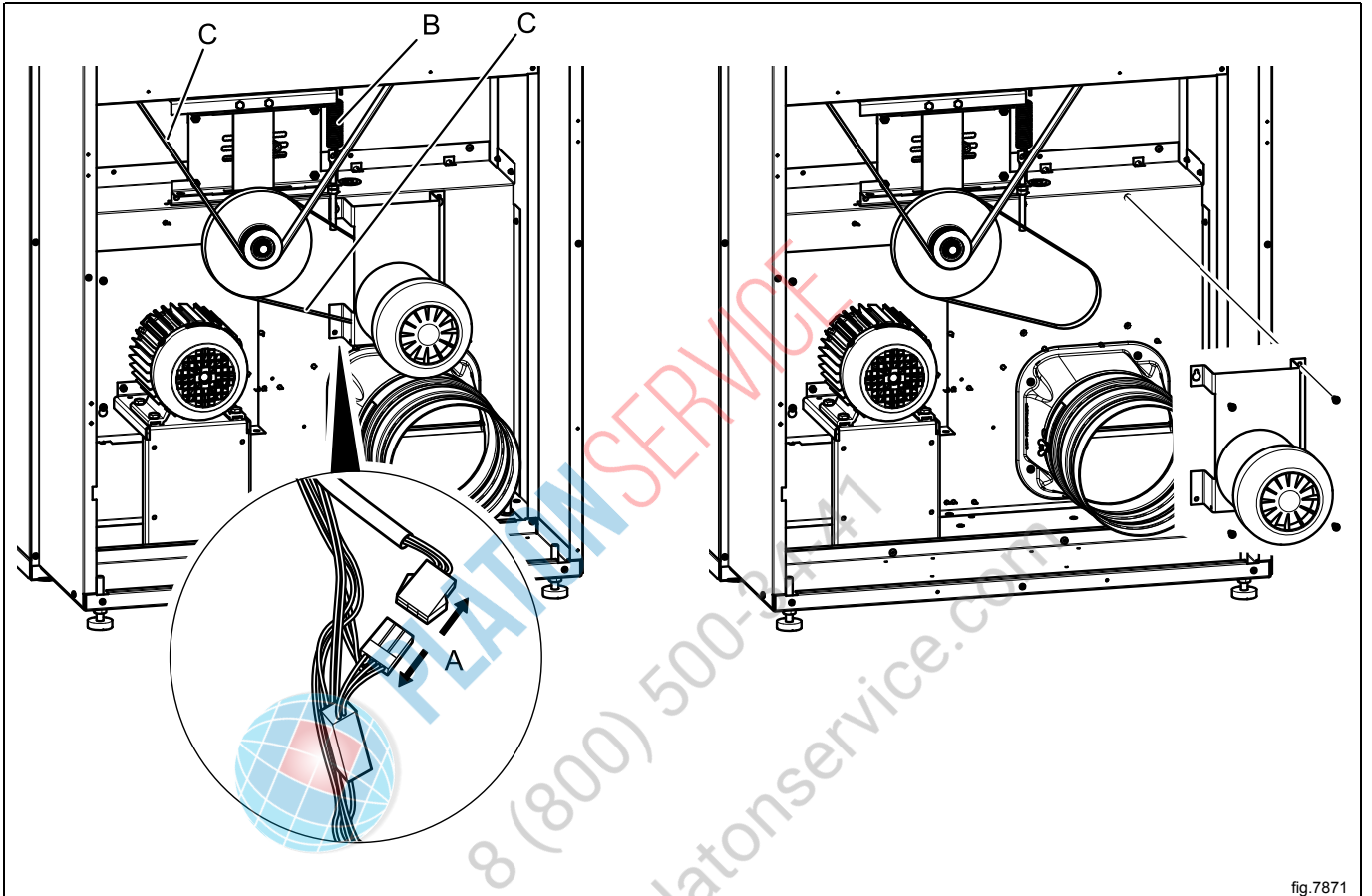
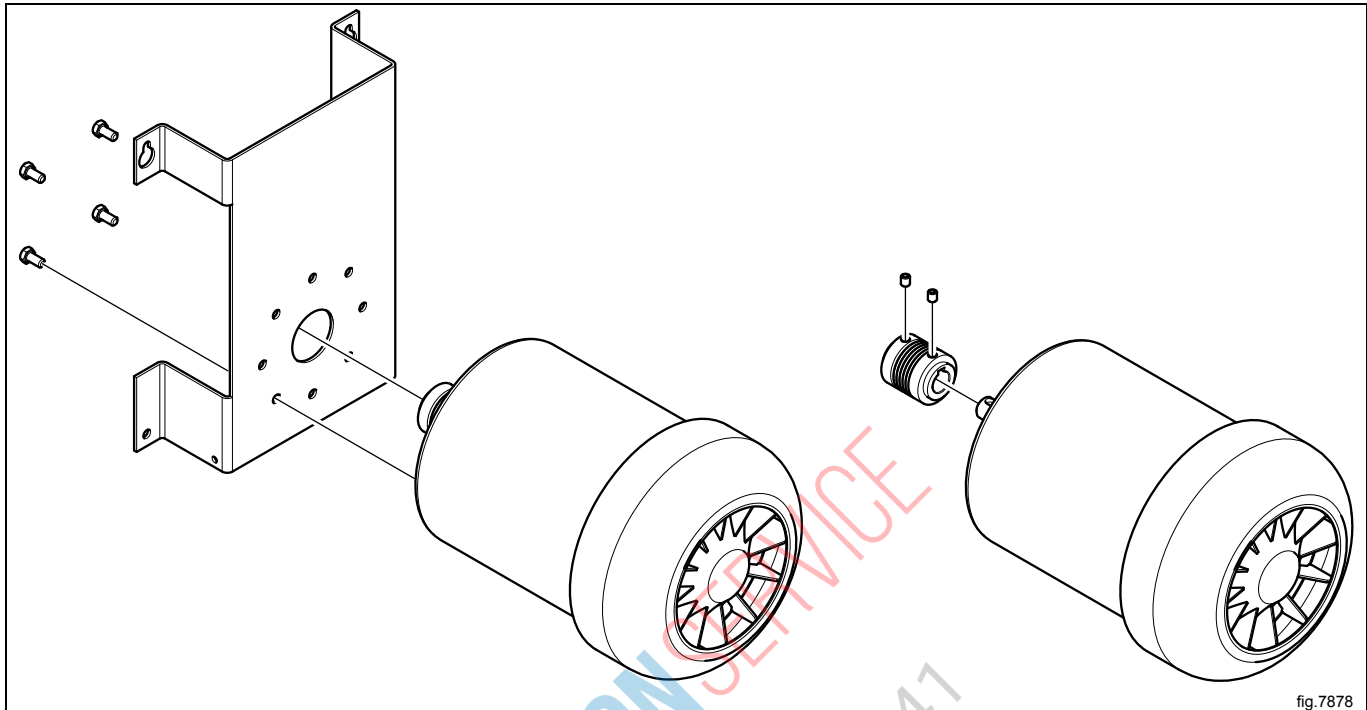

fig.7871

Demount the motor from the bracket.

Demount the two Allen screws and remove the pulley.



Before remounting the motor it is important to lubricate the motor shaft with an anti-fretting paste (Antifret LAGF 3 / 0.6 or similar quality).

Remount the motor on the bracket. Tighten the screws (D) with tightening torque 3 Nm.

Mount the new motor pulley. Lubricate the two Allen screws with a screw protection product such as Omnifit Seal 40M or similar. Tighten the screws with tightening torque 3Nm.

Remount the motor module in the machine.

Fasten the belts and make sure the belts are in position. Fasten the belt tensioner and connect the motor cable.

Remount the rear panel.

7.5 Replacement of the belt around the motor pulley

On machines with reversing

Disconnect the power to the machine.

Demount the rear panel.

Disconnect the motor cable (A).

Loosen the belt tensioner (B).

Loosen both of the belts (C).

Demount the motor module.

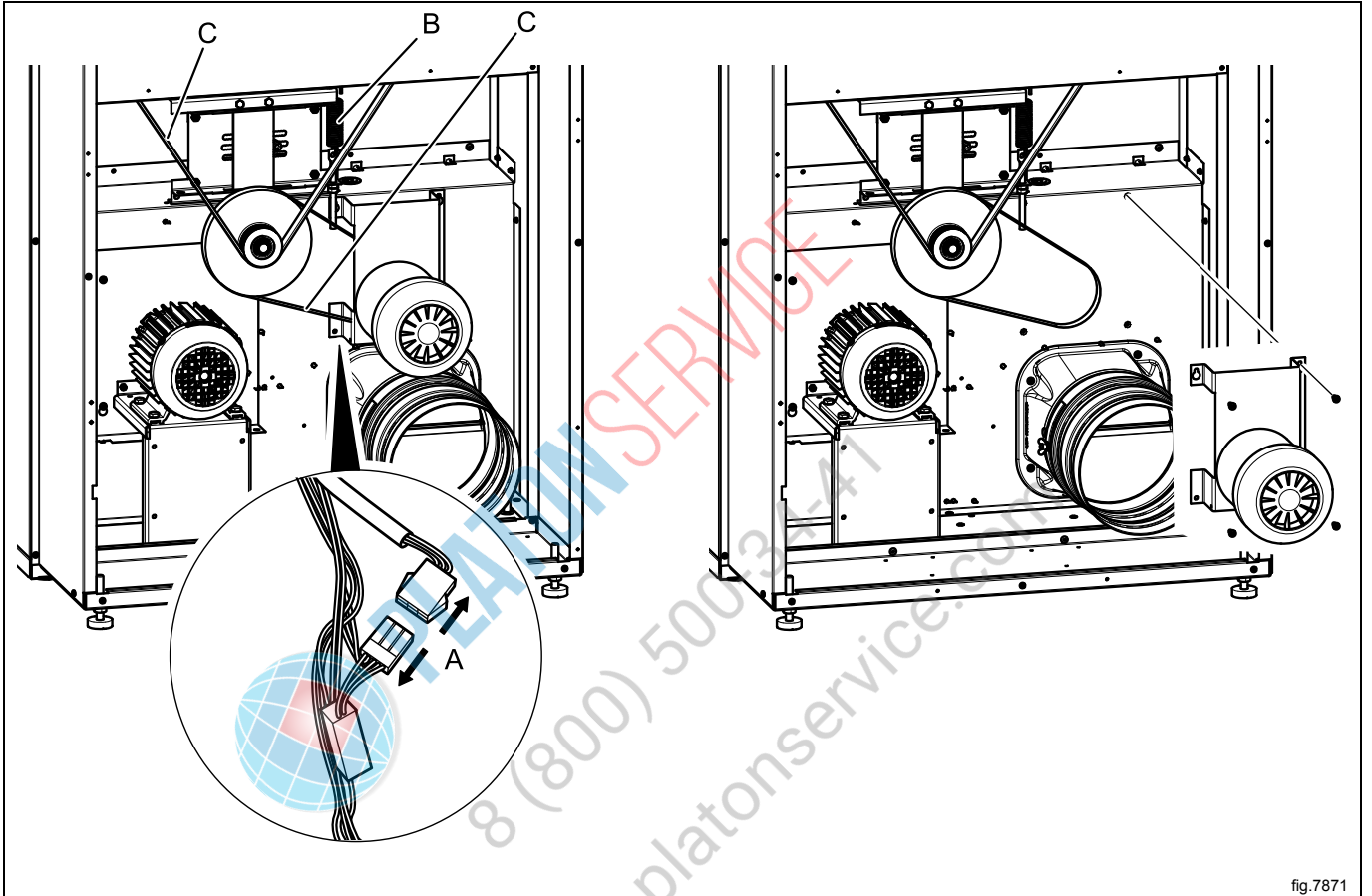

fig.7871

Remove the belt and put the new belt in position.

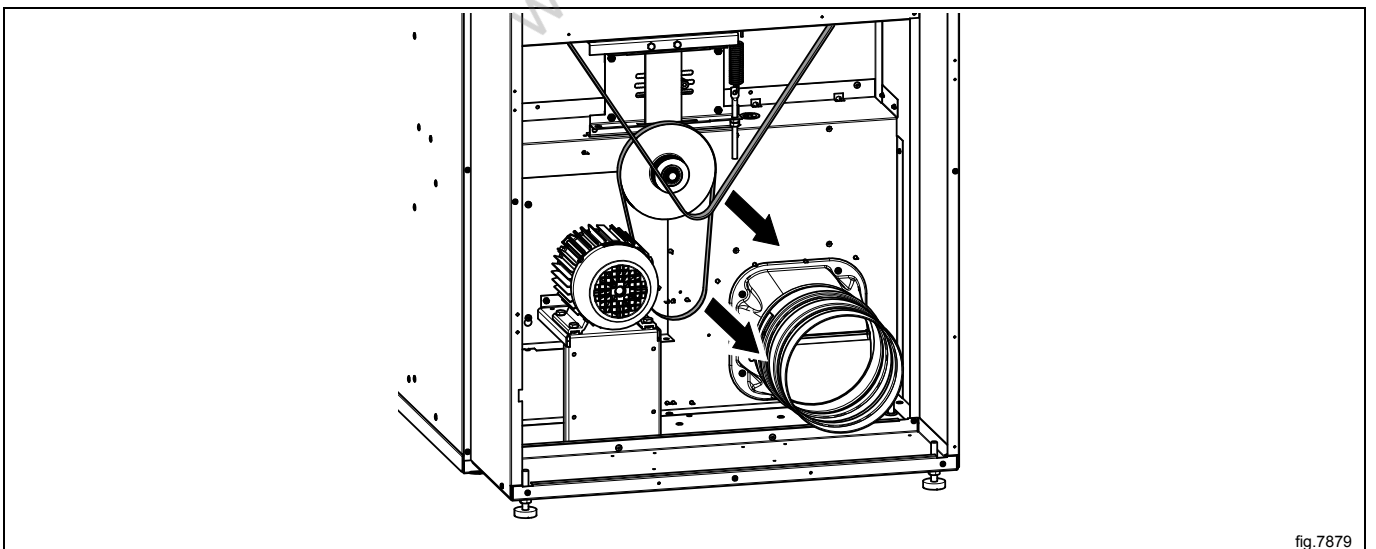

fig.7879

Remount the motor module in the machine.

Fasten the belts and make sure the belts are in position. Fasten the belt tensioner and connect the motor cable.

Remount the rear panel.

On machines without reversing

Disconnect the power to the machine.

Demount the rear panel.

Disconnect the motor cable (A).

Loosen the belt tensioner (B).

Loosen both of the belts (C).

Demount the fan module.

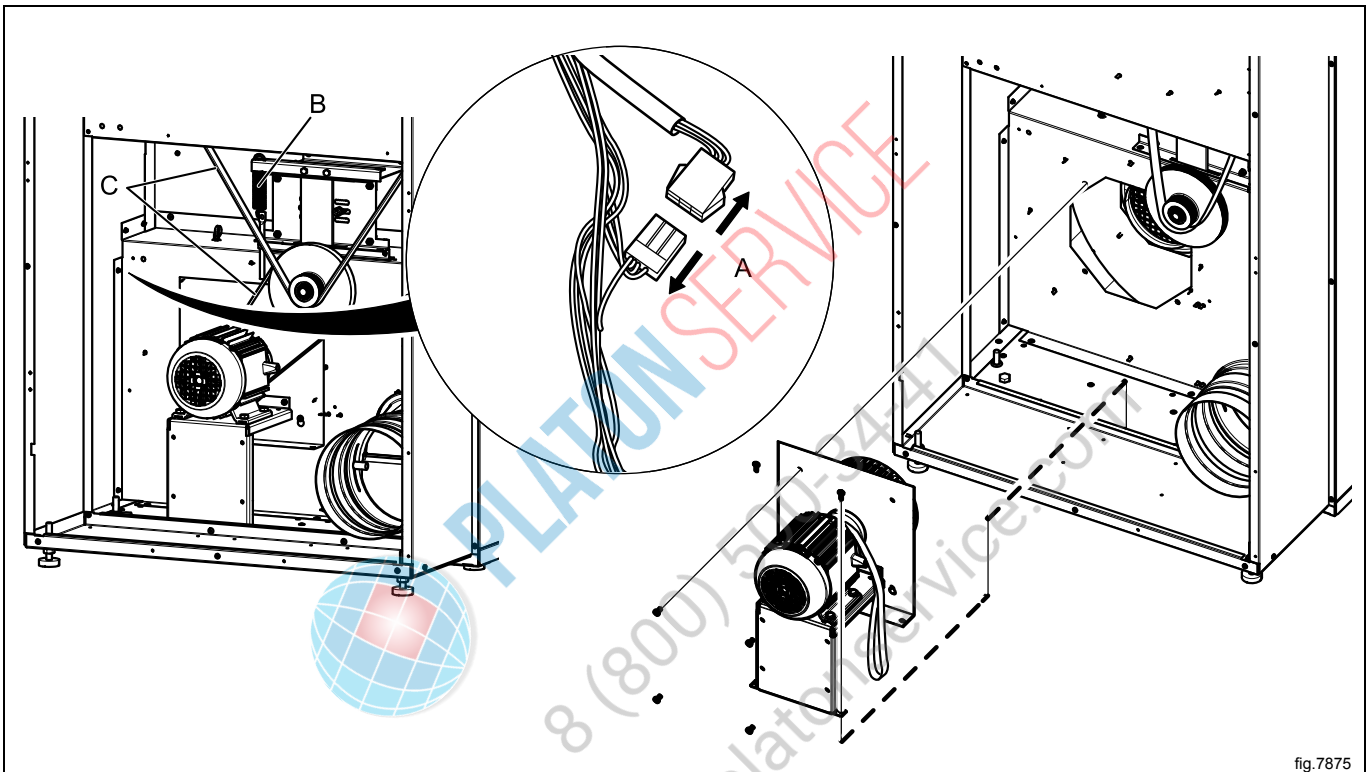

fig.7875

Demount the screw and pull off the fan wheel.

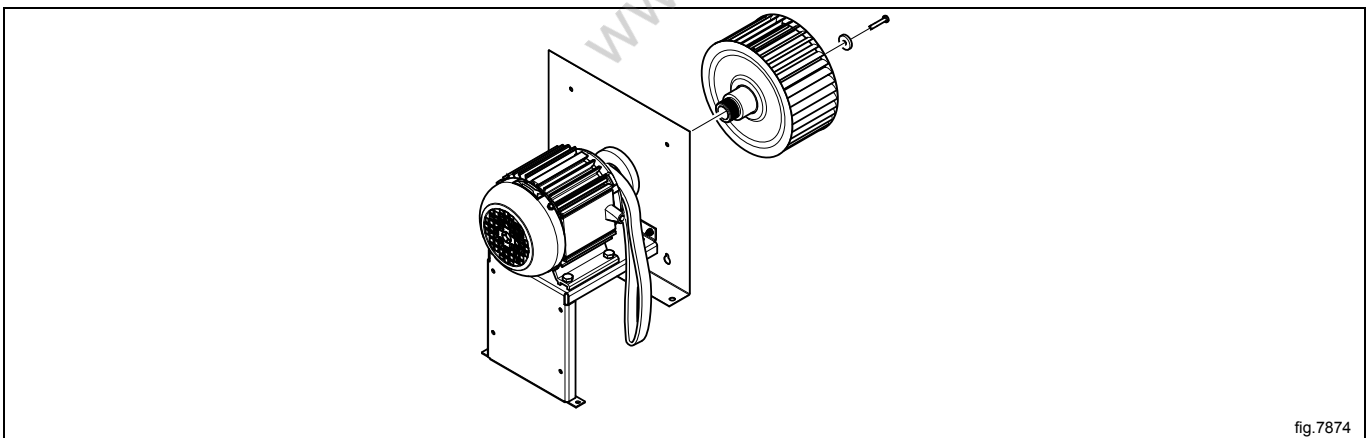
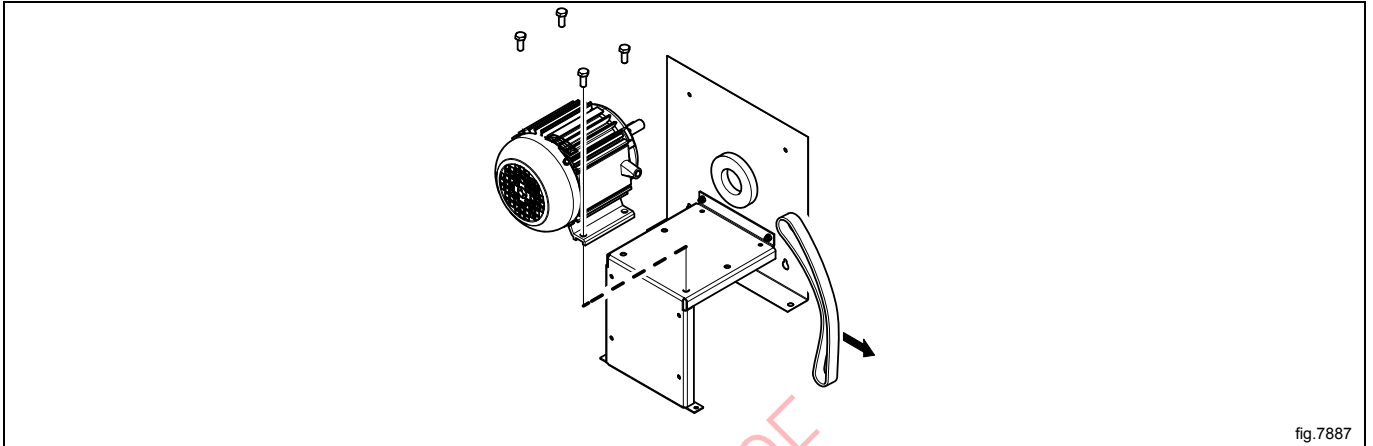

fig.7874

Demount the fan motor and remove the belt. Put the new belt in position and remount the motor.

Before remounting the motor it is important to lubricate the motor shaft with an anti-fretting paste (Antifret LAGF 3 / 0.6 or similar quality). Tighten the screws with tightening torque 20 Nm.



Remount the fan wheel on the fan motor. Lubricate the screw using a protection product such as Omnifit Seal 40M or similar and tighten the screw with tightening torque 5 Nm.

Remount the fan module in the machine.

Fasten the belts and make sure the belts are in position. Fasten the belt tensioner and connect the motor cable.

Remount the rear panel.



PLATON SERVICE
8 (800) 500-34-41
www.platonservice.com

7.6 Replacement of pulley

On machines with reversing

Disconnect the power to the machine.

Demount the rear panel.

Loosen the belt tensioner (B).

Loosen both of the belts (C).

Remove the split pin and the three spring washers (D). Pull off the pulley and mount the new pulley.

Remount the three spring washers and the split pin.

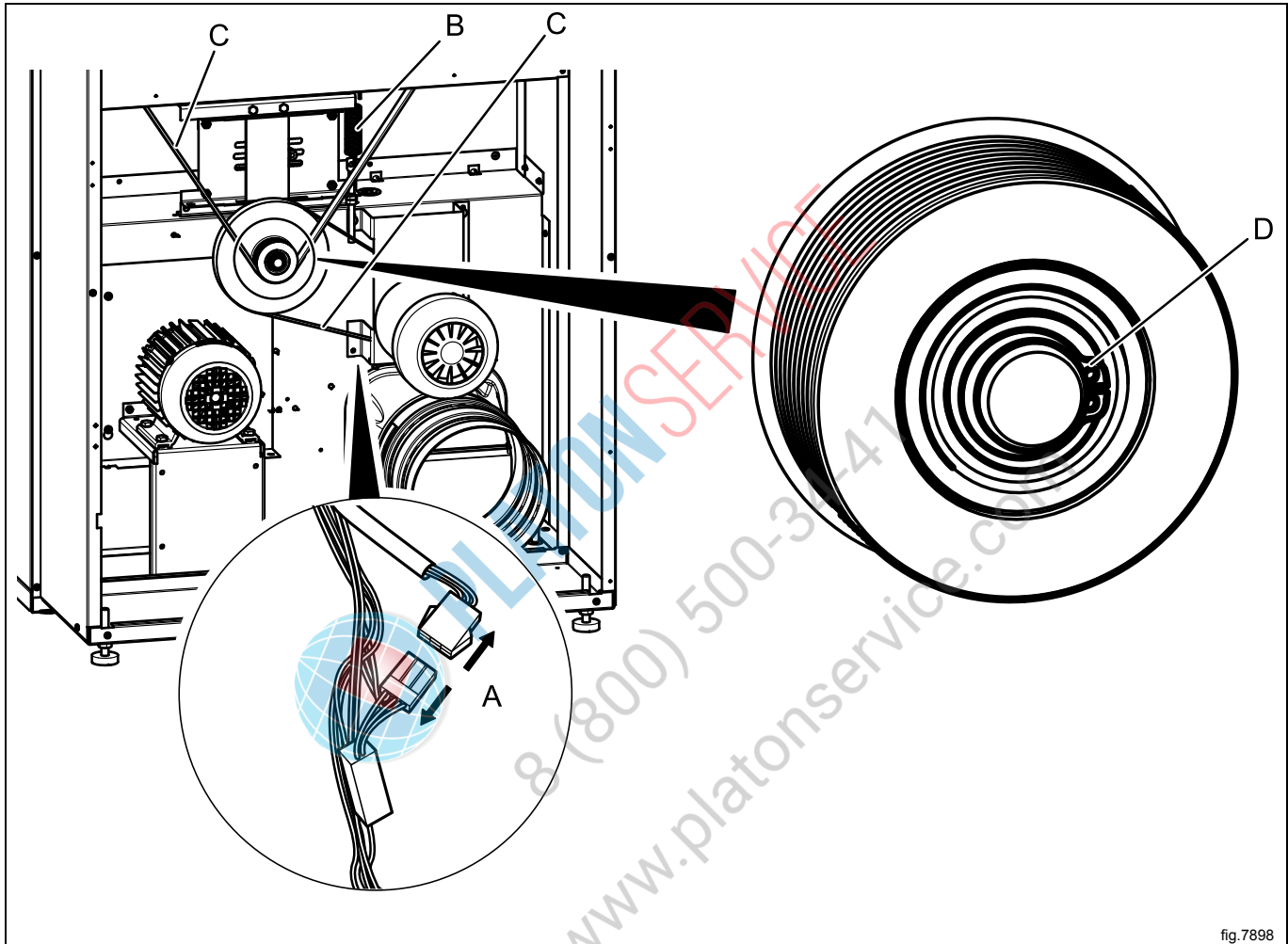

fig.7898

Fasten the belts and make sure the belts are in position. Mount the belt tensioner.

Remount the rear panel.

On machines without reversing

Disconnect the power to the machine.

Demount the rear panel.

Loosen the belt tensioner (B).

Loosen both of the belts (C).

Remove the split pin and the three spring washers (D). Pull off the pulley and mount the new pulley.

Remount the three spring washers and the split pin.

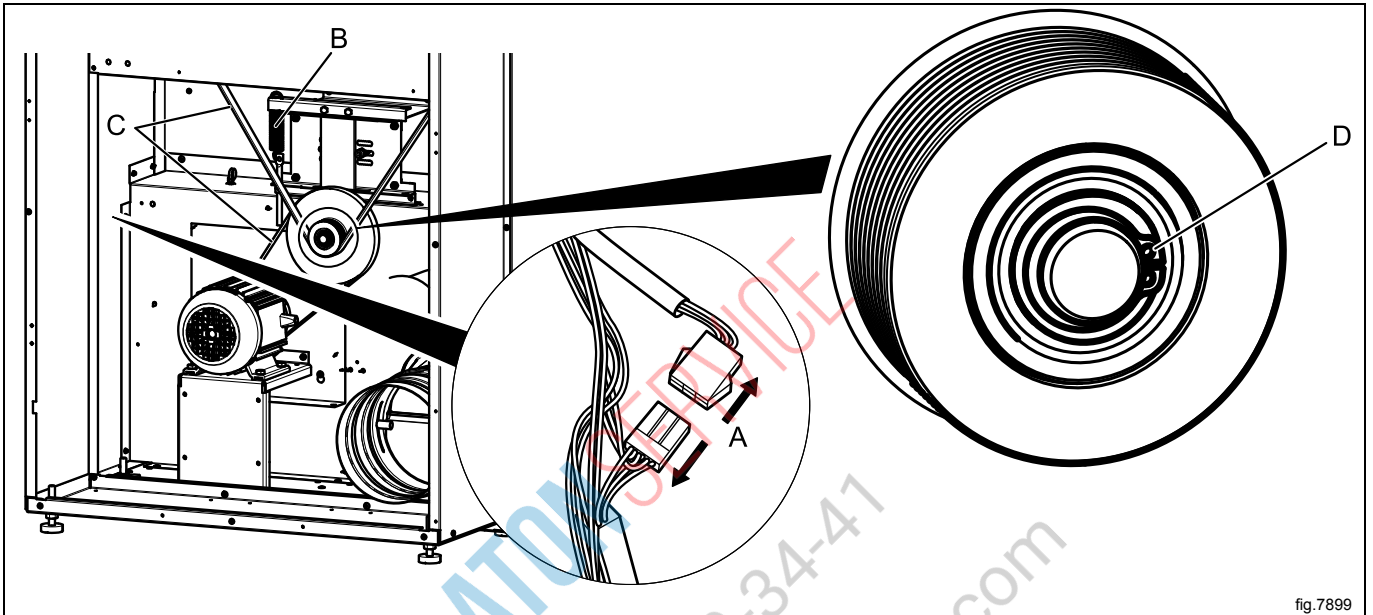

fig.7899

Fasten the belts and make sure the belts are in position. Mount the belt tensioner.

Remount the rear panel.



8 Heating unit, electric

8.1 General

Spare part number, effect and voltage are printed on each heating element.

8.2 Replacement of heating element

Disconnect the power to the machine.

Demount the rear panel.

Demount the back panel to the heating module.

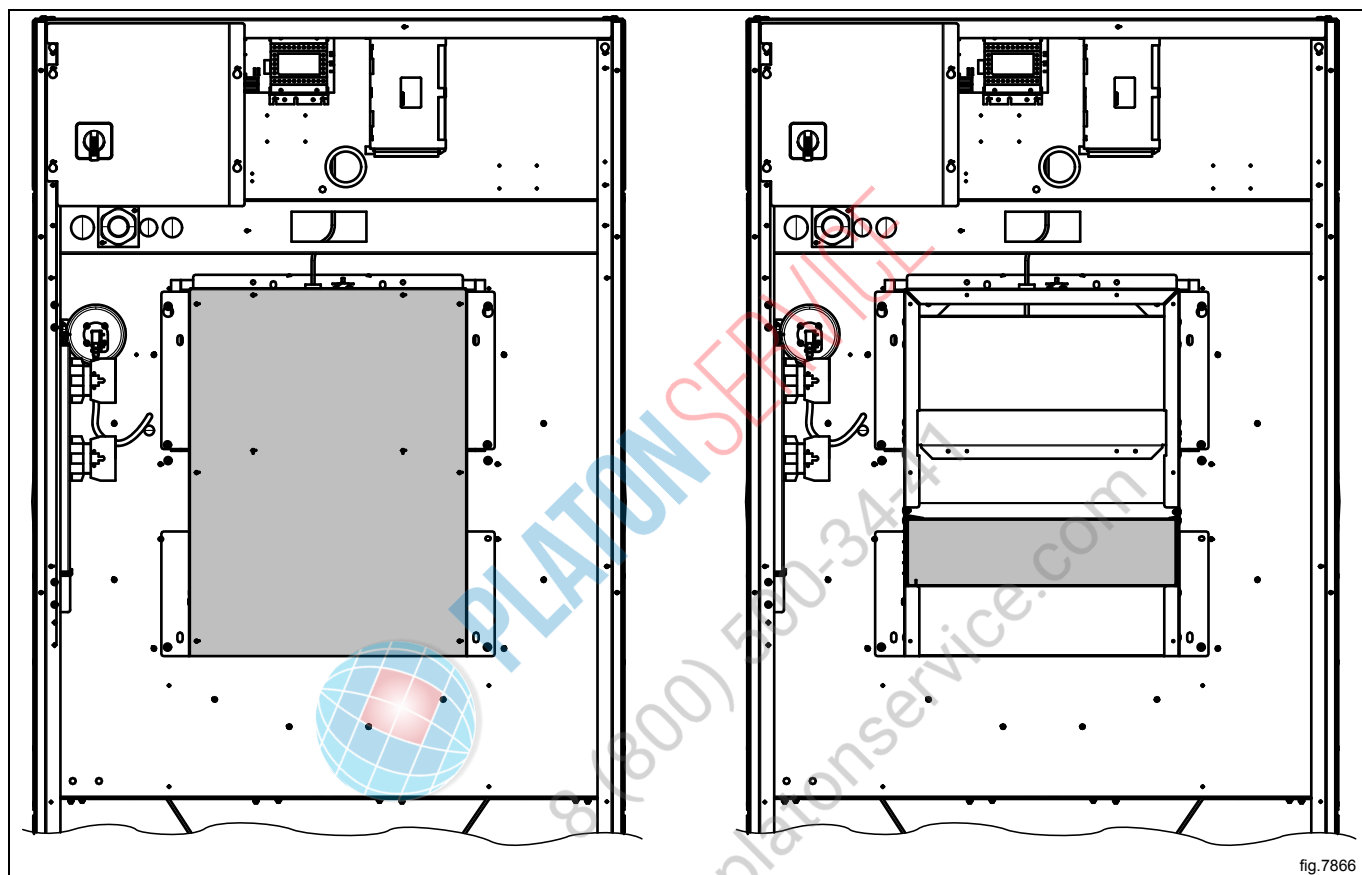

fig.7866

Hold the heating unit in position while unscrewing the screws to the “locking panels” below the heating elements.
Disconnect the wires and remove the heating element.

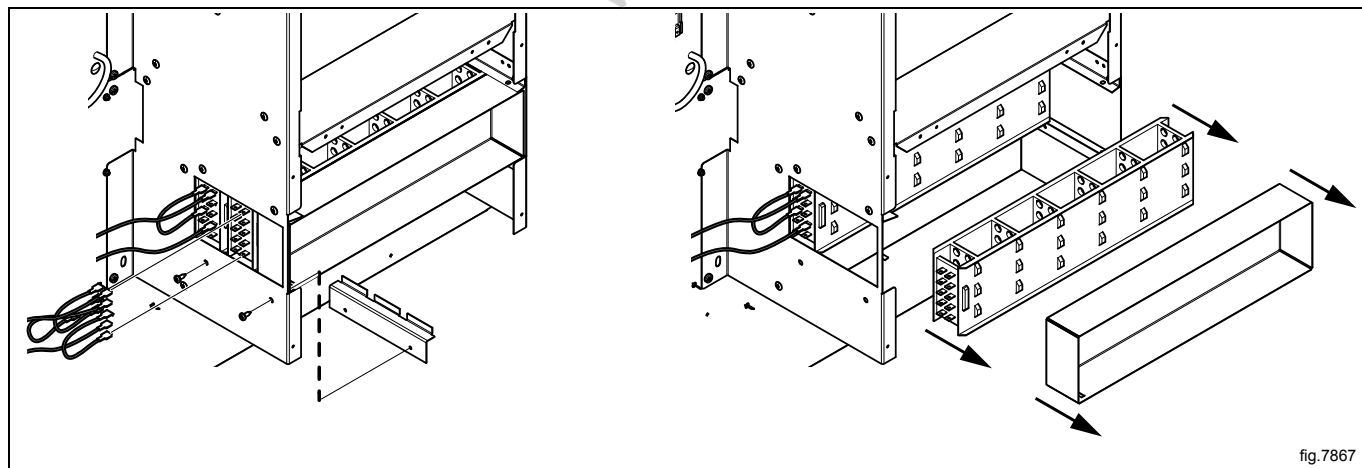

fig.7867

Connect the new element. Reconnect the wires as before, use the electric schematic supplied with the machine. Remount the “locking panels” below the heating elements.

Note!

The “locking panels” must be mounted in the same position as before. Incorrect mounting can cause the heating elements to short-circuit.



PLATON SERVICE

8 (800) 500-34-47

www.platonservice.com

9 Heating unit, gas

9.1 Replacement of gas burner

Shut off the manual gas valve.

Disconnect the power to the machine.

Demount the rear panel.

Demount the panel to the gas unit.

Demount the "locking panel" (A) from the gas unit and loosen the gas valve (B) from the gas burner.

Loosen the screw and nut (C) holding the gas burner to remove the gas burner.

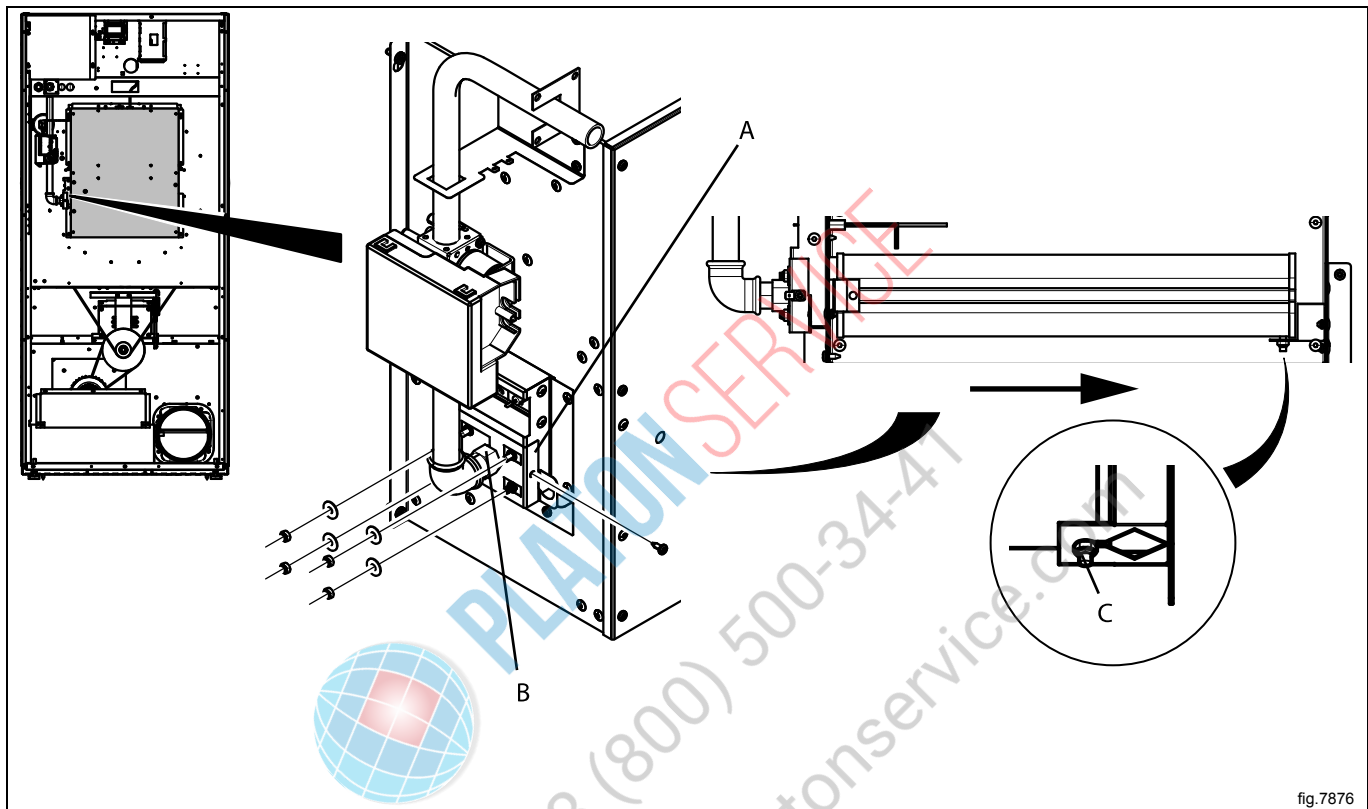

fig.7876

Mount the new gas burner with the nut and screw from the old one.

Remount the "locking panel" to the gas unit. Fasten the gas burner to the gas valve.

Remount the panel to the gas unit.

Remount the rear panel and connect the gas inlet.

9.2 Replacement of control box

Shut off the manual gas valve.

Disconnect the power to the machine.

Demount the rear panel.

Unscrew the screw to the control box.

Disconnect the wires from the control box.

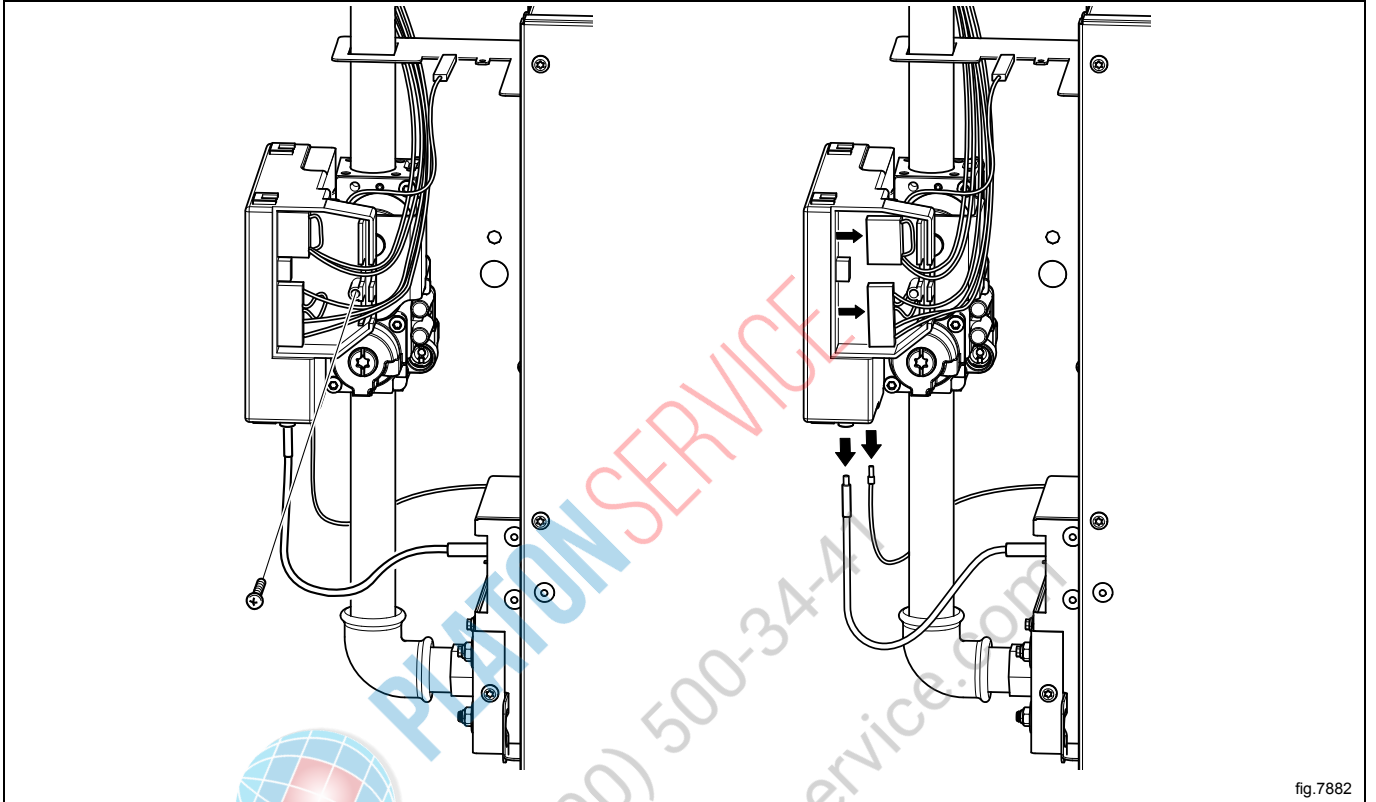

fig.7882

Remove the control box and mount the new one.

Connect the wires to the control box.

Fasten the screw to the control box and connect the ground cable.

Remount the rear panel.

9.3 Replacement of gas valve

Shut off the manual gas valve and disconnect the gas inlet.

Disconnect the power to the machine.

Demount the rear panel.

Unscrew the screws to the bracket (A) holding the gas valve.

Disconnect the heating sensor (PT100) and the overheat protection (B).

Unscrew the screw to the control box (C).

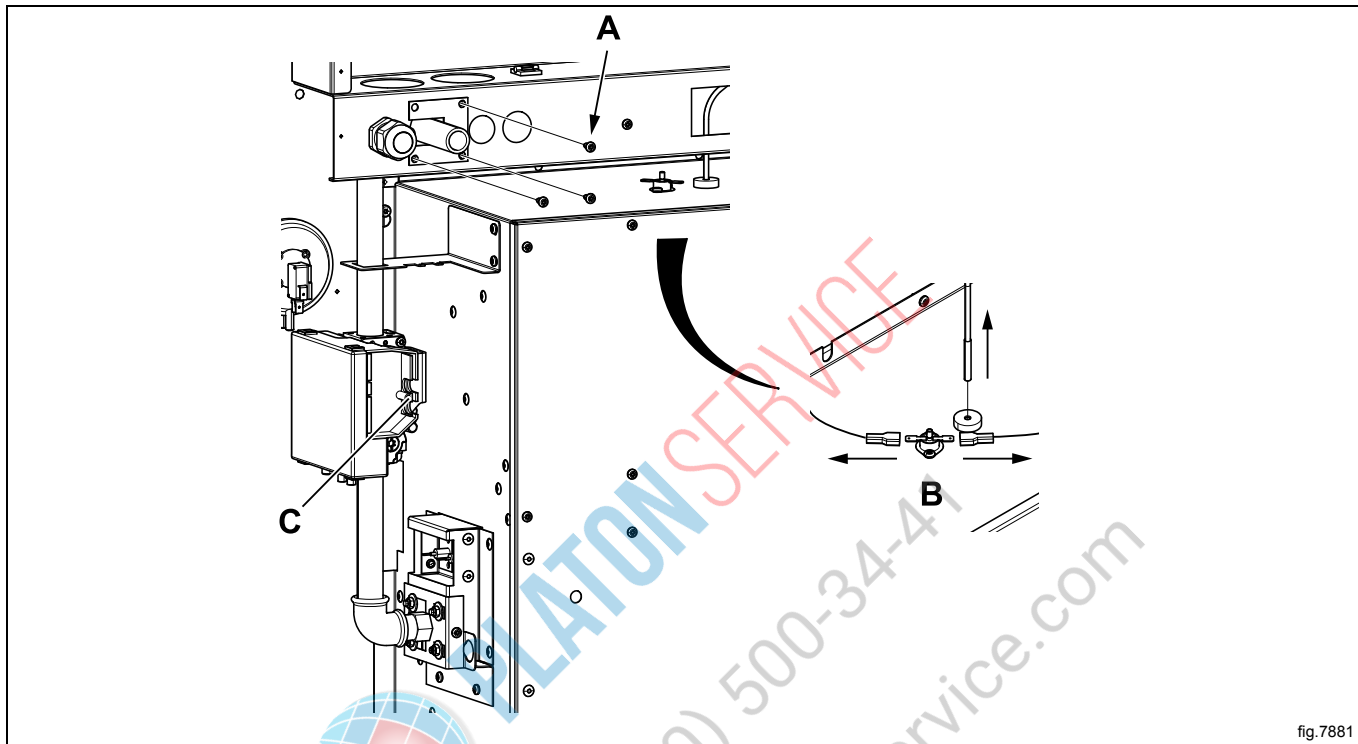

fig.7881

Disconnect the ground cable (D).

Disconnect the flame sensor and the ignition cable from the control box (E).

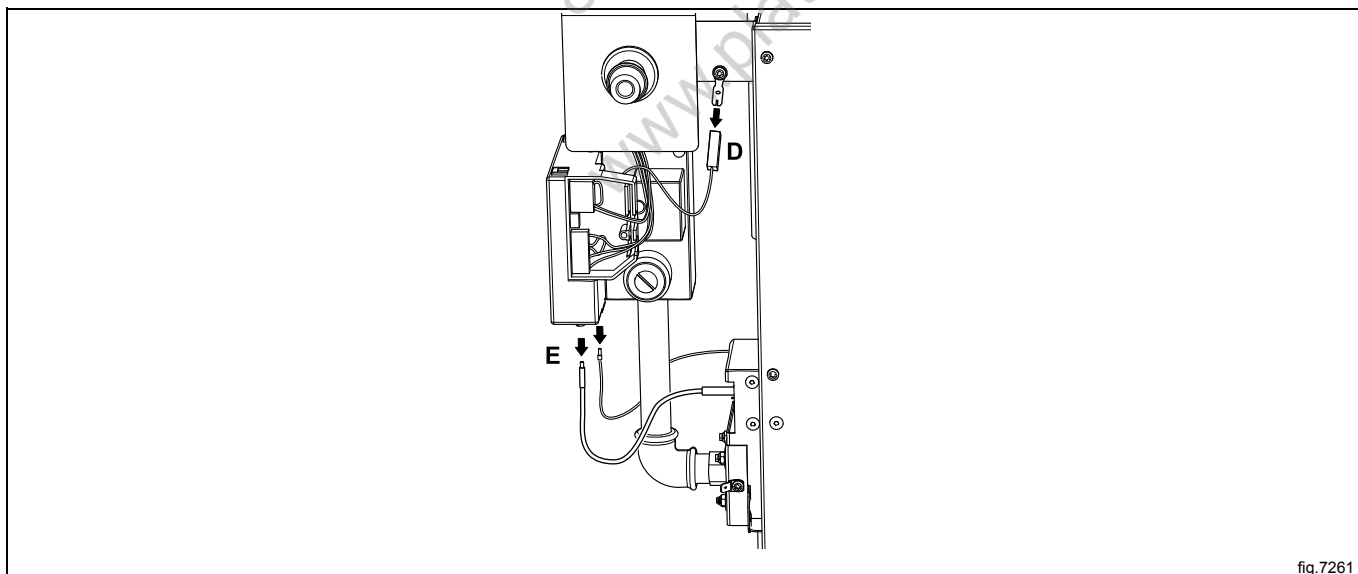
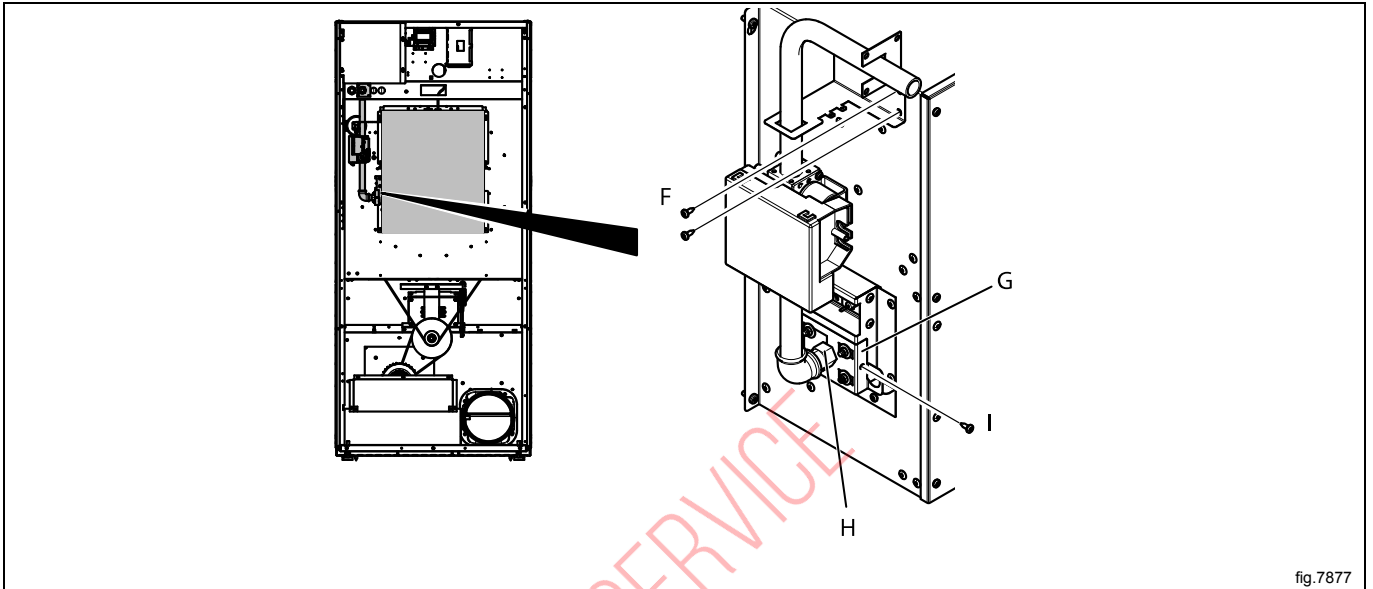

fig.7261

Demount the gas unit and carefully lift out the gas unit.

Unscrew the two screws to the bracket (F).

Unscrew the screw (I) and pull out the "locking panel" (G) to loosen the gas valve (H) from the gas burner.



Remove the gas valve and mount the new on the gas unit.

Remount the gas unit in the machine.

Connect the ground cable.

Connect the flame sensor and the ignition cable on the control box.

Fasten the screw to the control box.

Connect the heating sensor (PT100) and the overheat protection.

Fasten the screws to the bracket holding the gas valve.

Remount the rear panel and connect the gas inlet.

9.4 Replacement of flame sensor

Shut off the manual gas valve.

Disconnect the power to the machine.

Demount the rear panel.

Disconnect the wire to the flame sensor.

Demount the flame sensor.

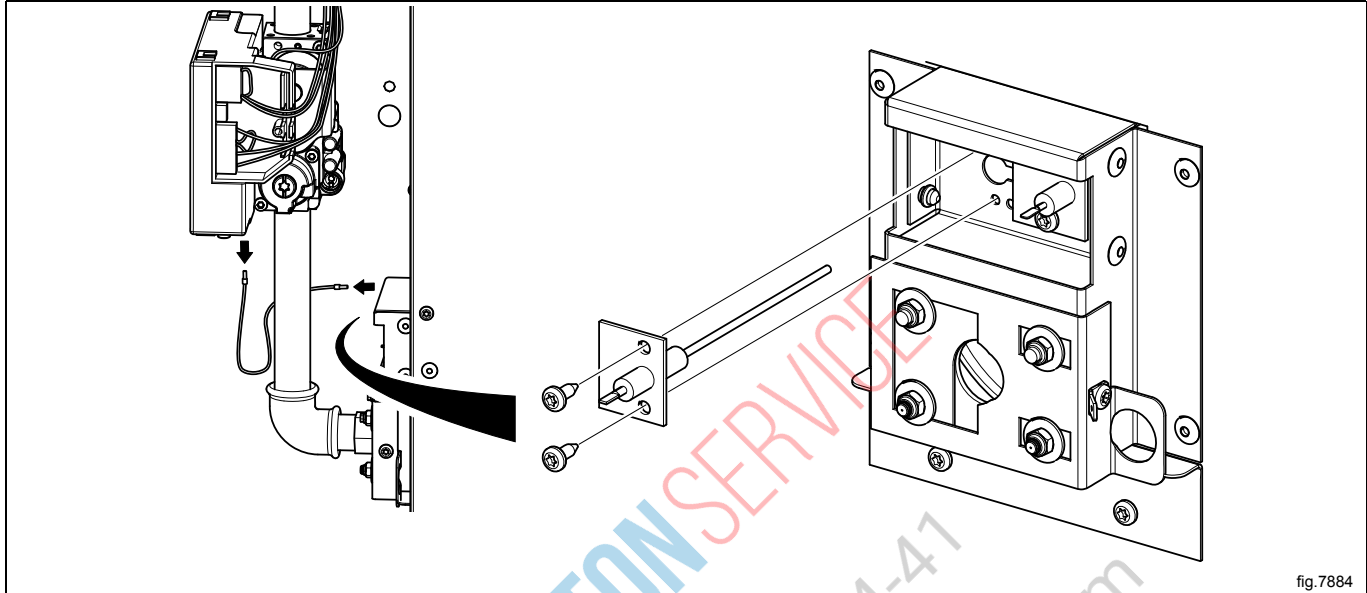

fig.7884

Mount the new flame sensor.

Control measuring the ionization current

Disconnect the wire to the flame sensor.

Measure the current between the quick connector (A) and the ionization connector (B). The current must be at least $0.9 \mu\text{A DC}$.

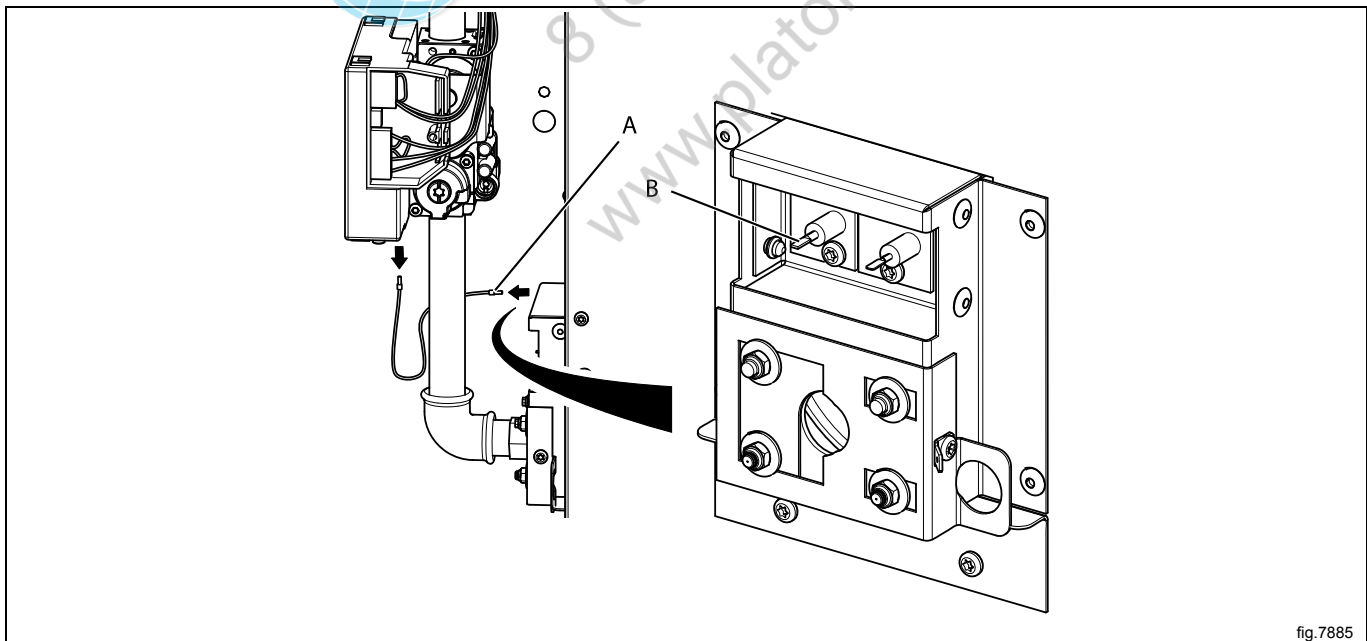
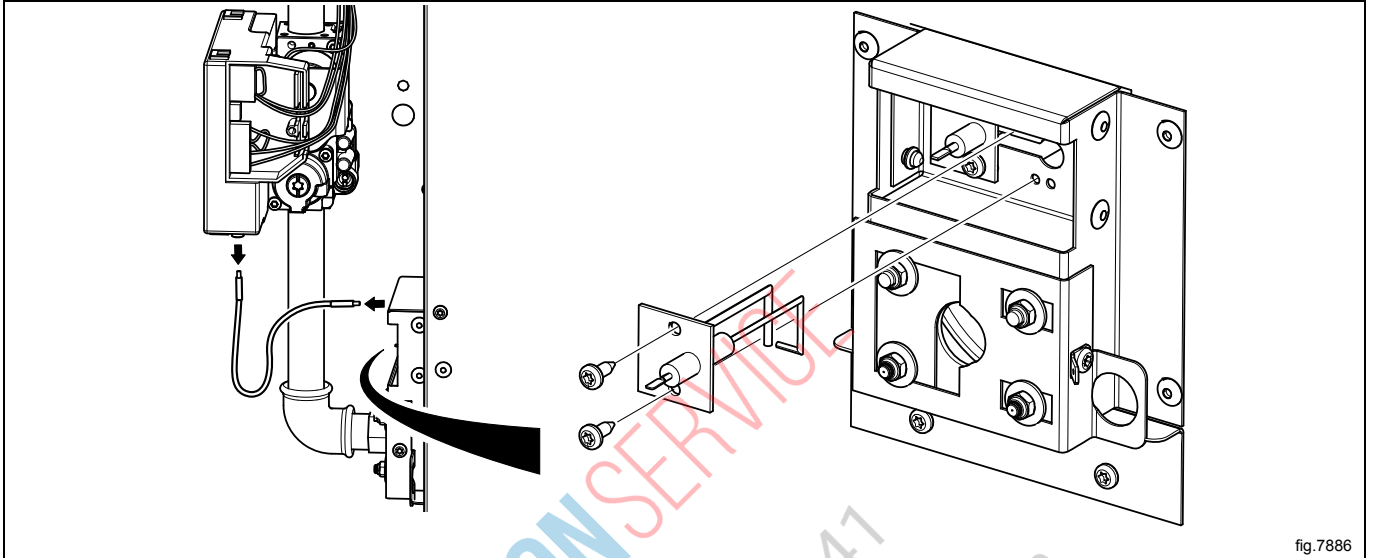

fig.7885

9.5 Replacement of ignition cable

- Shut off the manual gas valve.
- Disconnect the power to the machine.
- Demount the rear panel.
- Disconnect the ignition cable.
- Demount the ignition electrode.



Mount the new ignition electrode and connect the ignition cable.

Adjusting ignition electrode

The distance from the ignition electrode to the gas burner must be 5 mm. The spark gap must be 3 mm.

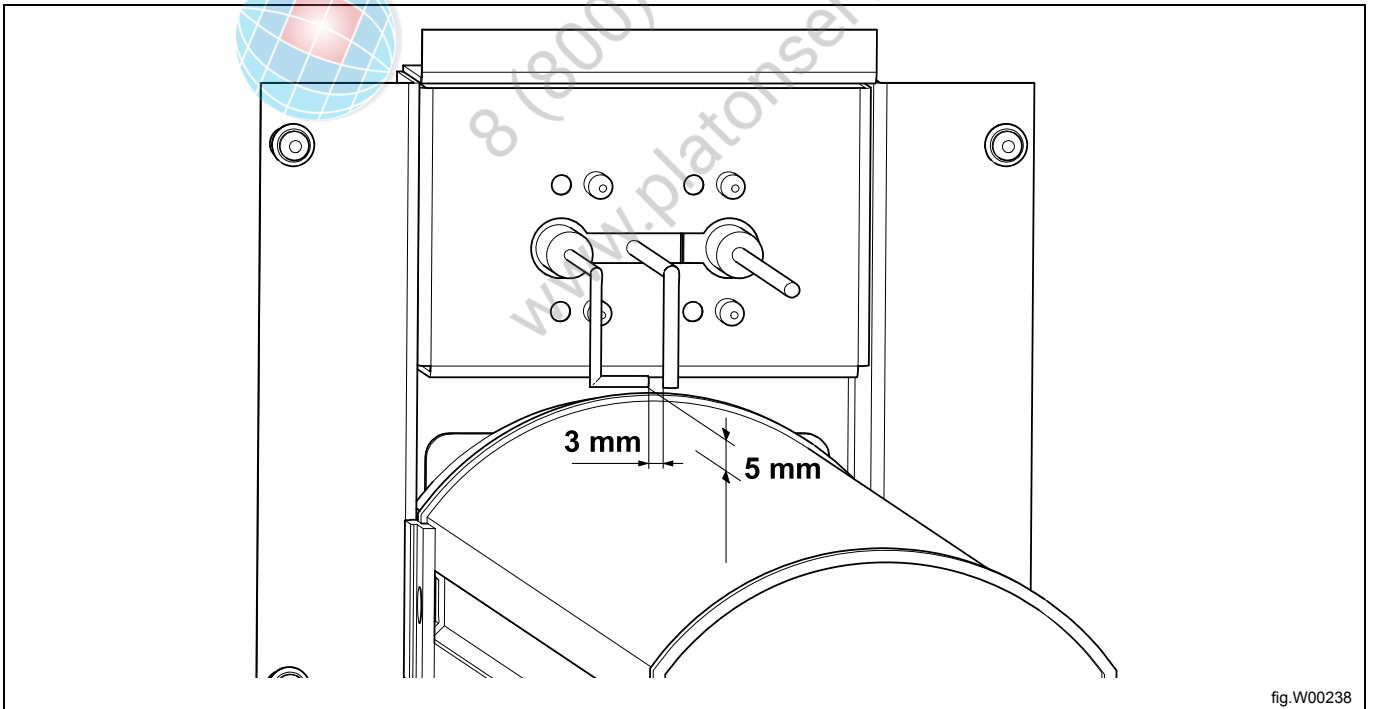

9.6 Converting instructions

- Disconnect the power to the machine.
- Demount the back panel.
- Unscrew the screw to the locking panel. Pull out the locking panel to release the gas pipe.
- Remove the nozzle (1).
- Mount the new supplied nozzle.
- Push the pipe with the new nozzle back in position.
- Push the locking panel back in position and tighten the screw.
- Replace/mount the air reducing plate according to the table.

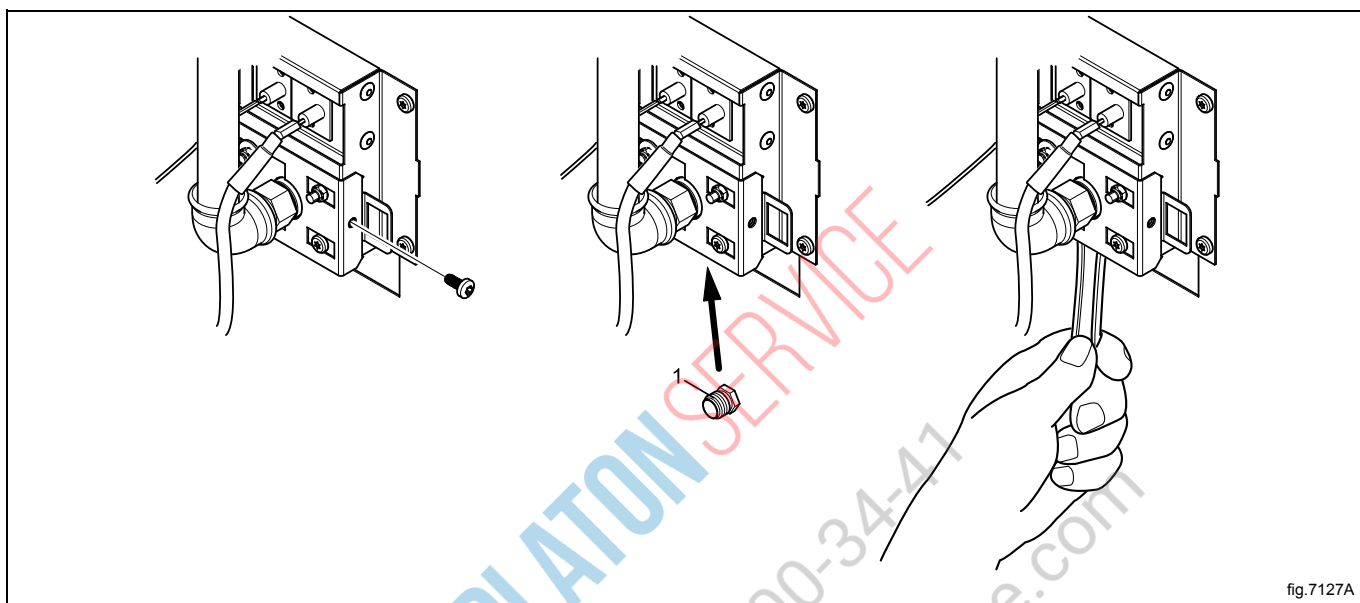

fig.7127A

- Loosen the measuring branch screw (2) 1/4 turn; connect a manometer to the measuring branch.
- Connect the power to the machine and select a program with heat.
- Start the machine.
- Set the correct nozzle pressure according to the table on setting screw (4) under the cover screw (3).

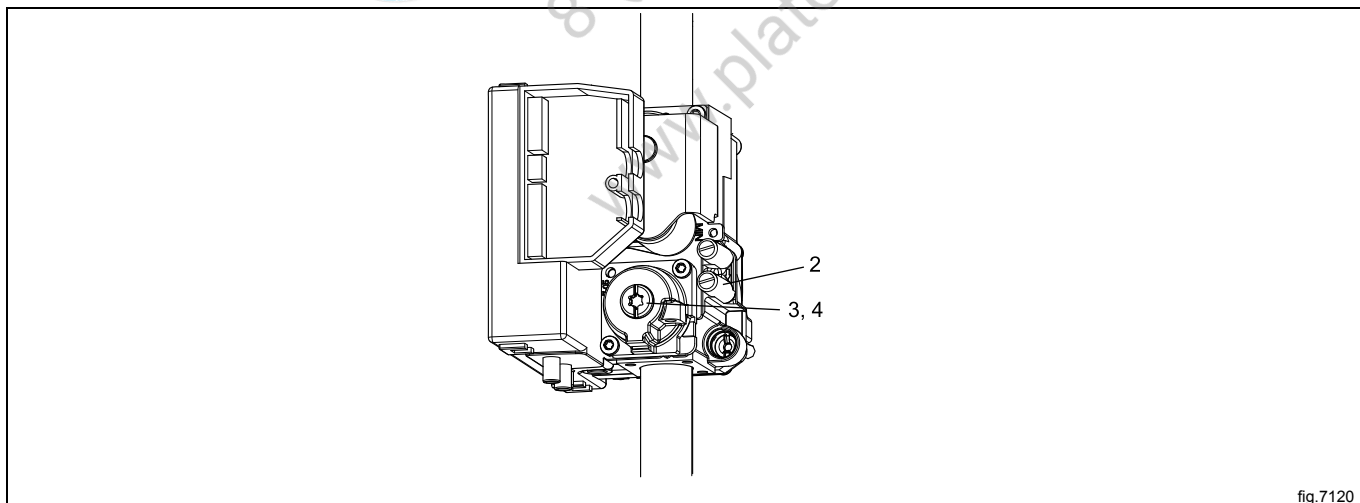

fig.7120

- Check that the gas flame burns evenly.
- Mount the cover screw (3).
- Remount the back panel.

9.7 Table of pressure and adjustment

Liquied petroleum gases	Gas category	Inlet pressure (mbar)	Injector pressure (mbar)	Injector size (ø mm)	Air reducing plate (mm)	Label number	May be available in following countries
Butane mixture / Propane mixture	3+	28-30 / 37	No regulation	2.30	No	490375643	BE, CH, CY, CZ, ES, FR, GB, GR, IE, IT, LT, LU, LV, PT, SK, SI
Butane	3B/P	30, 37, 50	28	2.30	No	490375644	BE, CY, DK, EE, FI, FR, GB, HU, IT, LT, NL, NO, SE, SI, SK, RO, HR, TR, BG, IS, LU, MT, PL, AT, CH, DE, SK
Propane	3P	30, 37, 50	28	2.40	No	490375645	FI, NL, RO, BE, CH, CZ, IE, IT, ES, FR, GR, GB, HR, LT, NL, PL, PT, SI, SK, AT, CH, DE, NL, LU, SK

Natural gas	Gas category	Inlet pressure (mbar)	Injector pressure (mbar)	Injector size (ø mm)	Air reducing plate (mm)	Label number	May be available in following countries
	2H, 2E	20	8	4.00	No	Default	AT, BG, CZ, DK, EE, FI, GR, HR, HU, IS, IE, IT, LV, LT, NO, PT, RO, SK, SI, ES, SE, CH, TR, GB, DE, PL, LU
	2E+	20 / 25	No regulation	3.30	No	490375641	BE, FR
	2E (G20)	20	8	4.00	No	490375642	NL
	2L (G25)	25	12				
	2(43.46-45.3 MJ/m ³ (0 °C)) (G25.3)	25	12				
	2LL (G25)	20	12	4.00	No	490375642	DE

Gas category	Total nominal gas consumption (MJ/h)	Inlet pressure (kPa)	Injector pressure (kPa)	Injector size (ø mm)	Air reducing plate (mm)	Label number	May be available in following countries
Natural	76	1.13	0.80	4.00	No	Default	AU
Propane	76	2.75	2.64	2.40	No	490375861	AU

Gas category	Total nominal gas consumption (MJ/h)	Inlet pressure (kPa)	Injector pressure (kPa)	Injector size (ø mm)	Air reducing plate (mm)	Label number	May be available in following countries
Natural	76	1.13	0.80	4.00	No	490375862	NZ
General product LPG	76	2.75	2.64	2.30	No	490375863	NZ

9.8 Test run

- Loosen the measuring branch screw (2) 1/4 turn; connect a manometer to the measuring branch.
- Select a program with heat.
- Start the machine.
- Check the nozzle pressure, see "Table of pressure and adjustment".
- If necessary adjust the regulator setting screw (4) behind the cover screw (3). Replace the cover screw (3) if removed.
- Check that the gas is burning evenly.

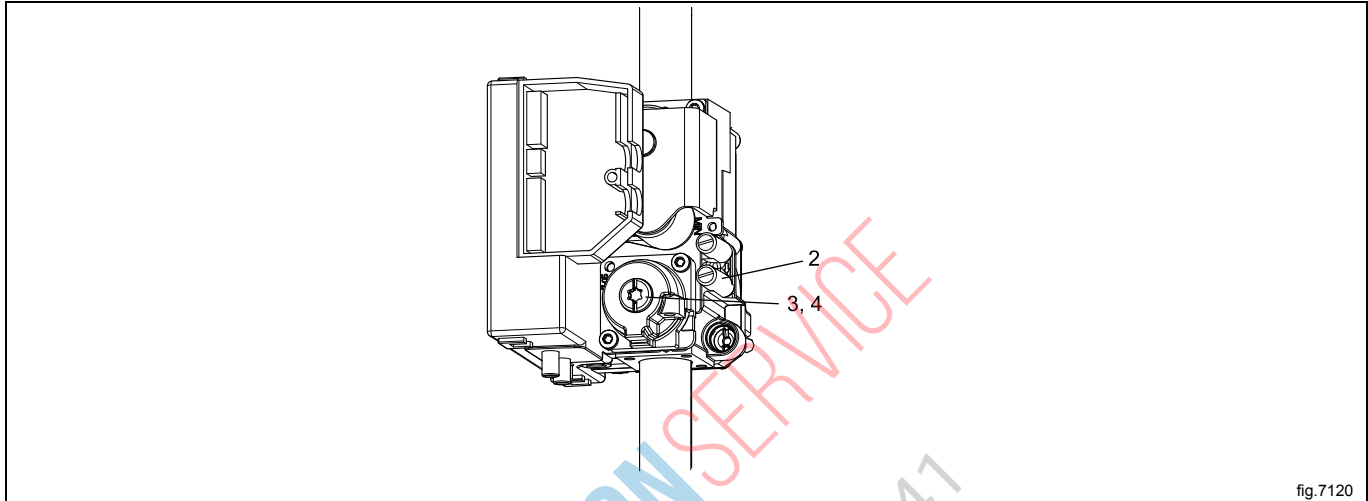

PLATON SERVICE

8 (800) 500-34-47

www.platonservice.com

10 Heating unit, steam

10.1 Replacement of steam calorifier

Disconnect the power to the machine.

Shut off the steam and demount the steam inlet and outlet hose.

Demount the rear panel.

Loosen the screws on the bracket that is holding the steam calorifier and push the bracket towards you. Carefully lift off the steam calorifier.

Note that the steam calorifier also needs to be loosened from the mounting rail at the bottom.

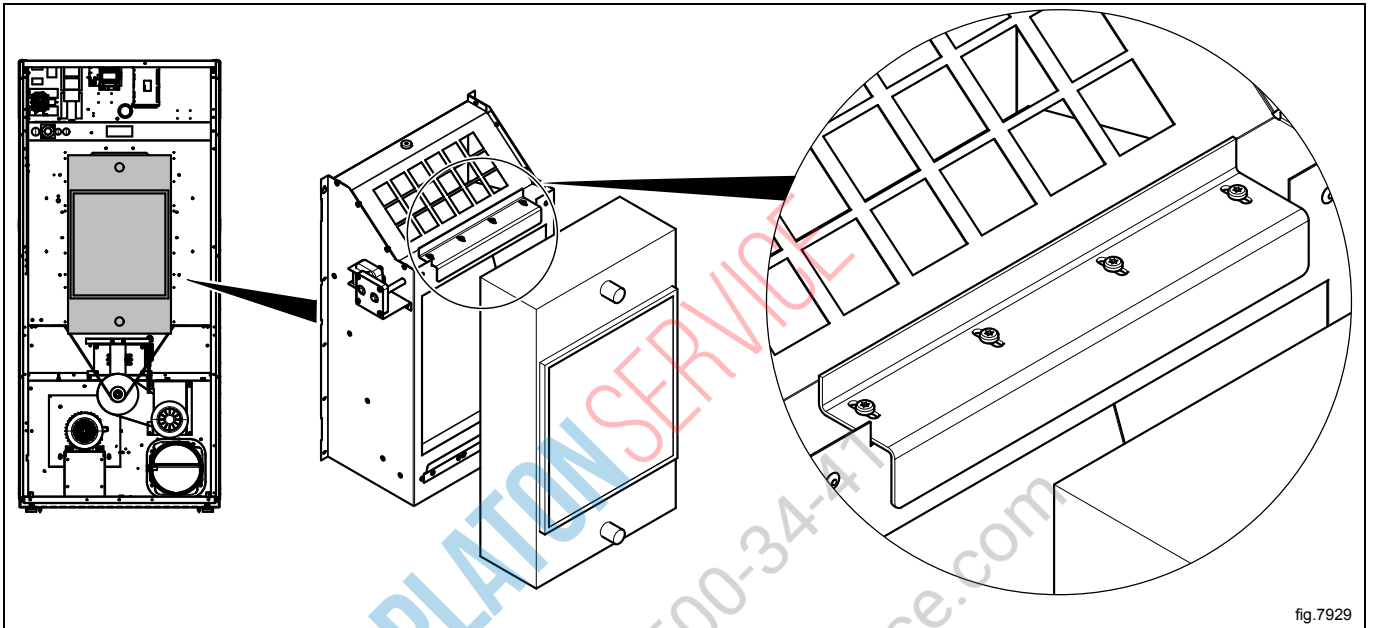

Mount the new steam calorifier. Tighten the screws a bit first when putting the steam calorifier in position. Loosen the screws again and push the steam calorifier and bracket inwards as far as possible. Tighten the screws when it is in position.

Note!

To prevent heat leakage it is important to put back the steam calorifier in correct position.

10.2 Replacement of damper motor

Disconnect the power to the machine.

Demount the rear panel.

Demount the bracket (A) from the machine and demount the damper motor (B) from the bracket.

Mount the new damper motor on the bracket and then remount the bracket on the machine.

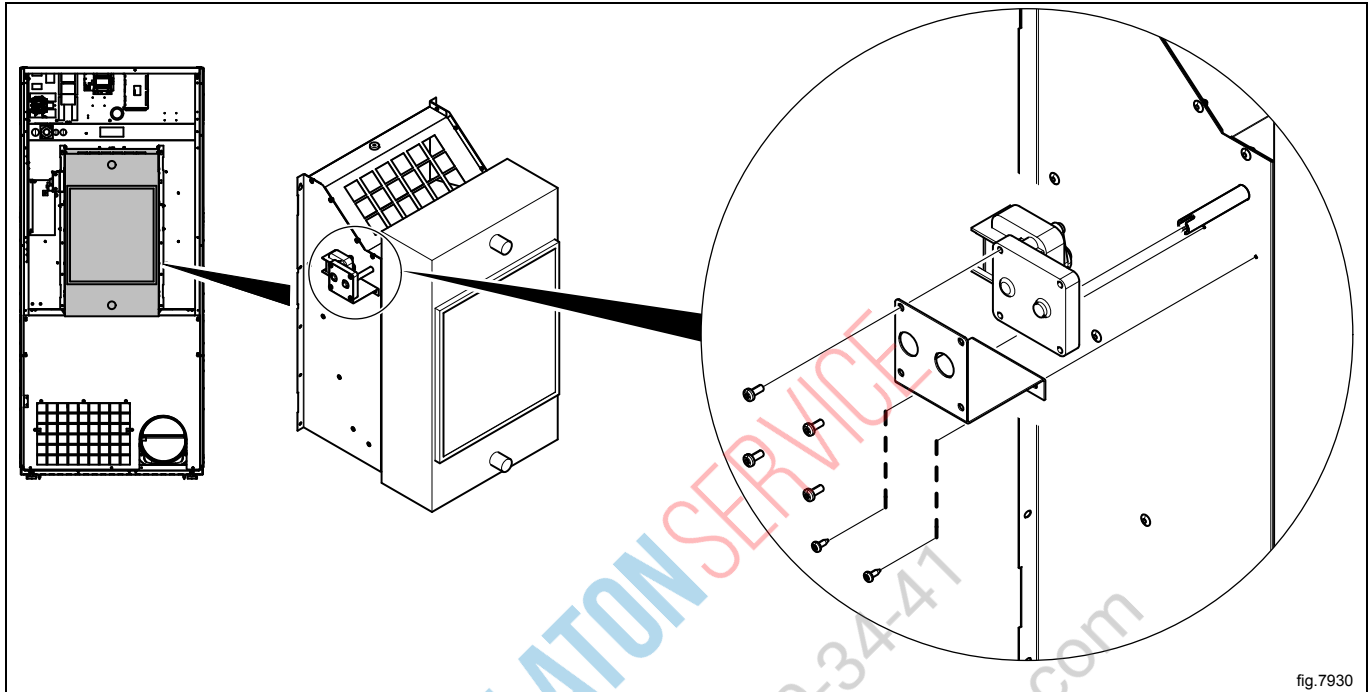

Remount the rear panel.



8 (800) 500-34-41
www.platonservice.com

11 Drum

11.1 Replacement of drum

Disconnect the power to the machine.

Demount the rear panel and the top panel.

Loosen the belt tensioner

Lift the drum belt off the drum and pull it backwards.

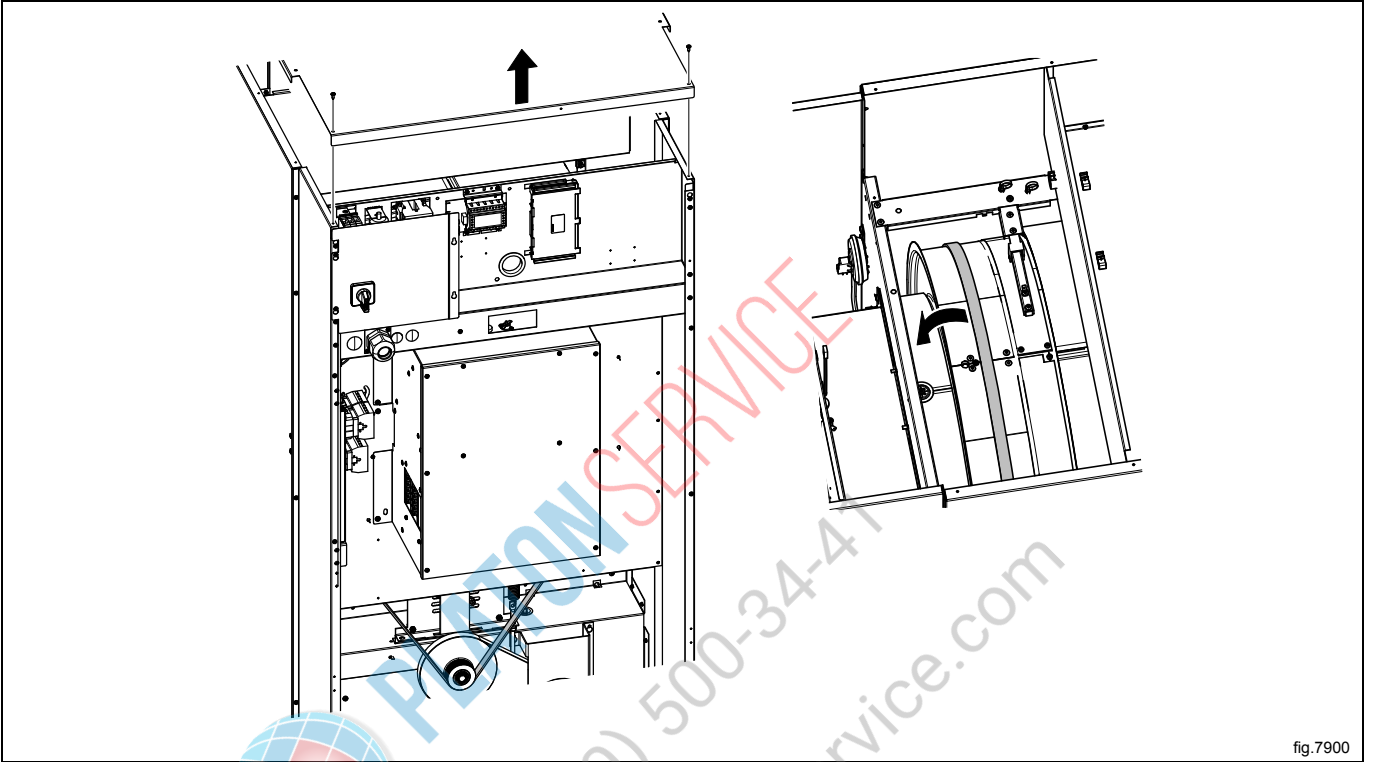

fig.7900

Demount the hinges and remove the door. Remove the upper hinge first.

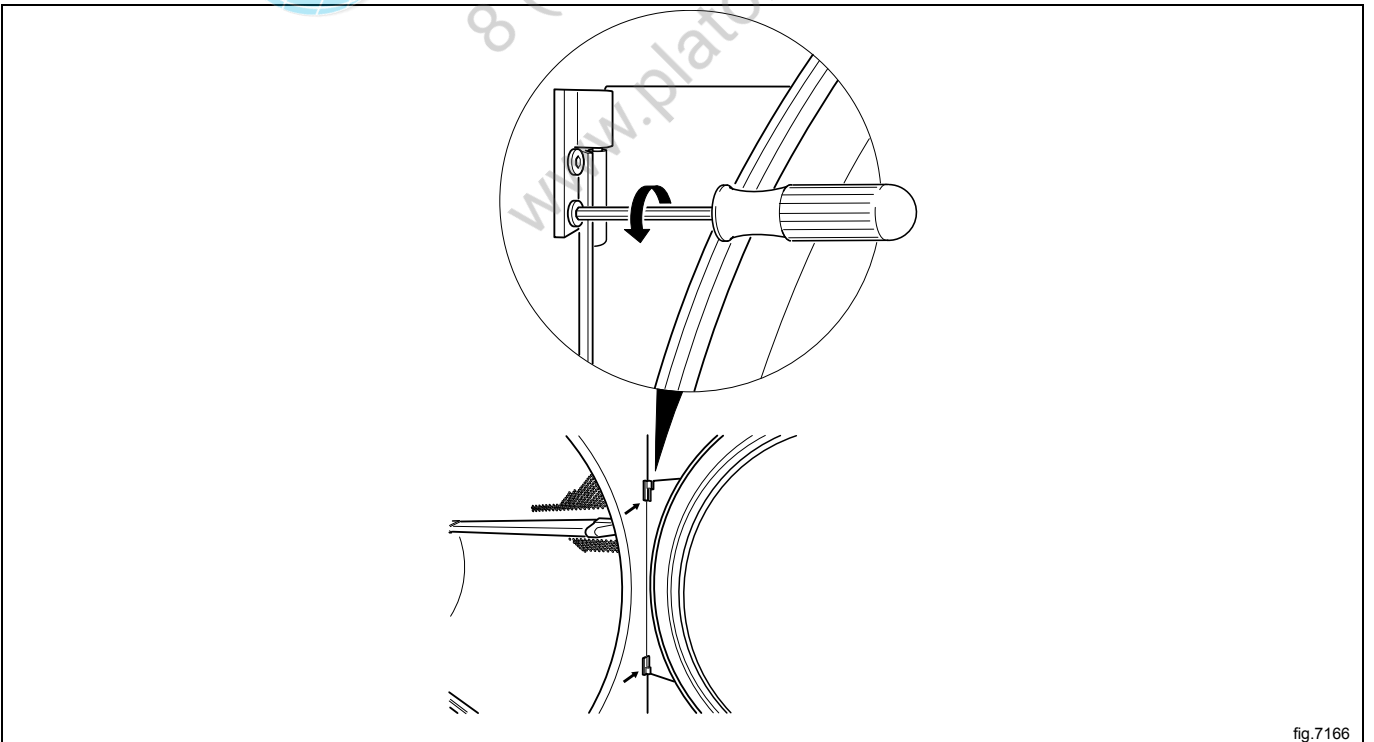
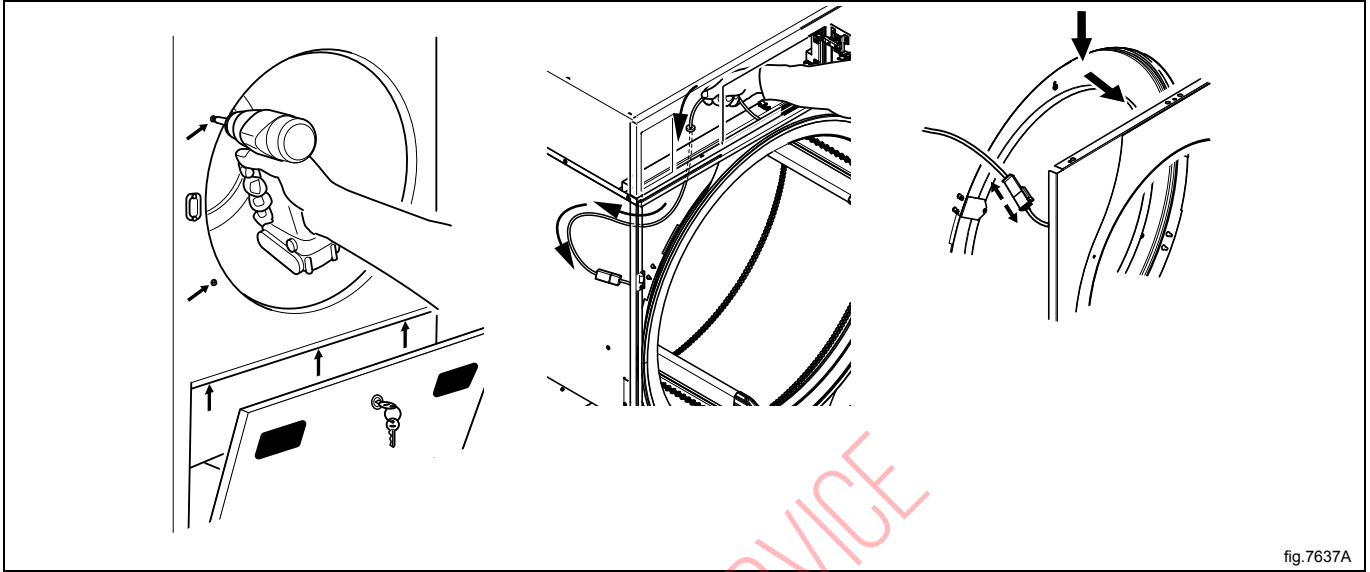
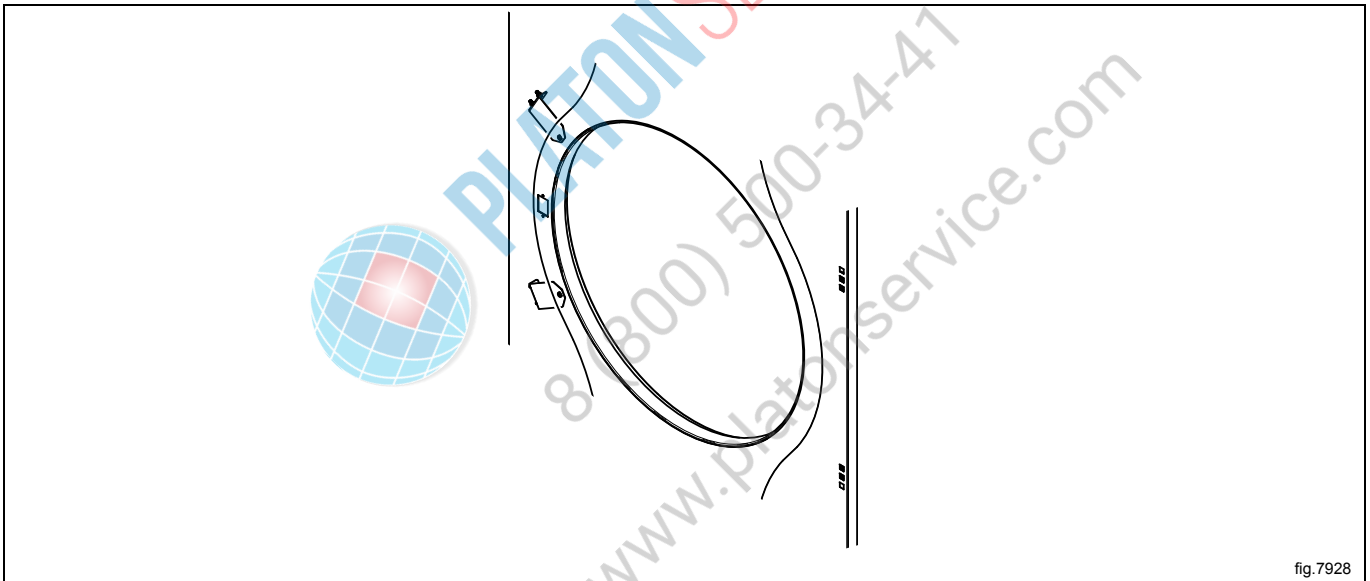

fig.7166

Remove the screws on the front panel and carefully loosen the panel. Push the door switch cable down through the hole in order to access the cable and then disconnect the cable. Remove the panel.



Loosen the screws and remove the brackets.



Remove the screws and the bearing house (A).

1. Shows a machine without RMC. Remove the bolt (B) and the washer (C).
2. Shows a machine with RMC. Loosen the screw and pull the RMC flange to the side in order to remove the bolt (B) and the washer (C).

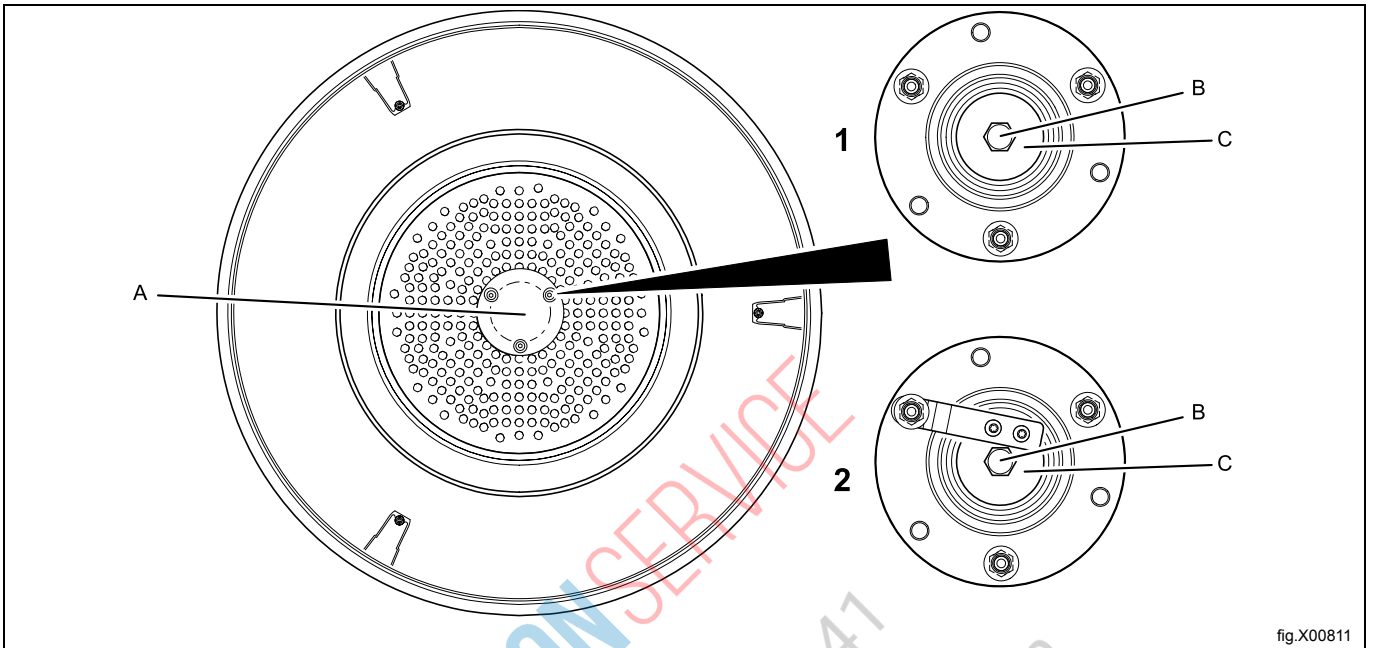

Demount the RMC with arm.

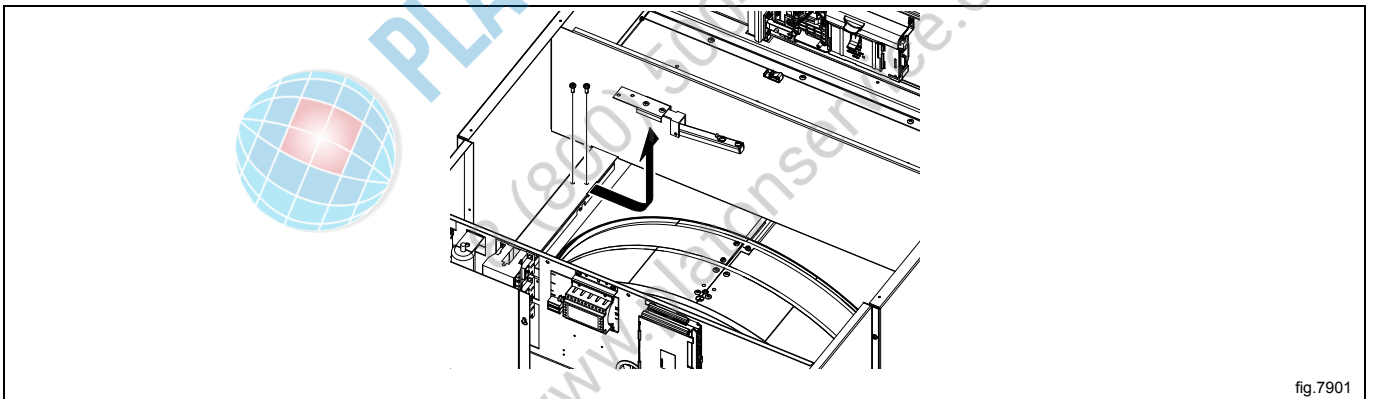

Carefully lift out the drum. When mounting the new drum, first fasten the belt temporarily on the drum, then put the drum in position

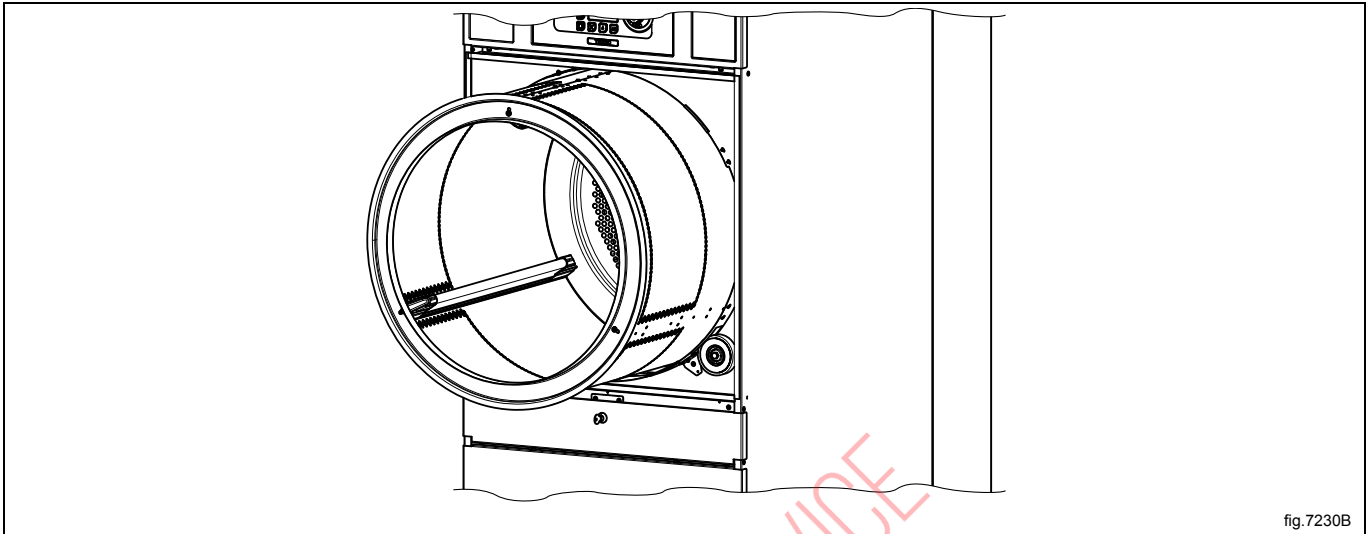

fig.7230B

Remount the RMC with arm.

Fasten the bolt and the washer and remount the bearing house. Use tightening torque $20 \text{ Nm} \pm 3 \text{ Nm}$.

On machines with RMC; pull the RMC flange back in position and tighten the screw. Use tightening torque $5 \text{ Nm} \pm 0.5 \text{ Nm}$.

Fasten the belt and make sure the belt is in position. Fasten the belt tensioner.

Remount the rear panel and the top panel.

Connect the door switch cable and push the cable in over the drum and pull it upwards.

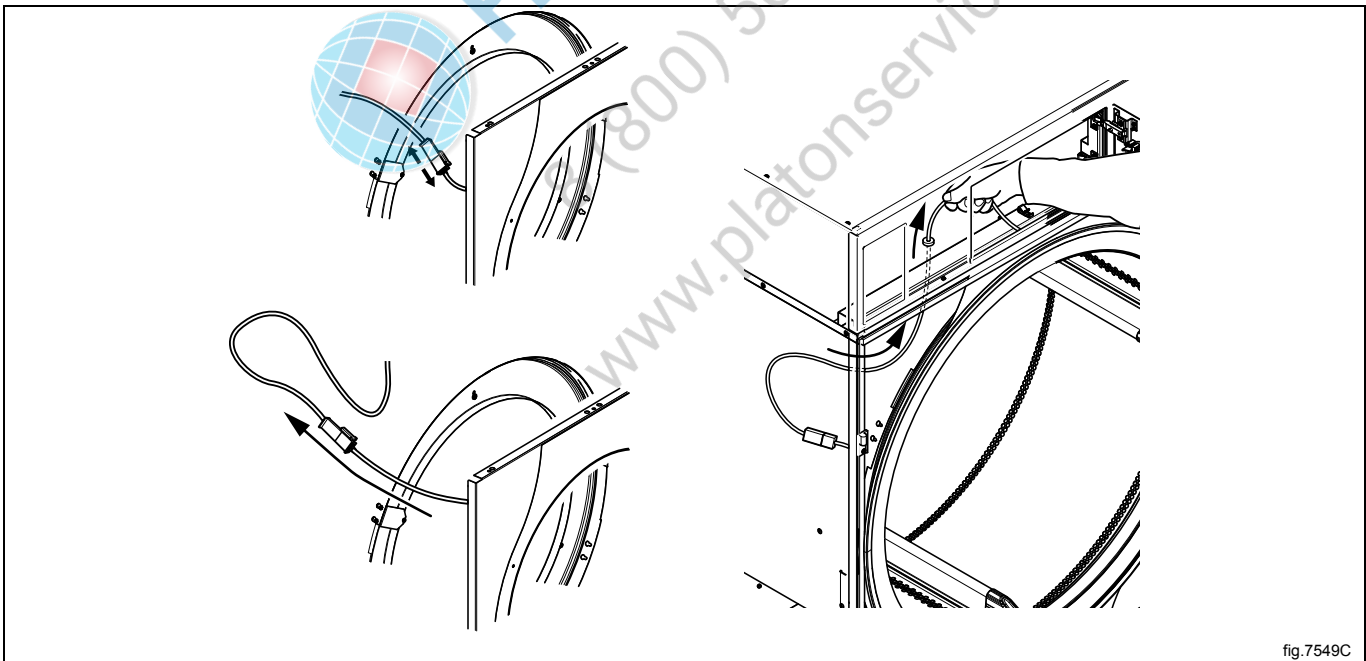

fig.7549C

Remount the front panel.



Ensure that the door switch cable does not get damaged when remounting the front panel.



Remount the door.

11.2 Replacement of bearing

Disconnect the power to the machine.

Demount the rear panel and the top panel.

Loosen the belt tensioner

Lift the drum belt off the drum and pull it backwards.

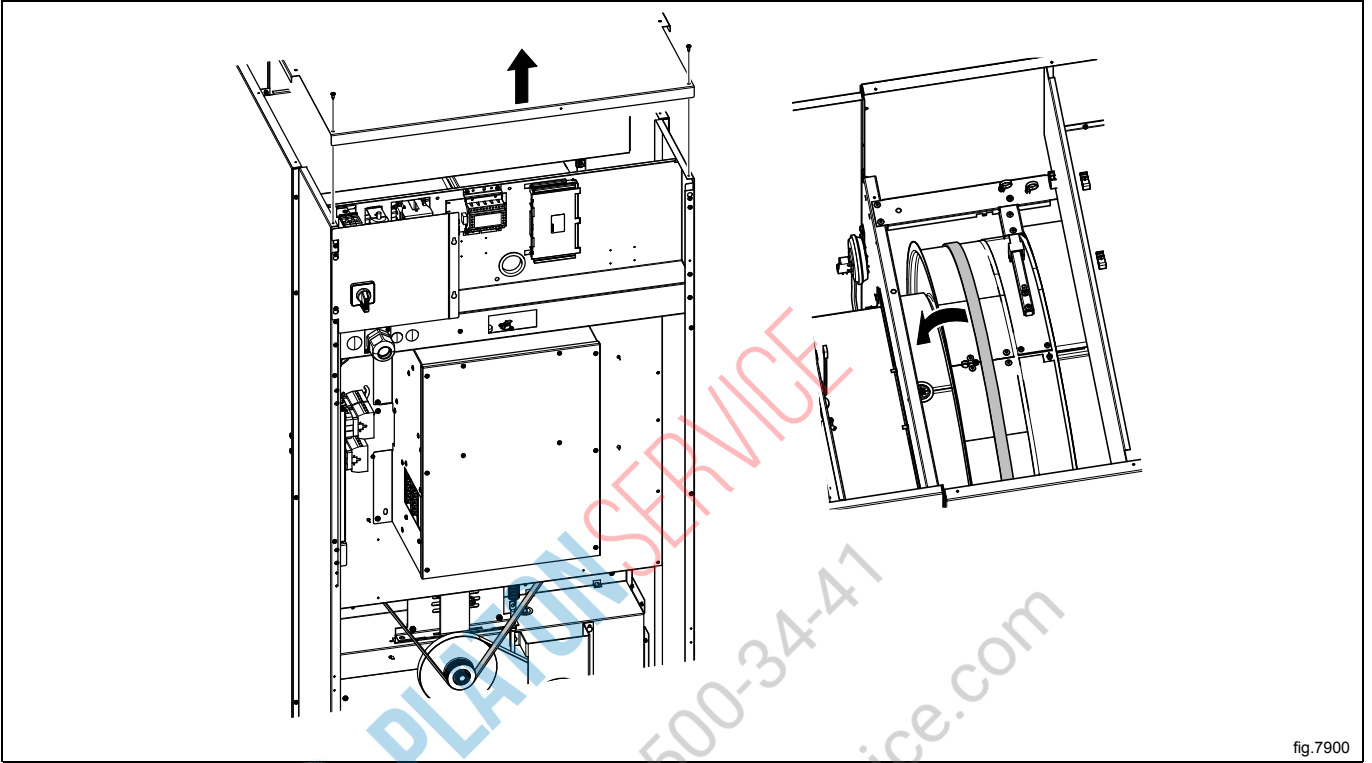

fig.7900

Demount the hinges and remove the door. Remove the upper hinge first.

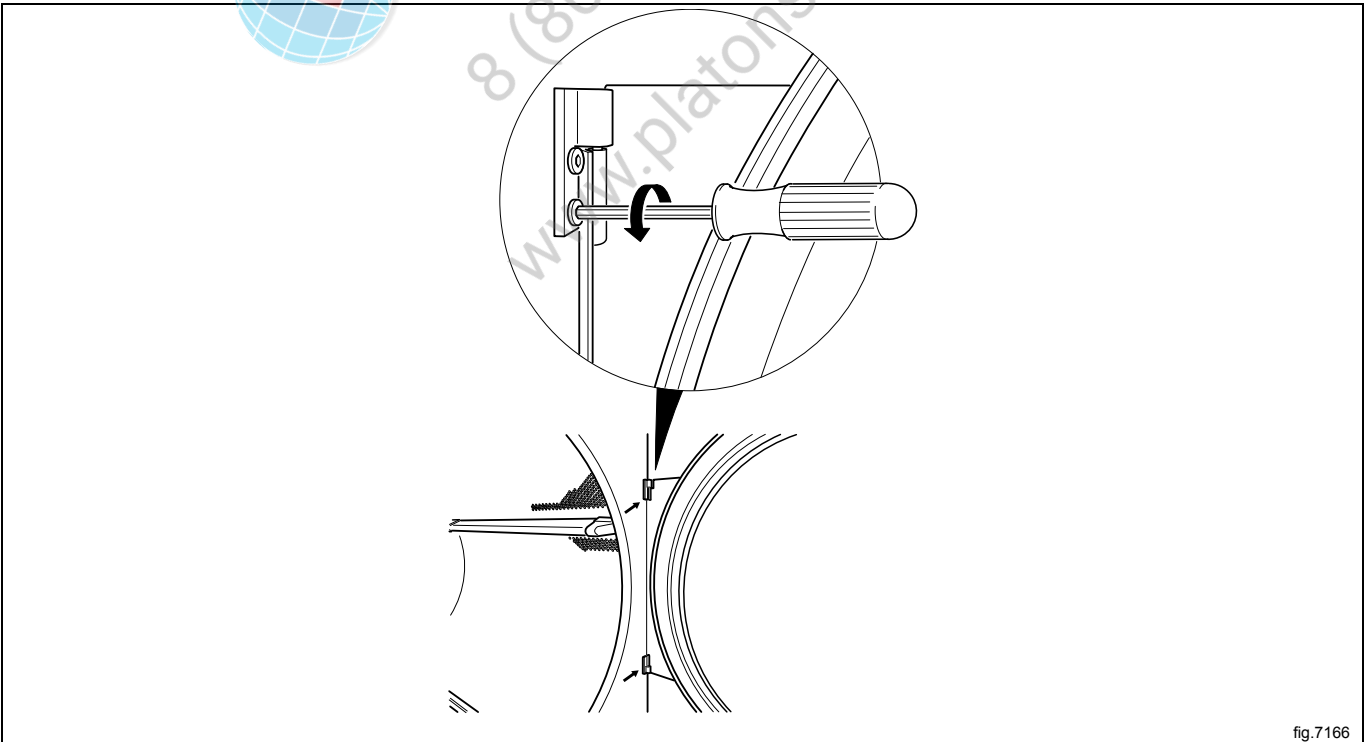
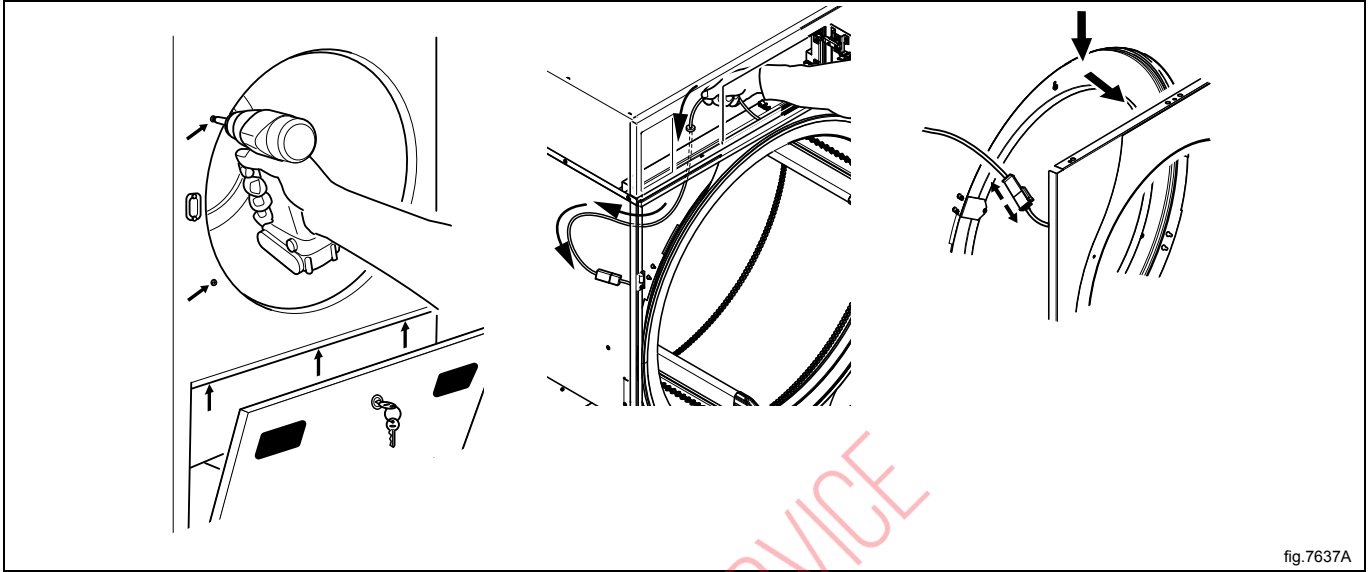
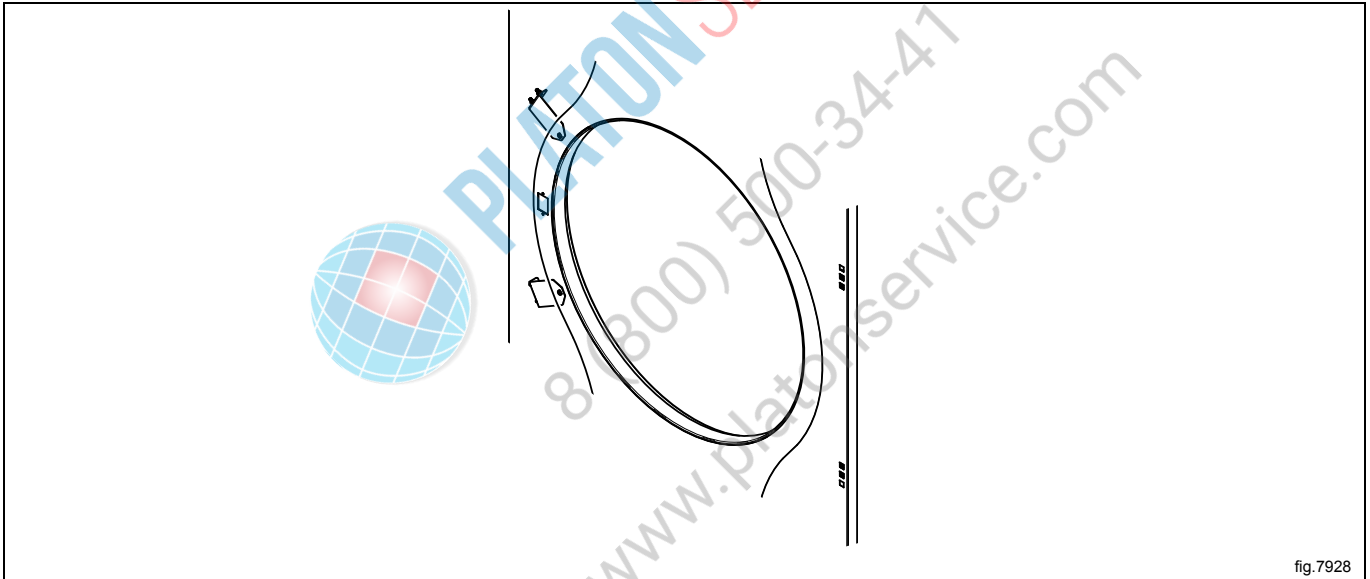

fig.7166

Remove the screws on the front panel and carefully loosen the panel. Push the door switch cable down through the hole in order to access the cable and then disconnect the cable. Remove the panel.



Loosen the screws and remove the brackets.



Remove the screws and the bearing house (A).

1. Shows a machine without RMC. Remove the bolt (B) and the washer (C).
2. Shows a machine with RMC. Loosen the screw and pull the RMC flange to the side in order to remove the bolt (B) and the washer (C).

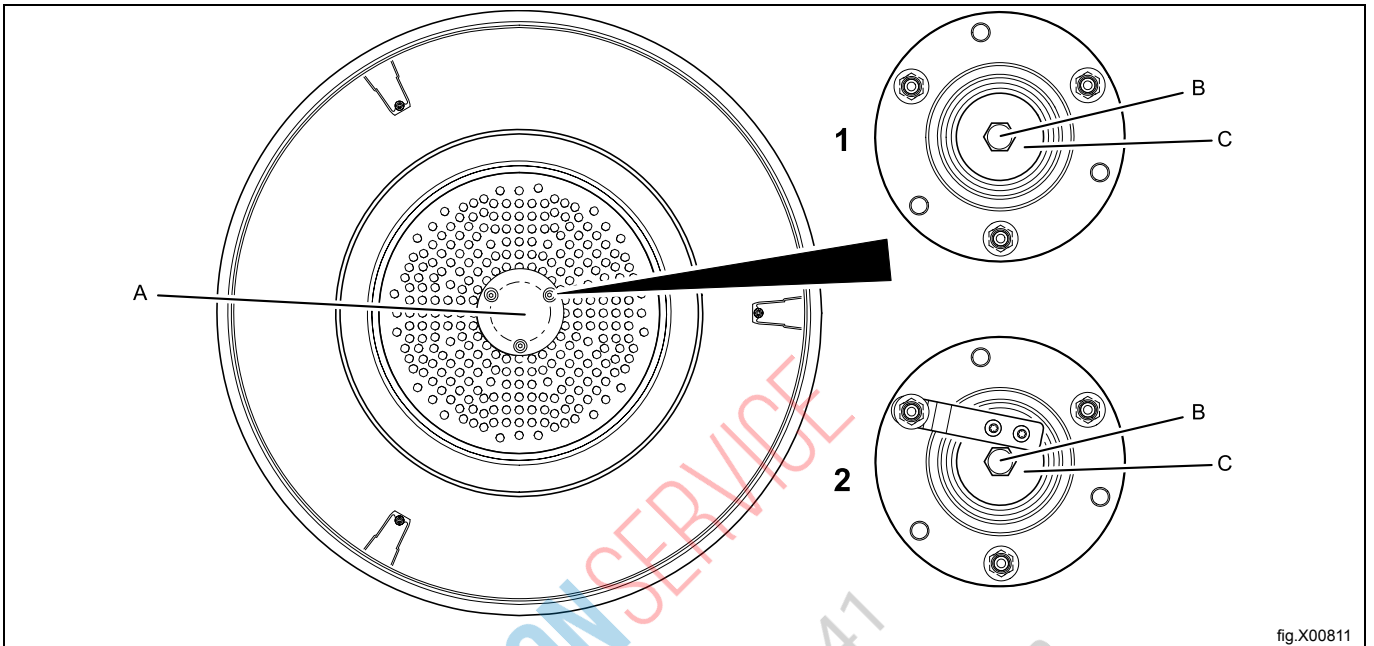

Demount the RMC with arm.

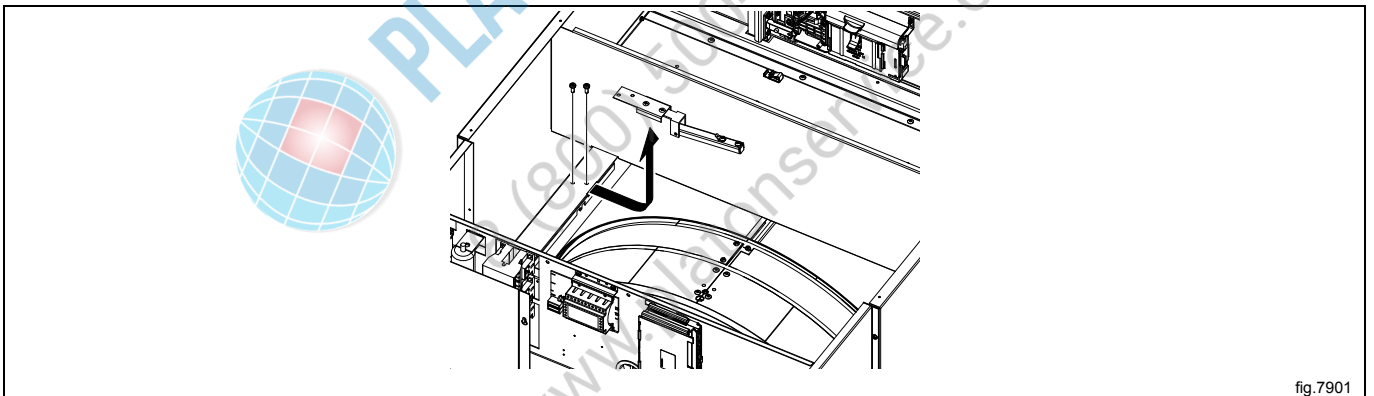

Carefully lift out the drum.

Put the drum on the floor.

Remove the bolts and washers (D) and mount the new bearing. Use tightening torque 5 Nm.

1. Shows a machine without RMC.
2. Shows a machine with RMC.

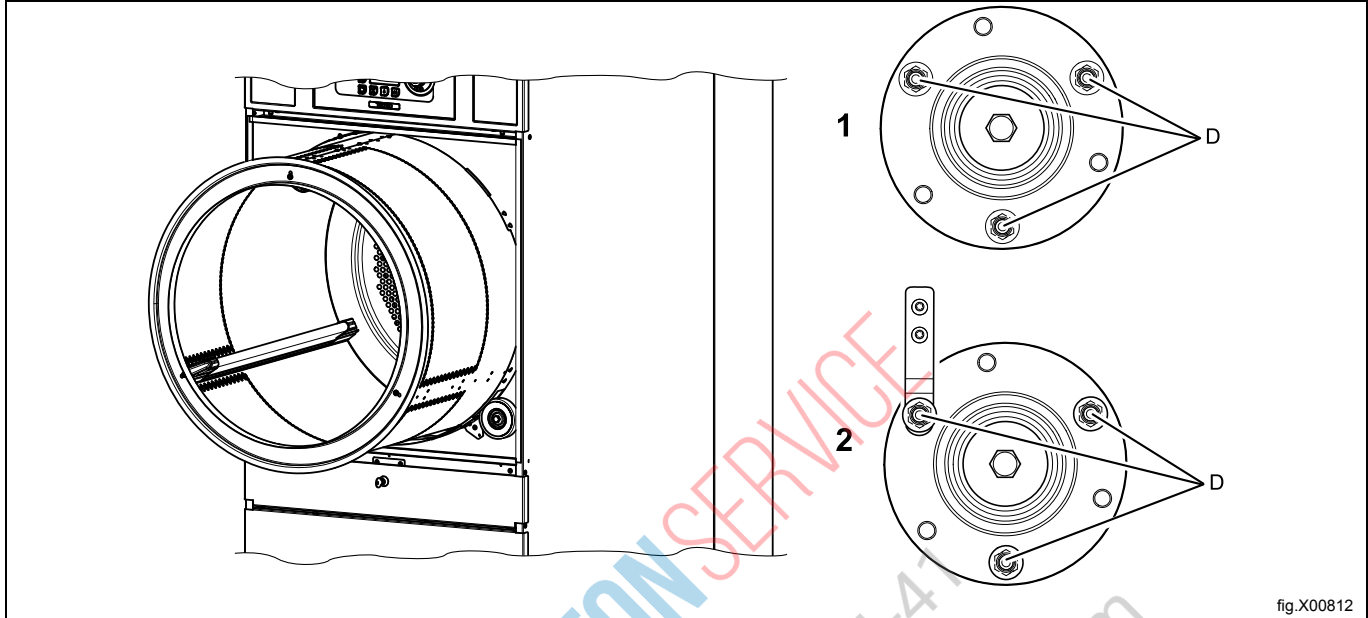

fig.X00812

Remount the RMC with arm.

Fasten the bolt and the washer and remount the bearing house. Use tightening torque $20 \text{ Nm} \pm 3 \text{ Nm}$.

On machines with RMC; pull the RMC flange back in position and tighten the screw. Use tightening torque $5 \text{ Nm} \pm 0.5 \text{ Nm}$.

Fasten the belt and make sure the belt is in position. Fasten the belt tensioner.

Remount the rear panel and the top panel.

Connect the door switch cable and push the cable in over the drum and pull it upwards.

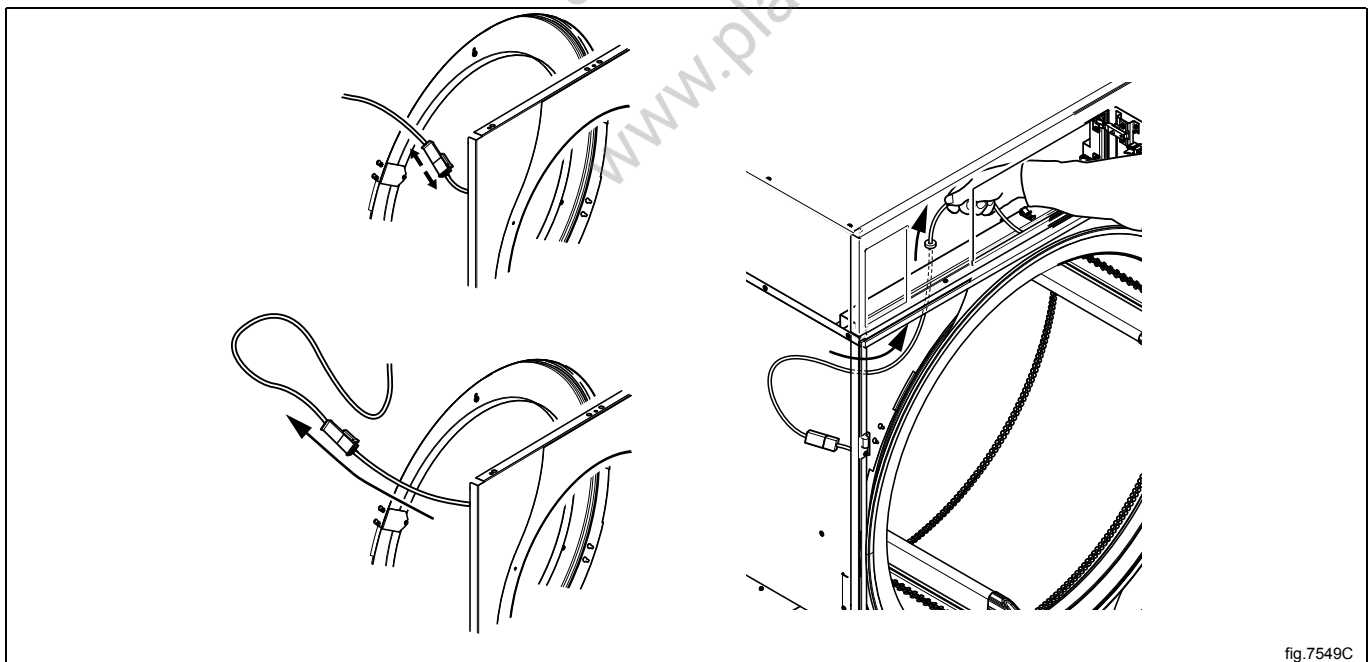

fig.7549C

Remount the front panel.



Ensure that the door switch cable does not get damaged when remounting the front panel.



Remount the door.

11.3 Replacement of the belt around the drum

Disconnect the power to the machine.

Demount the rear panel and the top panel.

Loosen the belt tensioner

Lift the drum belt off the drum and pull it backwards.

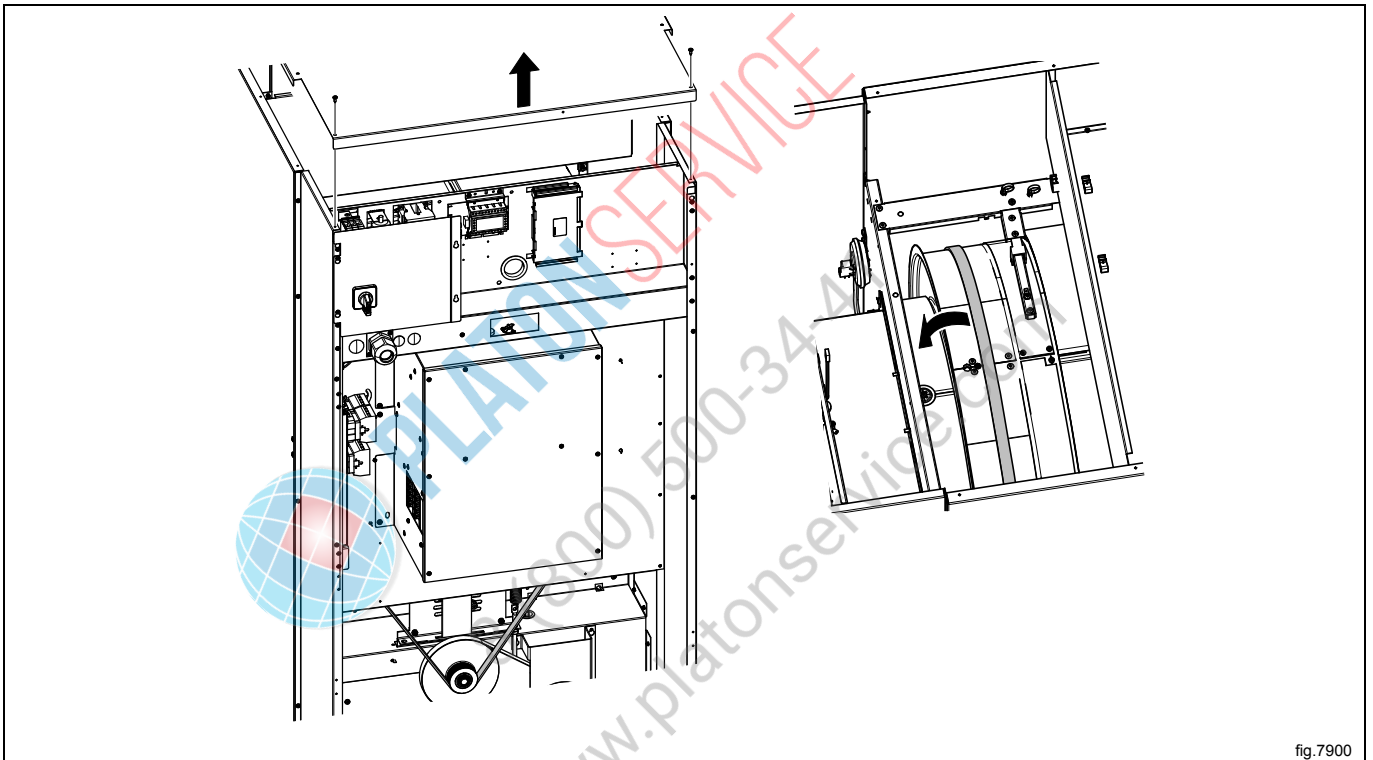
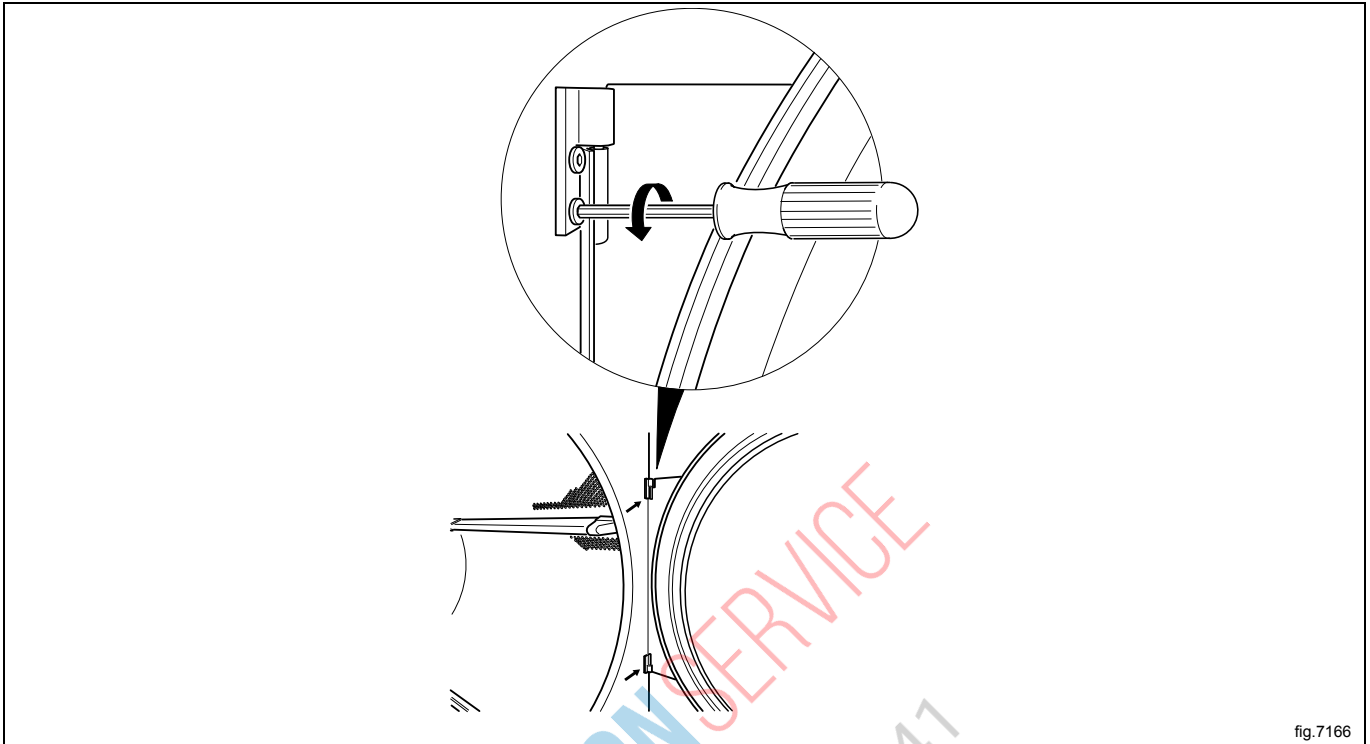
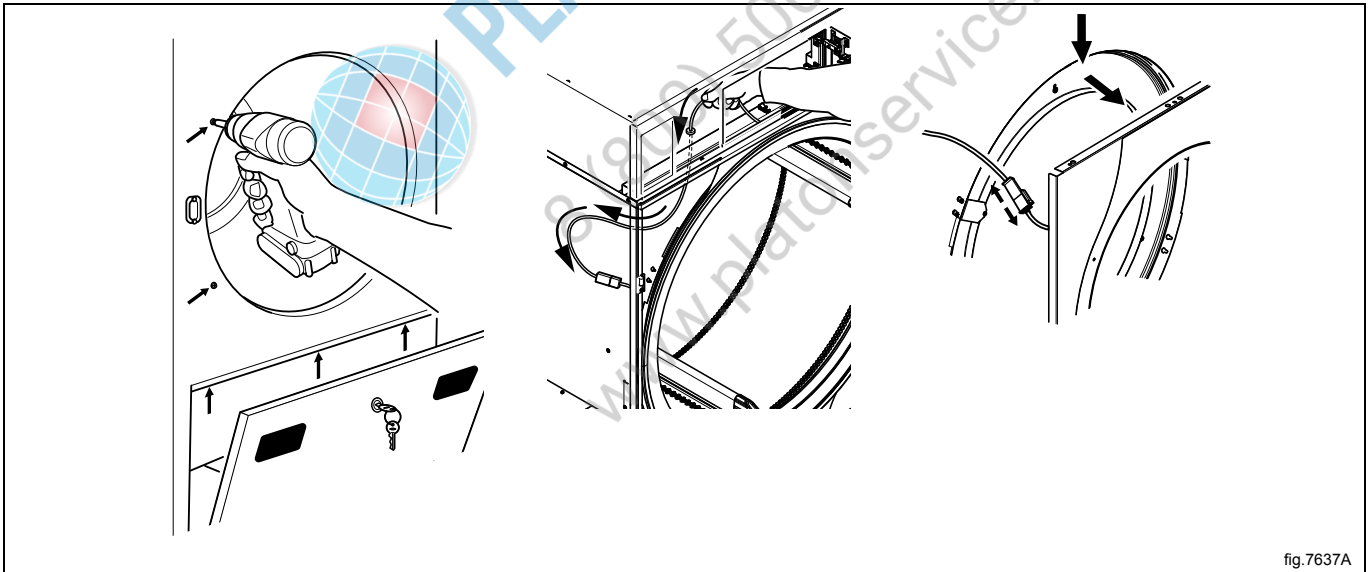

fig.7900

Demount the hinges and remove the door. Remove the upper hinge first.



Remove the screws on the front panel and carefully loosen the panel. Push the door switch cable down through the hole in order to access the cable and then disconnect the cable. Remove the panel.



Loosen the screws and remove the brackets.

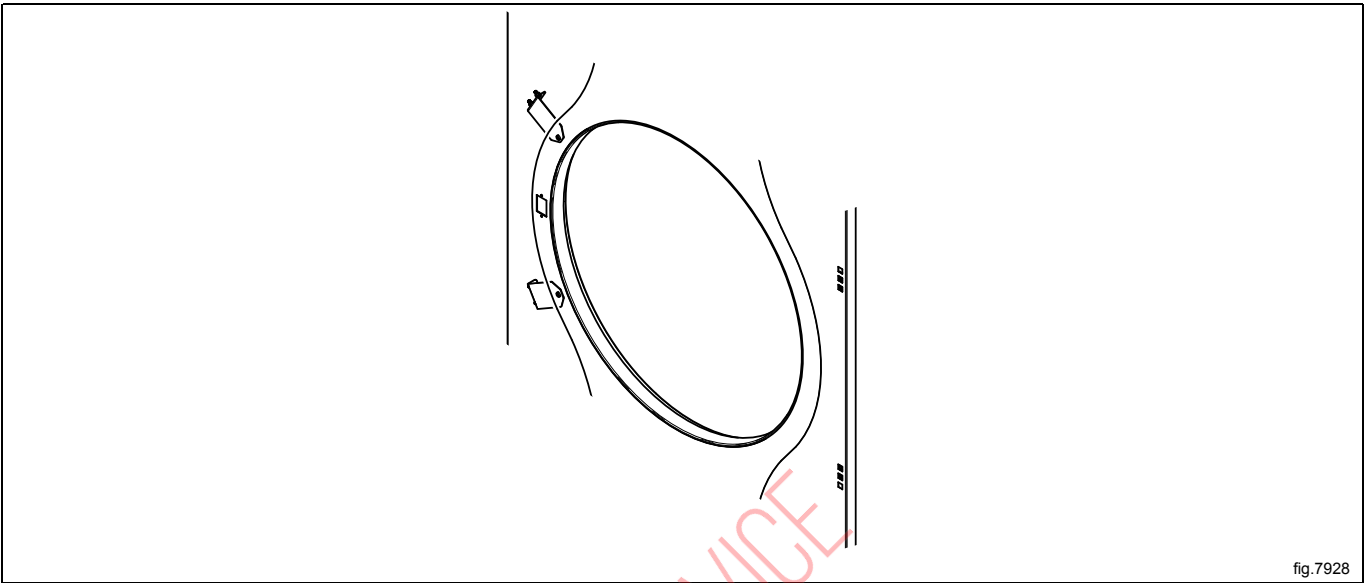

fig.7928

Remove the screws and the bearing house (A).

1. Shows a machine without RMC. Remove the bolt (B) and the washer (C).
2. Shows a machine with RMC. Loosen the screw and pull the RMC flange to the side in order to remove the bolt (B) and the washer (C).

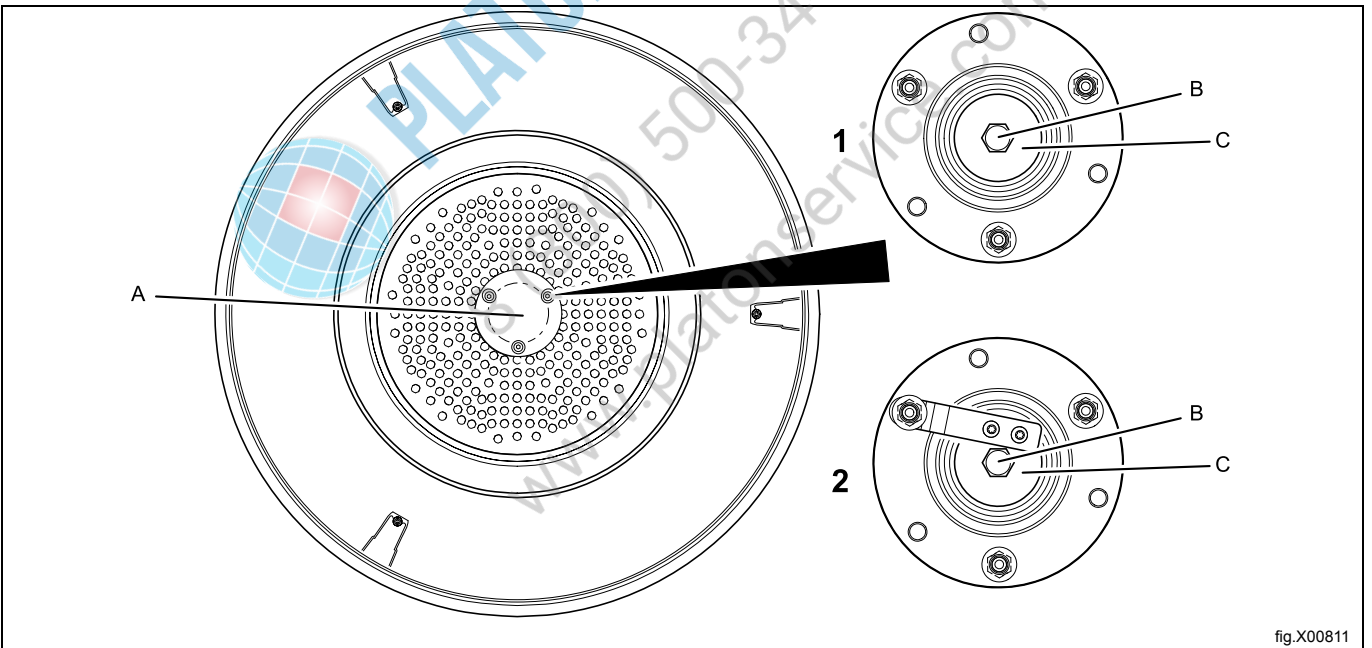
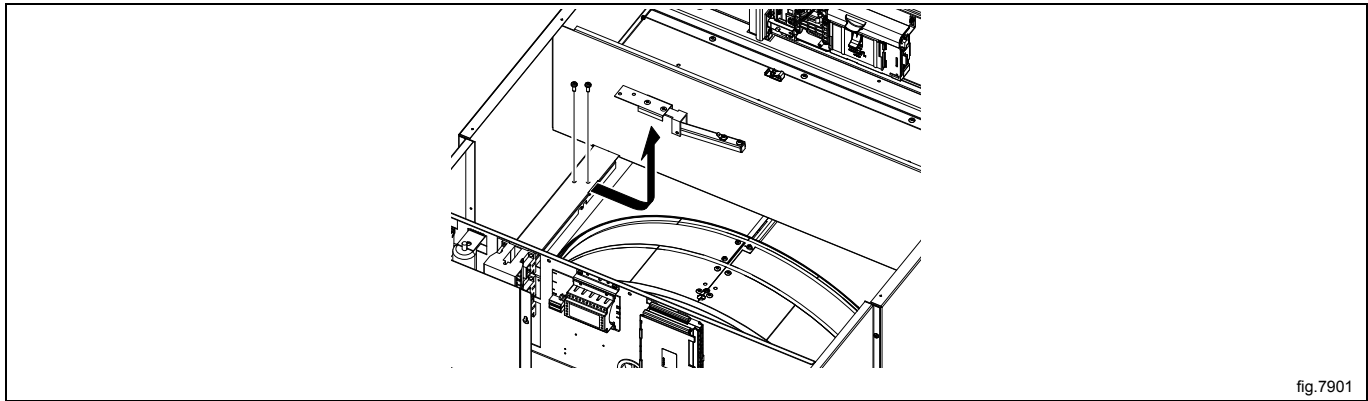

fig.X00811

Demount the RMC with arm.



Carefully lift out the drum and remove the belt.

When remounting the drum, first fasten the new belt temporarily on the outer drum in the machine, then put the drum in position.

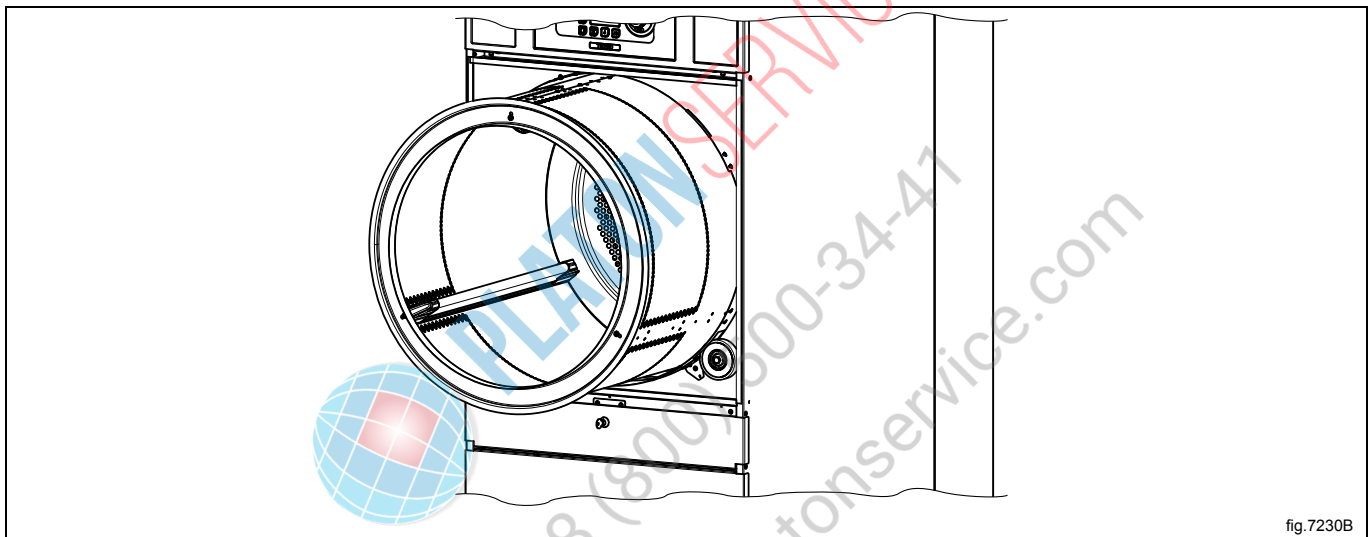

Remount the RMC with arm.

Fasten the bolt and the washer and remount the bearing house. Use tightening torque $20 \text{ Nm} \pm 3 \text{ Nm}$.

On machines with RMC; pull the RMC flange back in position and tighten the screw. Use tightening torque $5 \text{ Nm} \pm 0.5 \text{ Nm}$.

Fasten the belt and make sure the belt is in position. Fasten the belt tensioner.

Remount the rear panel and the top panel.

Connect the door switch cable and push the cable in over the drum and pull it upwards.

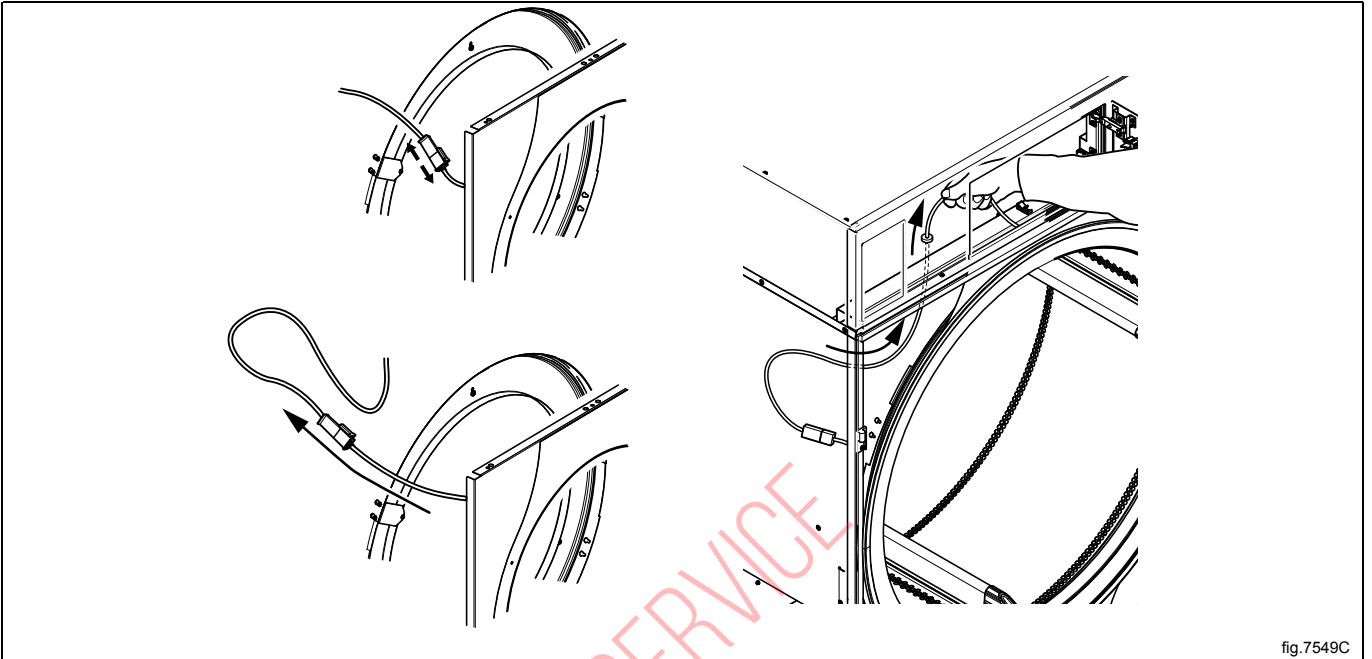

fig.7549C

Remount the front panel.



Ensure that the door switch cable does not get damaged when remounting the front panel.



Remount the door.



PLATON SERVICE
 8 (800) 500-34-47
 www.platonservice.com

11.4 Replacement of rear sealing

Disconnect the power to the machine.

Demount the rear panel and the top panel.

Loosen the belt tensioner

Lift the drum belt off the drum and pull it backwards.

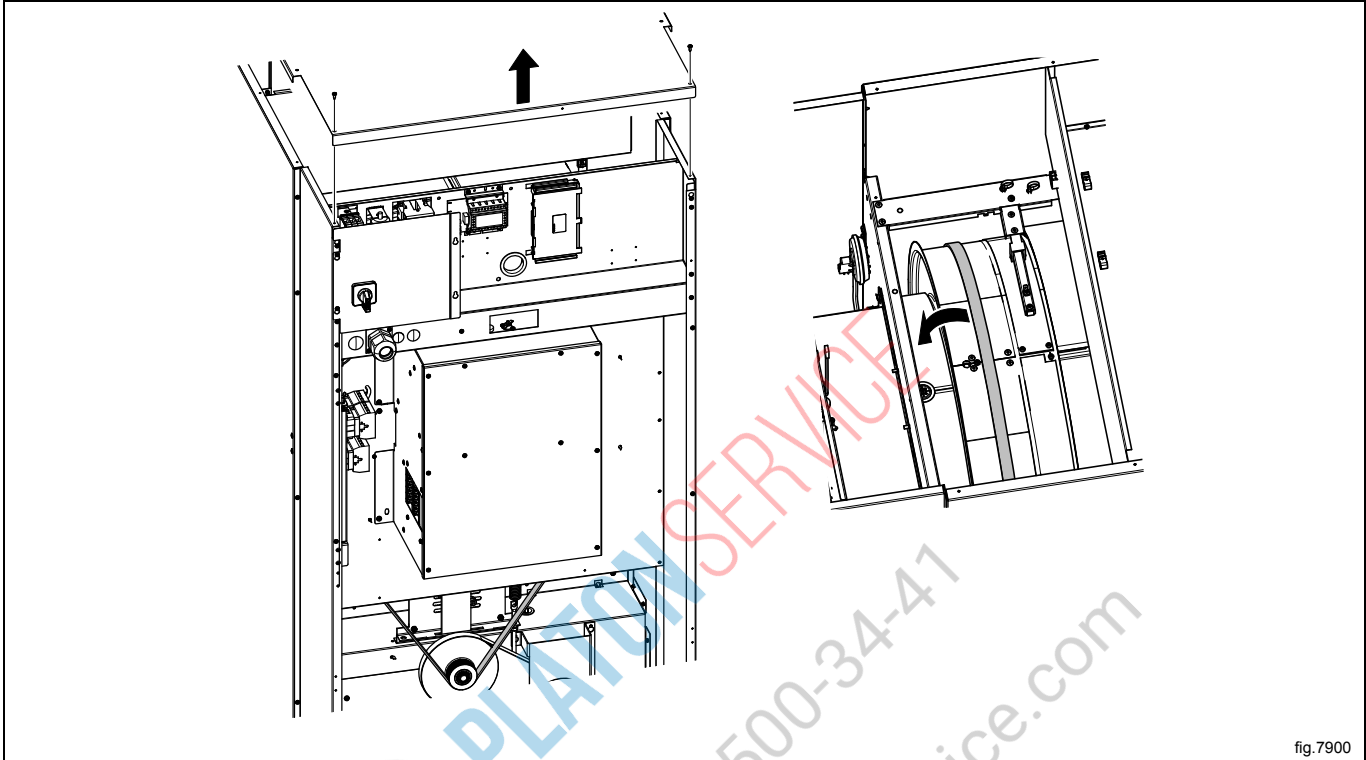

fig.7900

Demount the hinges and remove the door. Remove the upper hinge first.

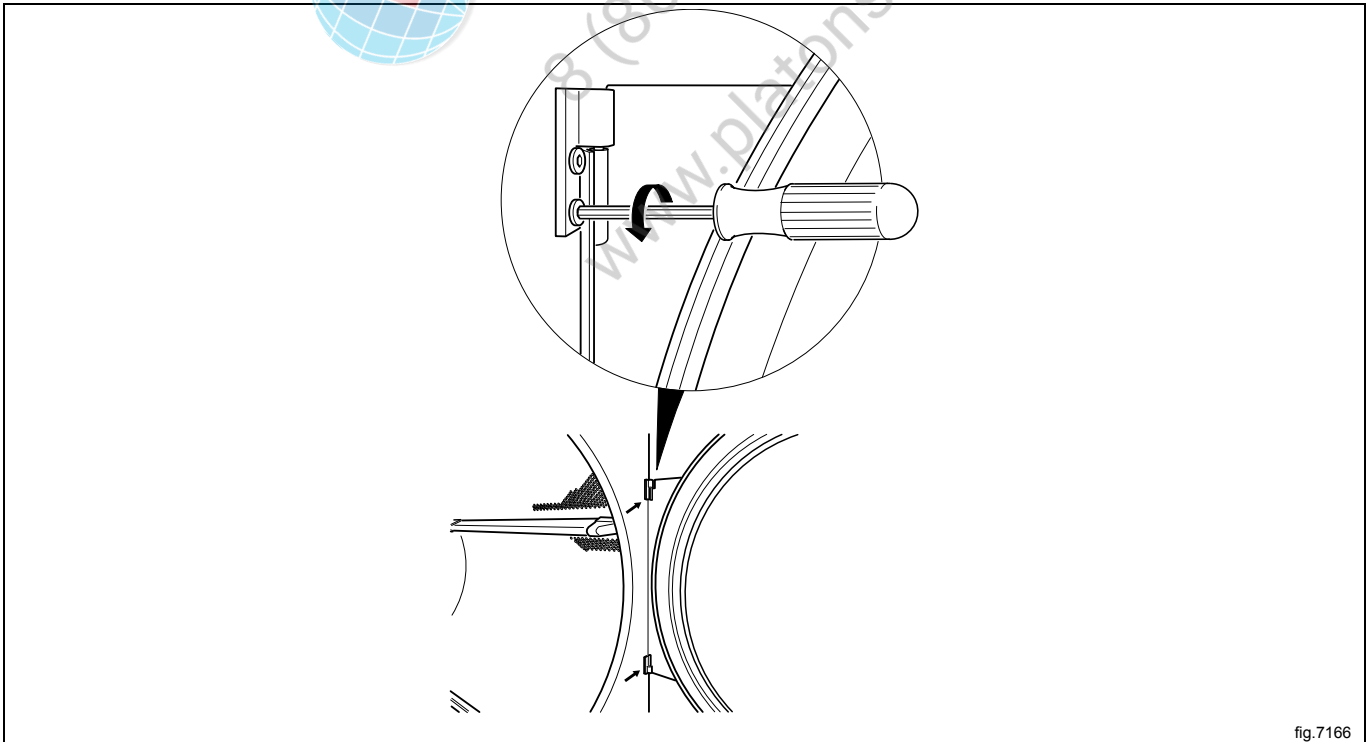

fig.7166

Remove the screws on the front panel and carefully loosen the panel. Push the door switch cable down through the hole in order to access the cable and then disconnect the cable. Remove the panel.

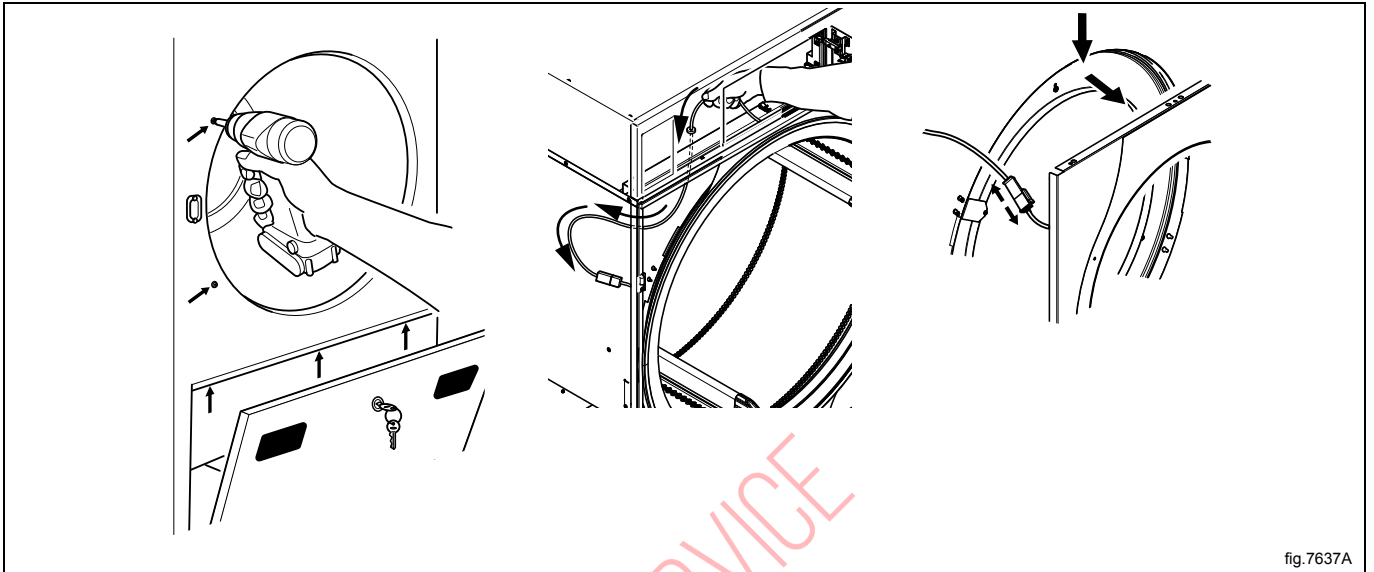

fig.7637A

Loosen the screws and remove the brackets.

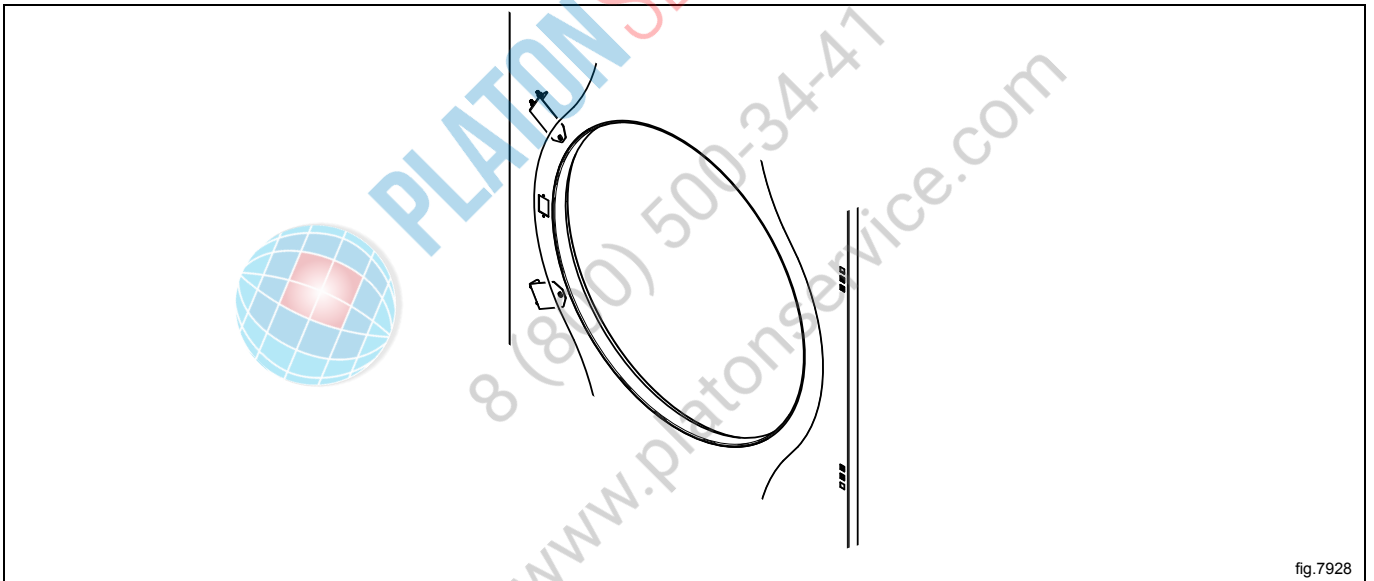
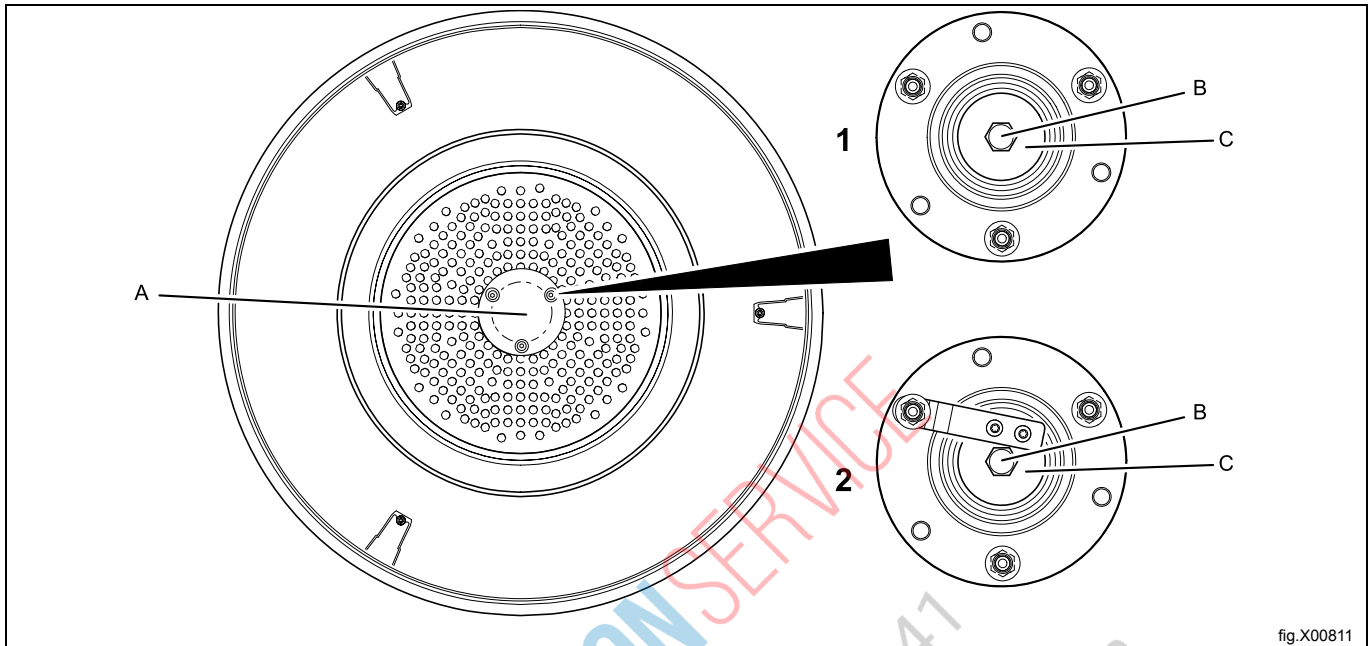

fig.7928

Remove the screws and the bearing house (A).

1. Shows a machine without RMC. Remove the bolt (B) and the washer (C).
2. Shows a machine with RMC. Loosen the screw and pull the RMC flange to the side in order to remove the bolt (B) and the washer (C).



Demount the RMC with arm.

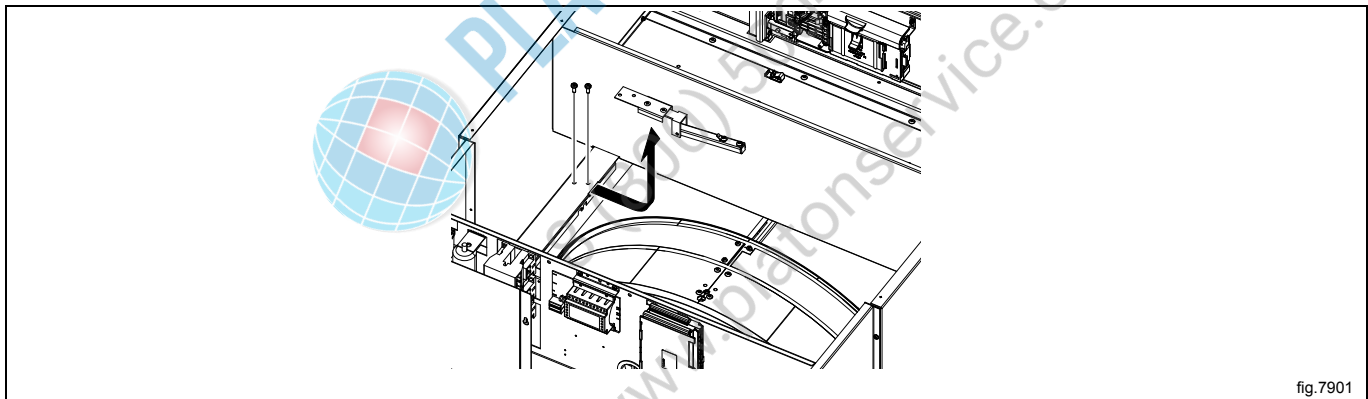

Carefully lift out the drum.

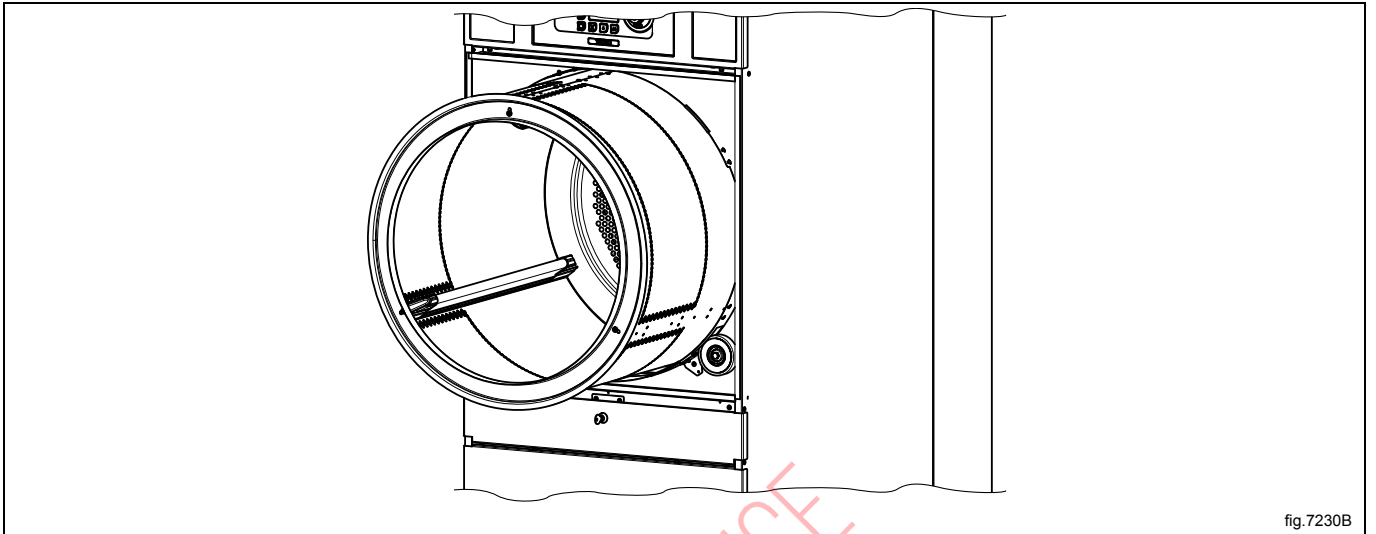

fig.7230B

Remove the screws and remove the outer sealing plate.

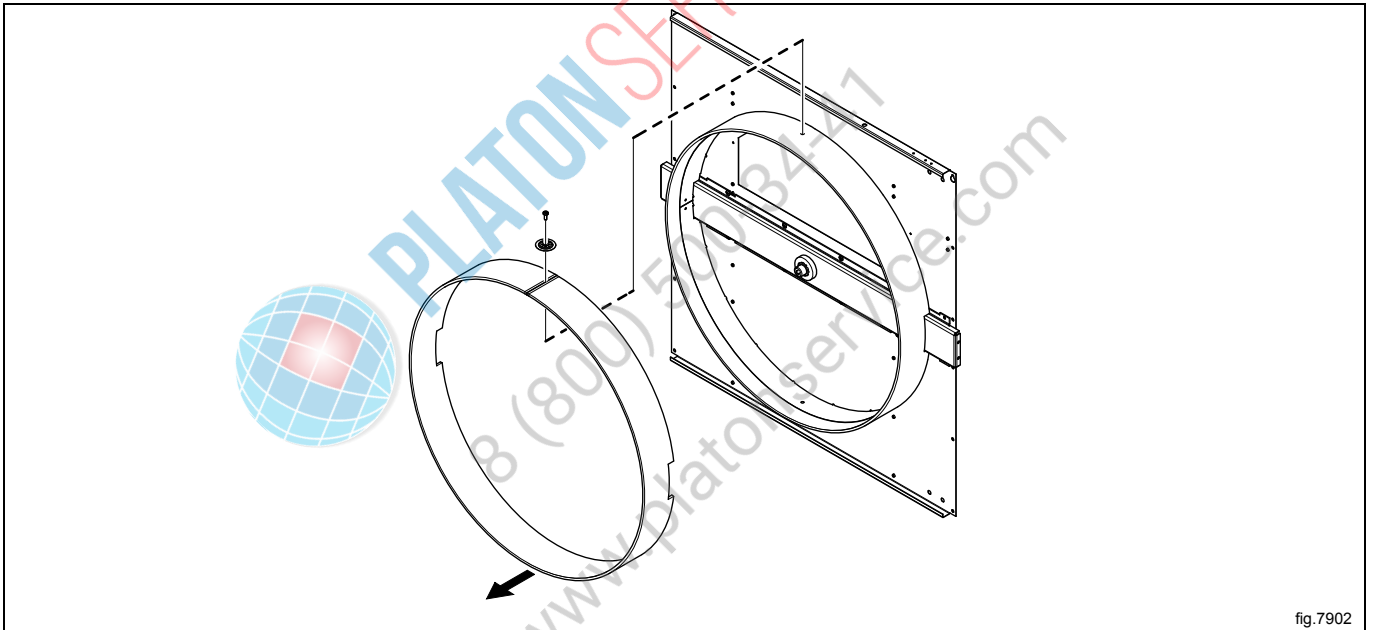

fig.7902

Cut loose the rear sealing from the inner sealing plate.

Put glue on the inner sealing plate and fasten the new rear sealing on the inner sealing plate. The rough side shall be fastened to the glue.

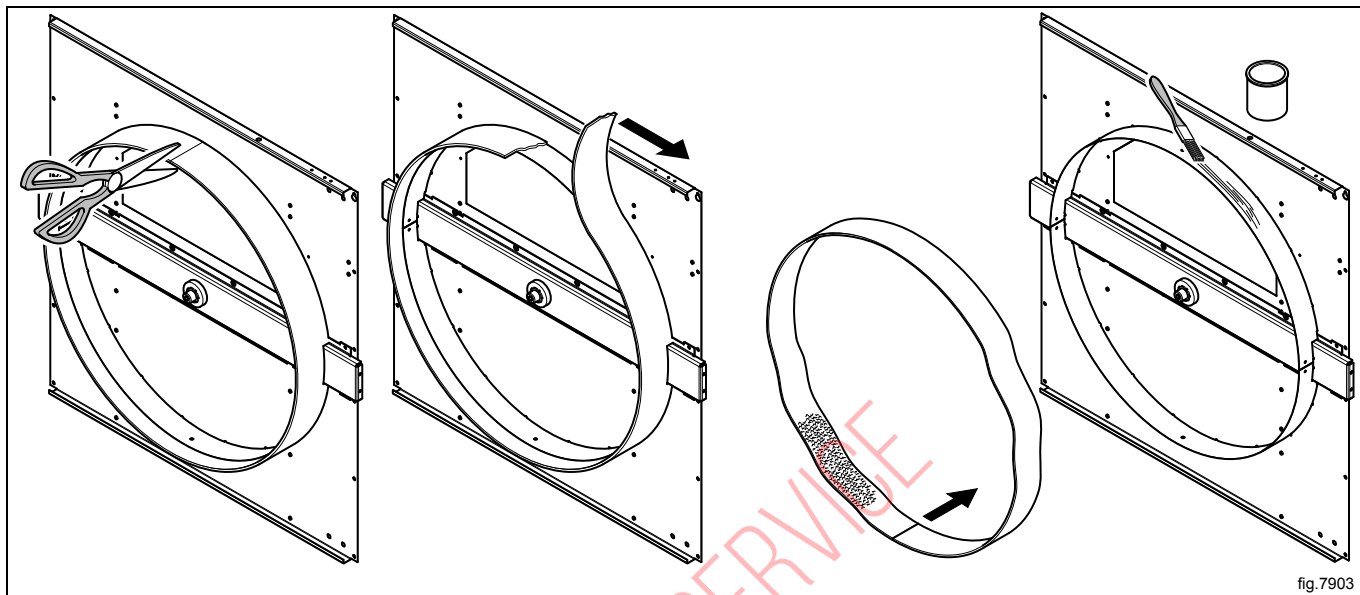

fig.7903

Remount the outer sealing plate and fasten the screws.

Remount the RMC with arm.

Fasten the bolt and the washer and remount the bearing house. Use tightening torque $20 \text{ Nm} \pm 3 \text{ Nm}$.

On machines with RMC; pull the RMC flange back in position and tighten the screw. Use tightening torque $5 \text{ Nm} \pm 0.5 \text{ Nm}$.

Fasten the belt and make sure the belt is in position. Fasten the belt tensioner.

Remount the rear panel and the top panel.

Connect the door switch cable and push the cable in over the drum and pull it upwards.

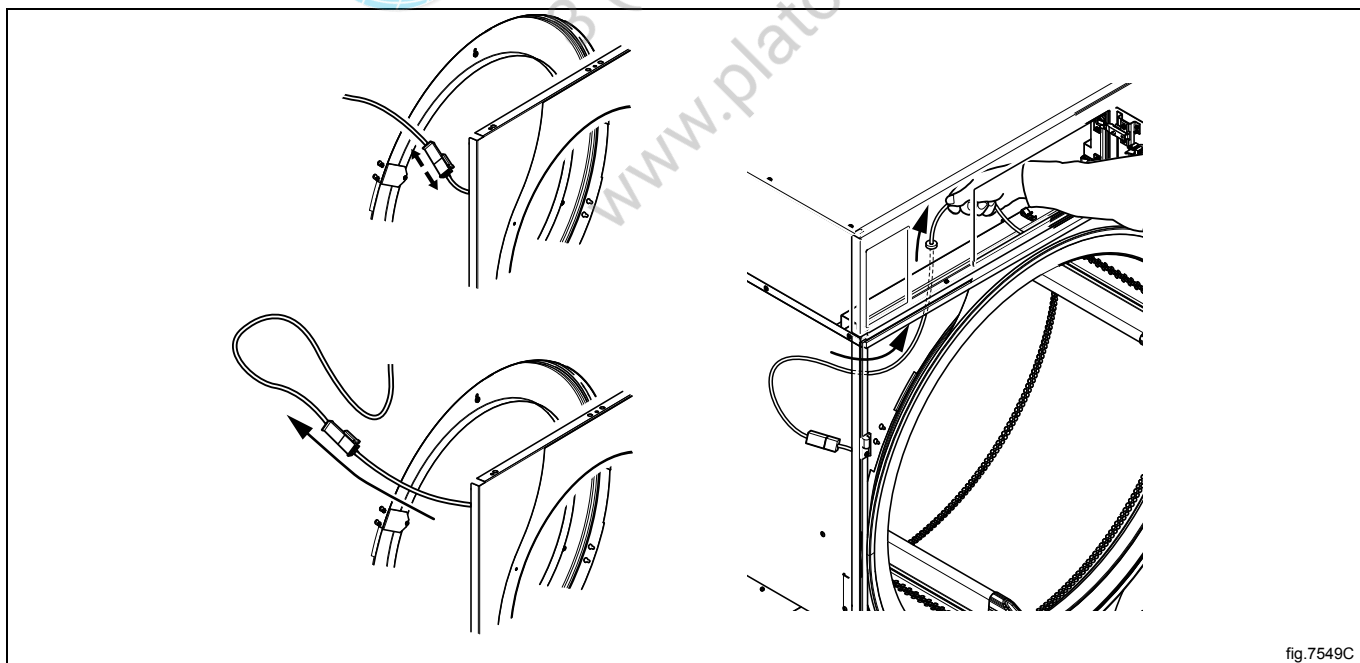

fig.7549C

Remount the front panel.



Ensure that the door switch cable does not get damaged when remounting the front panel.

Remount the door.



PLATON SERVICE

8 (800) 500-34-41

www.platonservice.com

12 Control panel

12.1 Control system

12.1.1 Description

The control system CPU is electronic and comprises a circuit board containing microprocessor, program memory, serial interface to the motor, I/O-boards etc.

The control system CPU receives its power from a separate power supply unit.

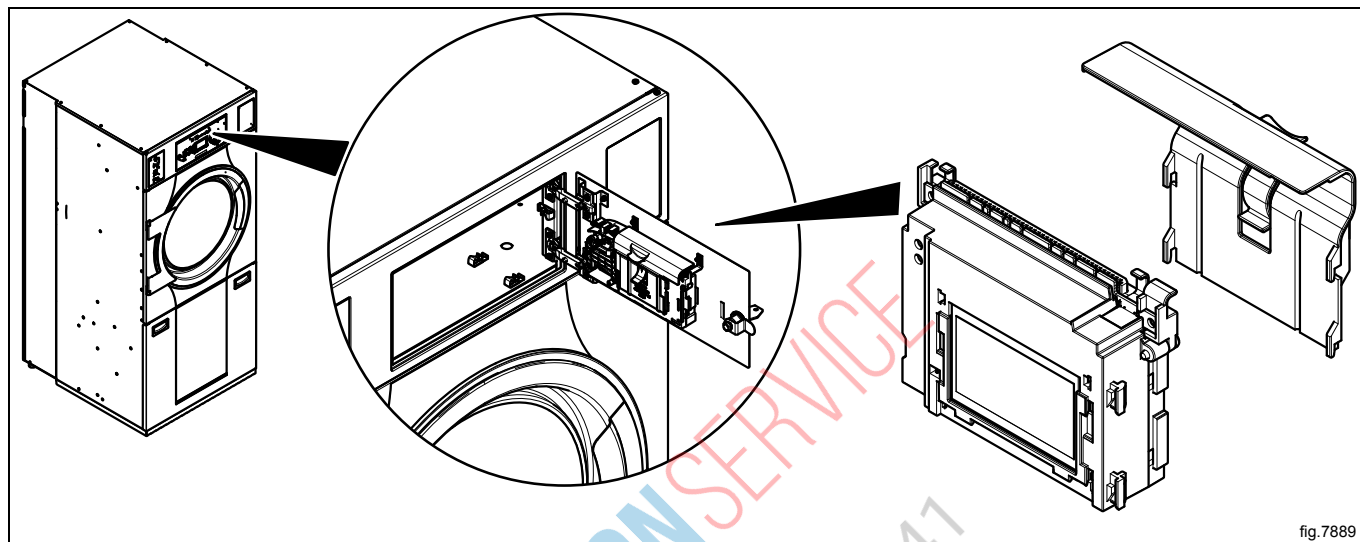

The control system receives information about inputs like temperature sensors, RMC, vacuum, door status etc, and activates outputs like drum, fan and heat control.



PLATON SERVICE
8 (800) 500-34-47
www.platonservice.com

12.1.2 Connections

The control system CPU has the following connections:

Board connector	Function
J1	M-COM = Communication, motor control
J2	D-BUS = Databus
J3	D-BUS = Databus
J4	Tacho
J5	COIN = Input, coin meter
J6	EMERG = Input, stop button
J7	FREE = Free program (key switch)
J8	RS 232 = Serial communication
J9	Control knob, pulses
J10	USB TYPE B = Connection for software/service download
J12	Display
J13	Membran switches

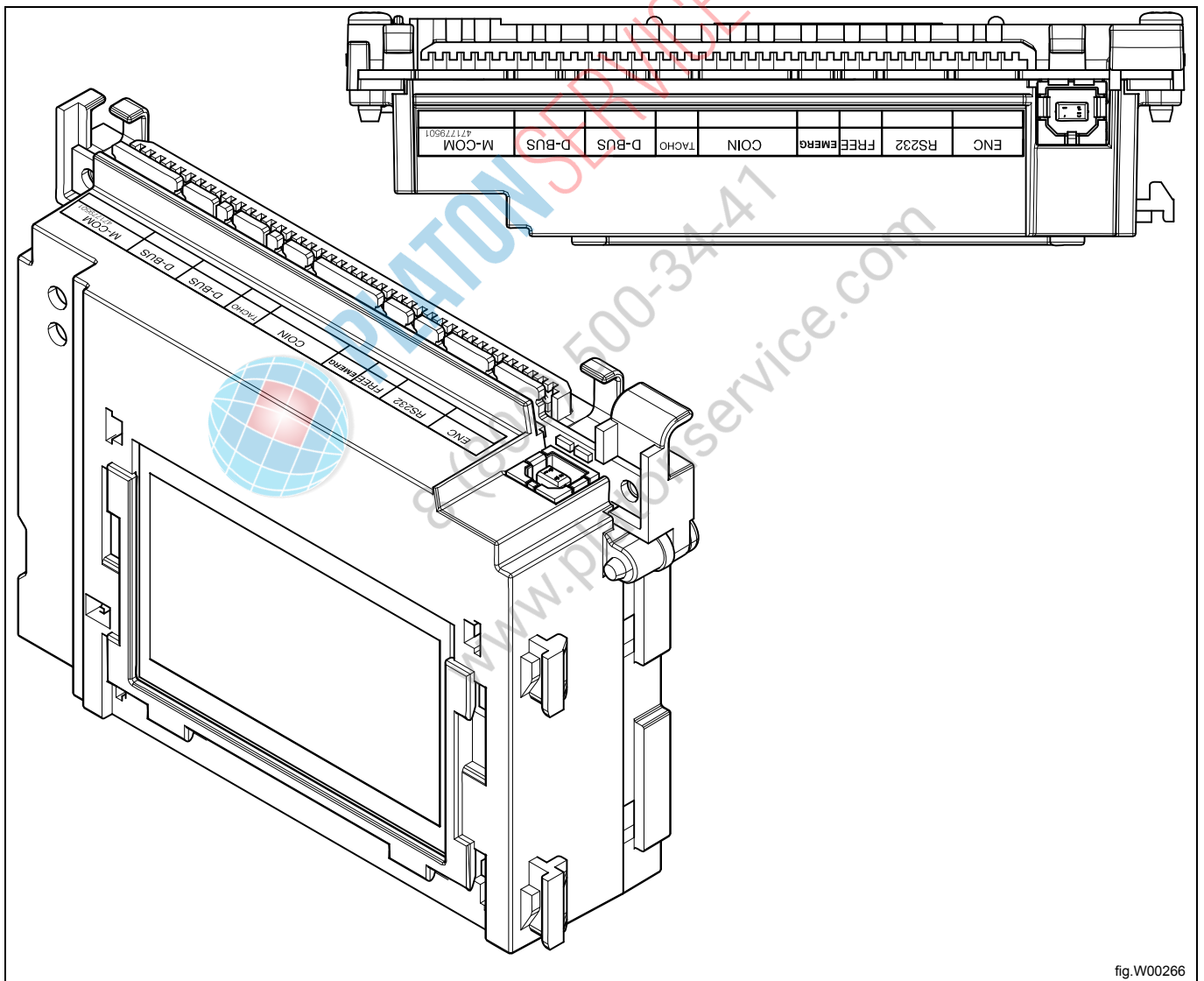

fig.W00266

12.1.3 Replacement of control system CPU

Disconnect the power to the machine.

Demount the control knob

Insert a screwdriver in the upper hole.

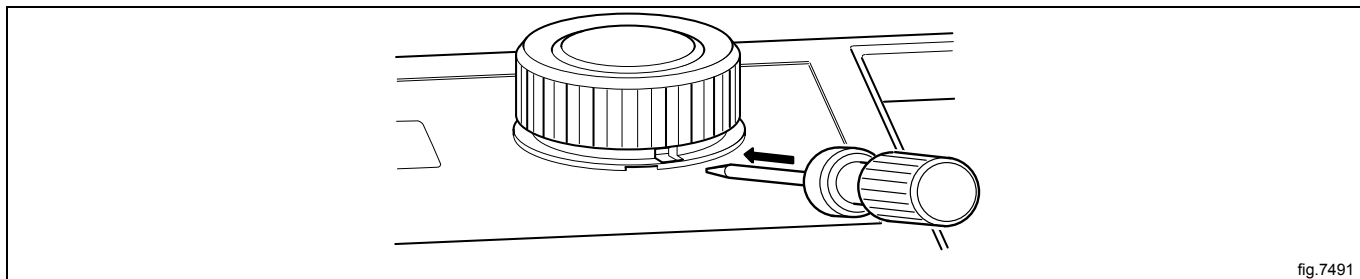

fig.7491

Gently push the screwdriver inwards and turn the control knob counter-clockwise until the screwdriver goes further in.

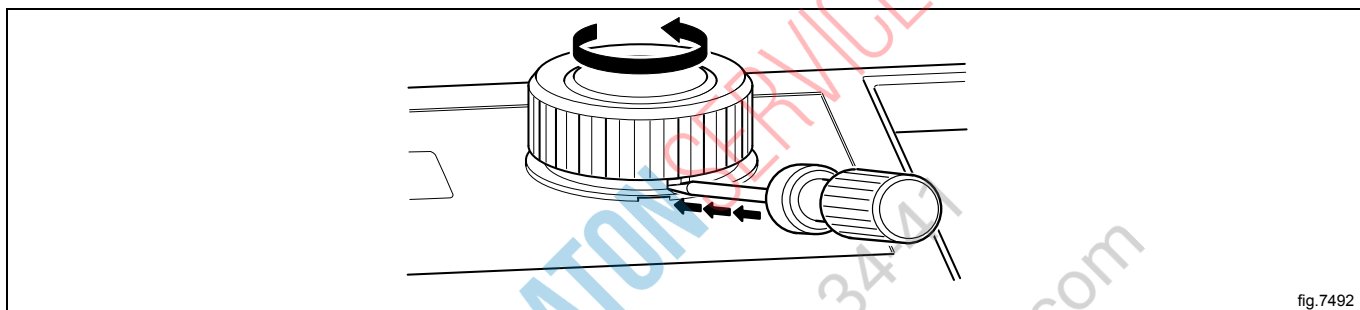

fig.7492

Continue turning a quarter of a turn until it is possible to remove the control knob.

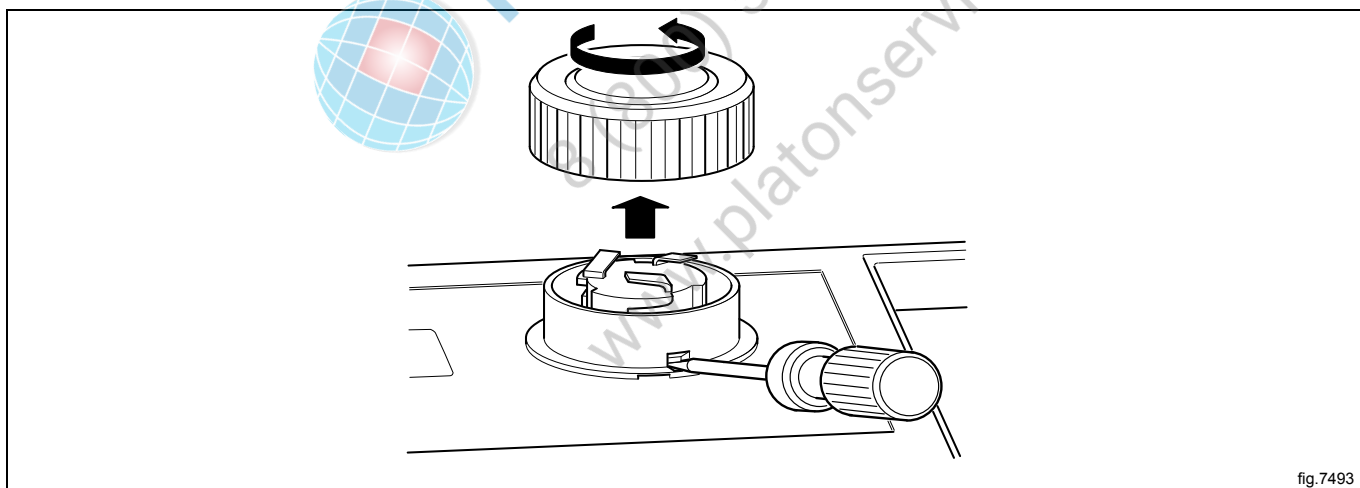

fig.7493

Demount the cover ring

When the control knob is removed, insert the screwdriver in the lower hole and press gently. Turn the cover ring counter-clockwise until it is possible to remove the cover ring.

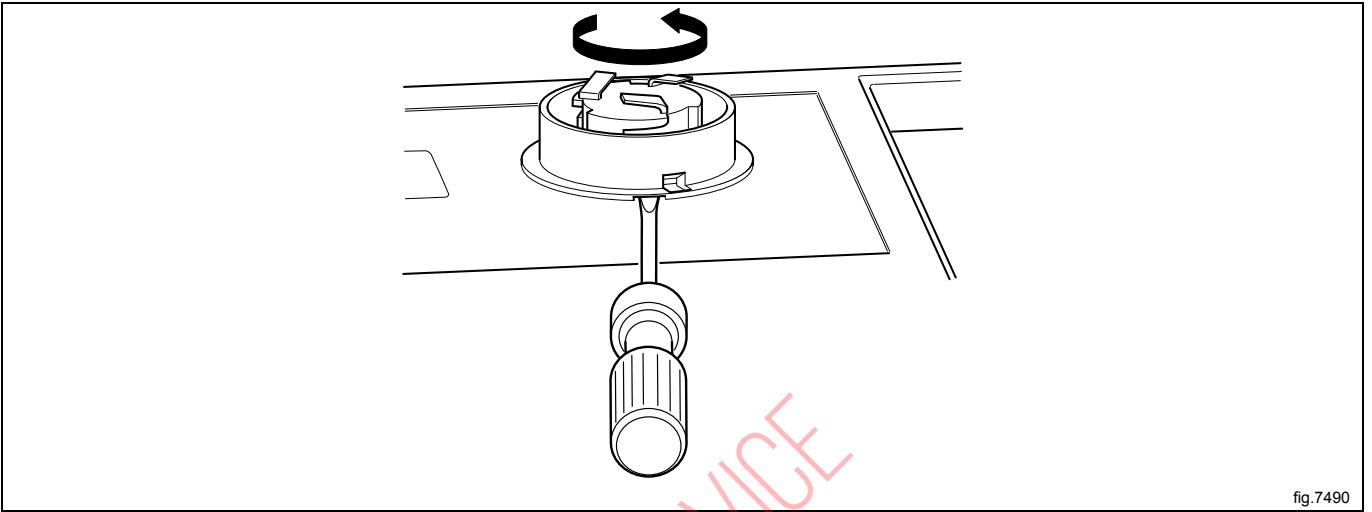

fig.7490

Demount the control system CPU

Open the door to the control system CPU.
Demount the cover to the control system CPU and disconnect the cables.

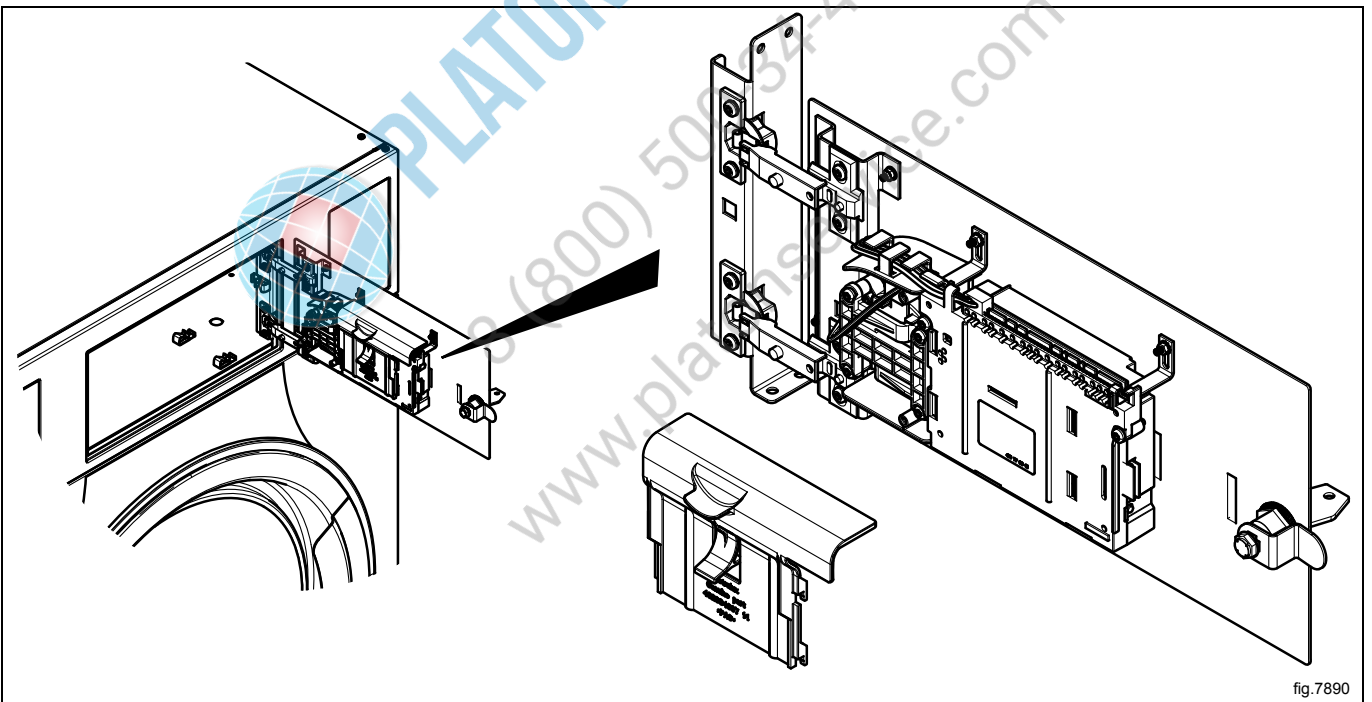

fig.7890

Loosen the nuts holding the control system CPU onto the panel.

Demount the control system CPU by first pushing the control system CPU upwards until it stops and then remove it.

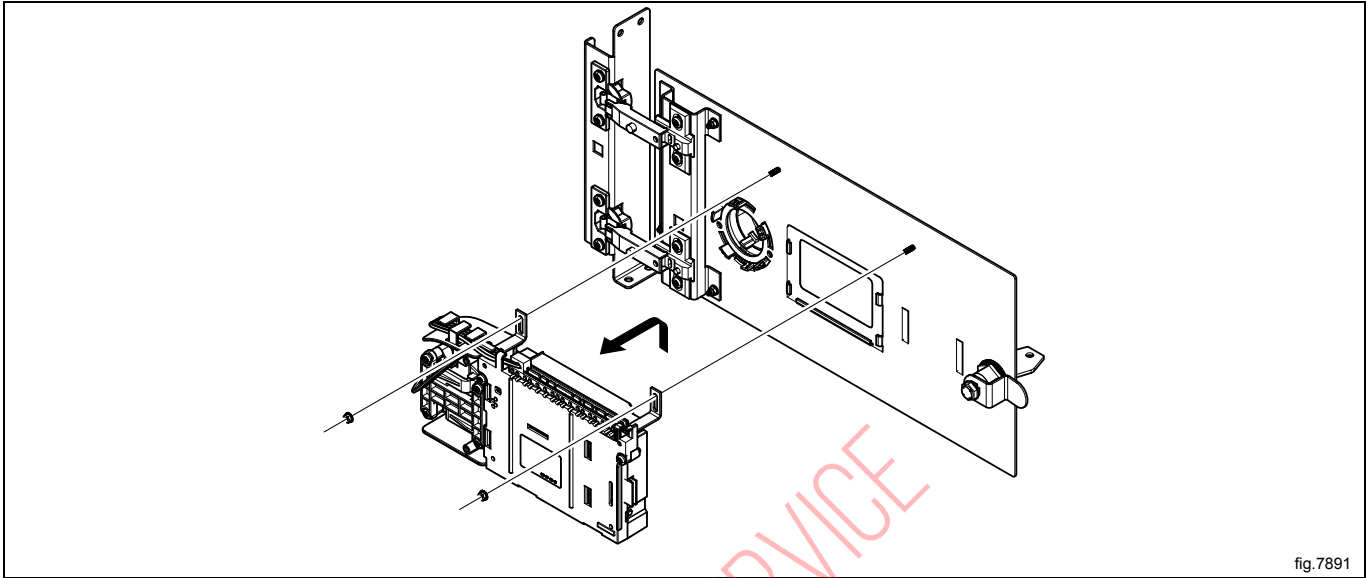

fig.7891

Demount the control knob unit from the control system CPU by unscrewing the screw (A) a bit (4–5 mm) until the control knob unit loosens.

Demount the two grounding brackets (B).

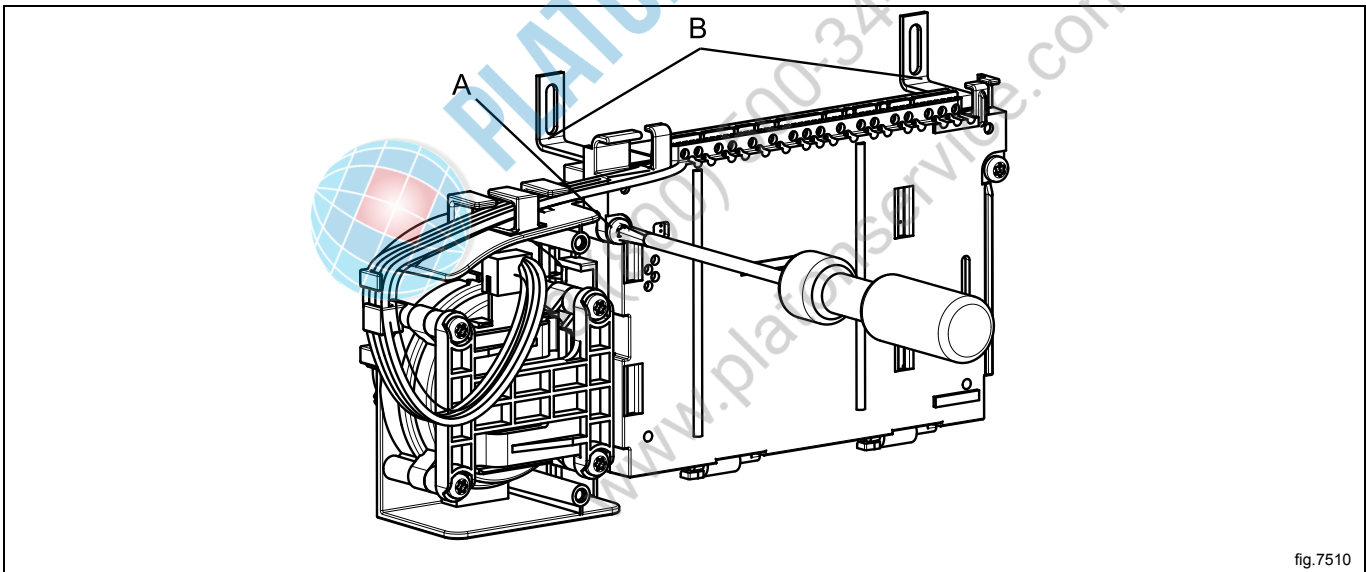

fig.7510

Mount the new control system CPU

Start by mounting the control knob unit on the control system CPU. Fasten the screw (A).

Mount the two grounding brackets (B) on the new control system CPU.

Mount the control system CPU in upper position. Insert the control knob unit and make sure that the guide pins (D) are in position. Pull the control system CPU downwards. Fasten the nuts to the panel.

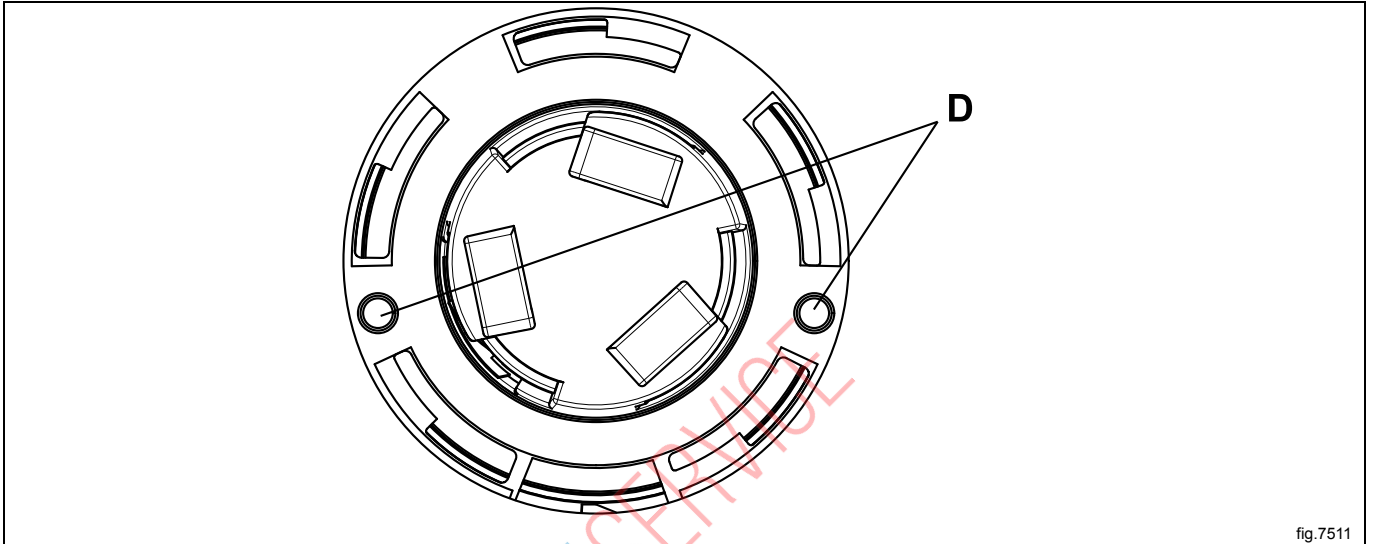

Connect the cables and remount the cover to the control system CPU.

Mount the cover ring and the control knob

Mount the cover ring and rotate it clockwise until it is in position.

Rotate the inner knob until the locking device is pointing downwards.

Insert the screwdriver and press the locking device.

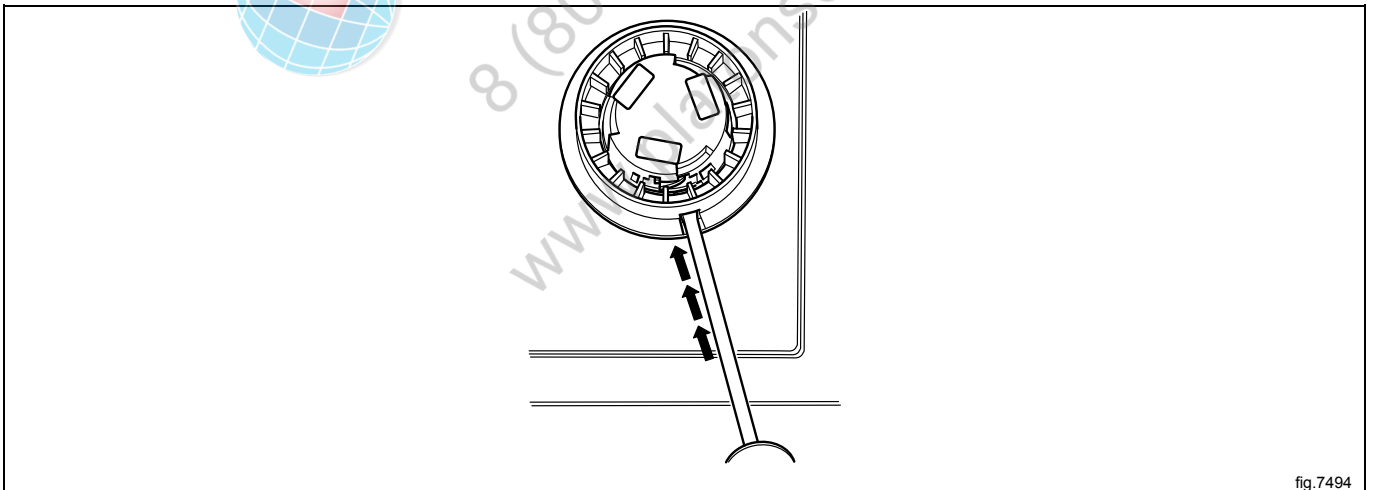

Mount the control knob on the inner knob. Continue to press with the screwdriver and turn the control knob clockwise until it stops when it is in position.

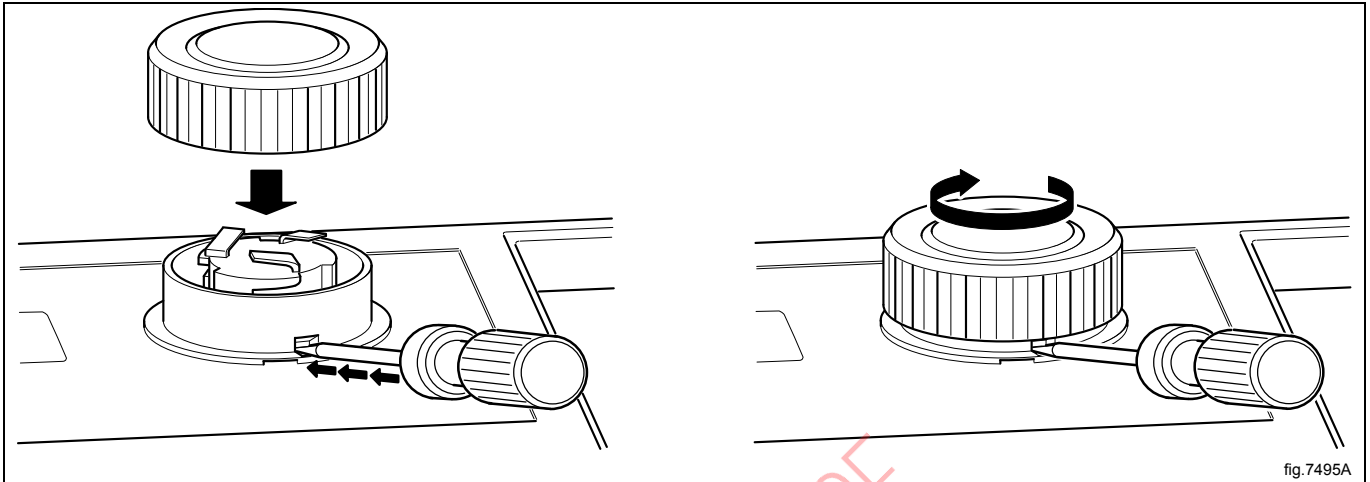

fig.7495A



PLATON SERVICE
8 (800) 500-34-47
www.platonservice.com

12.2 Control knob

12.2.1 Replacement of control knob

Disconnect the power to the machine.

Insert a screwdriver in the upper hole.

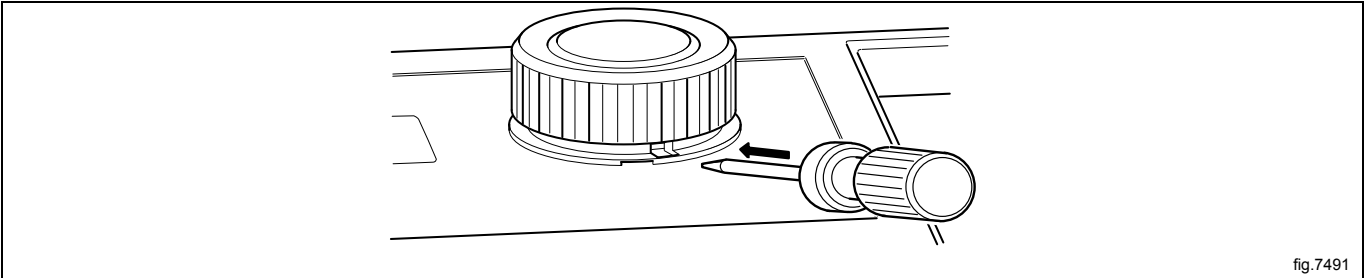

fig.7491

Gently push the screwdriver inwards and turn the control knob counter-clockwise until the screwdriver goes further in.

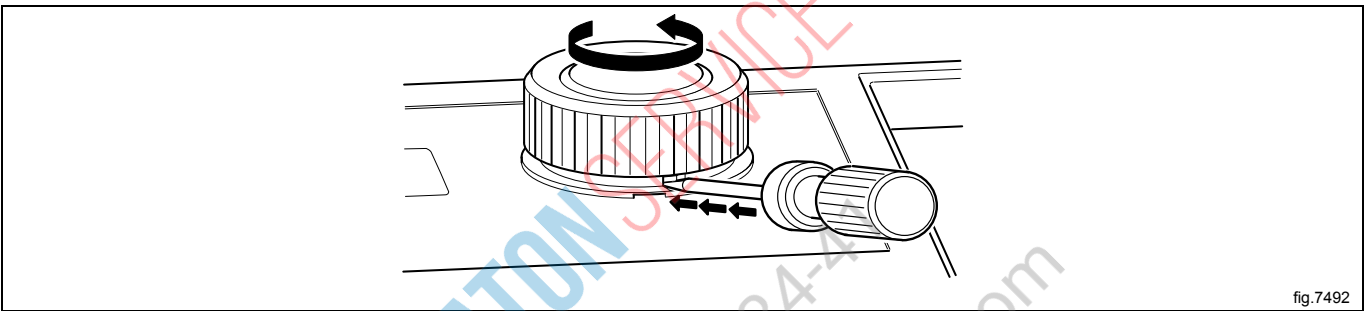

fig.7492

Continue turning a quarter of a turn until it is possible to remove the control knob.

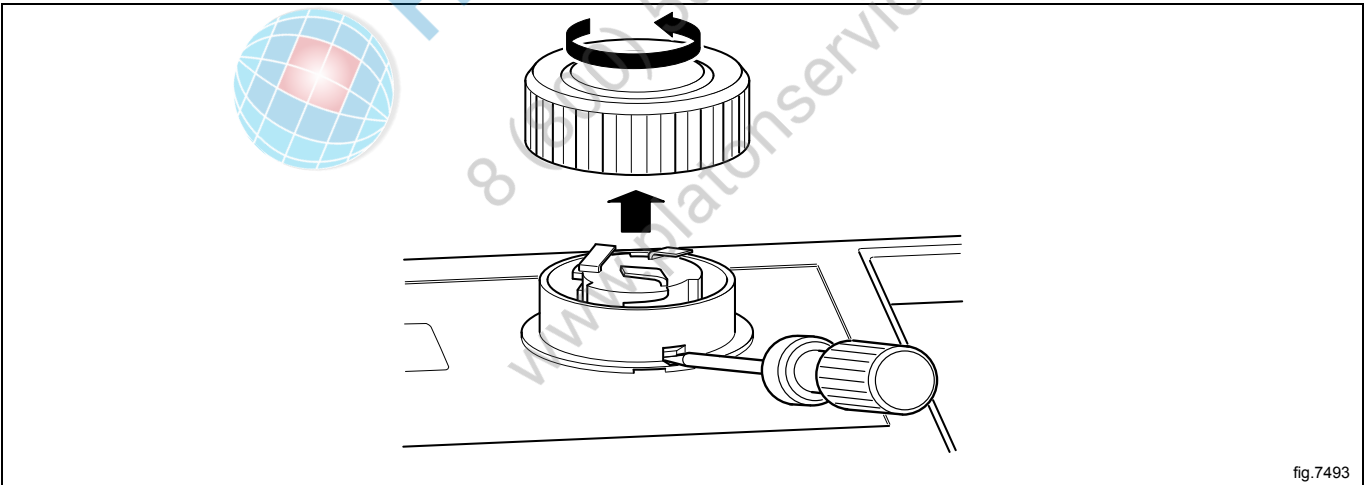

fig.7493

Cover ring

When the control knob is removed, insert the screwdriver in the lower hole and press gently. Turn the cover ring counter-clockwise until it is possible to remove the cover ring.

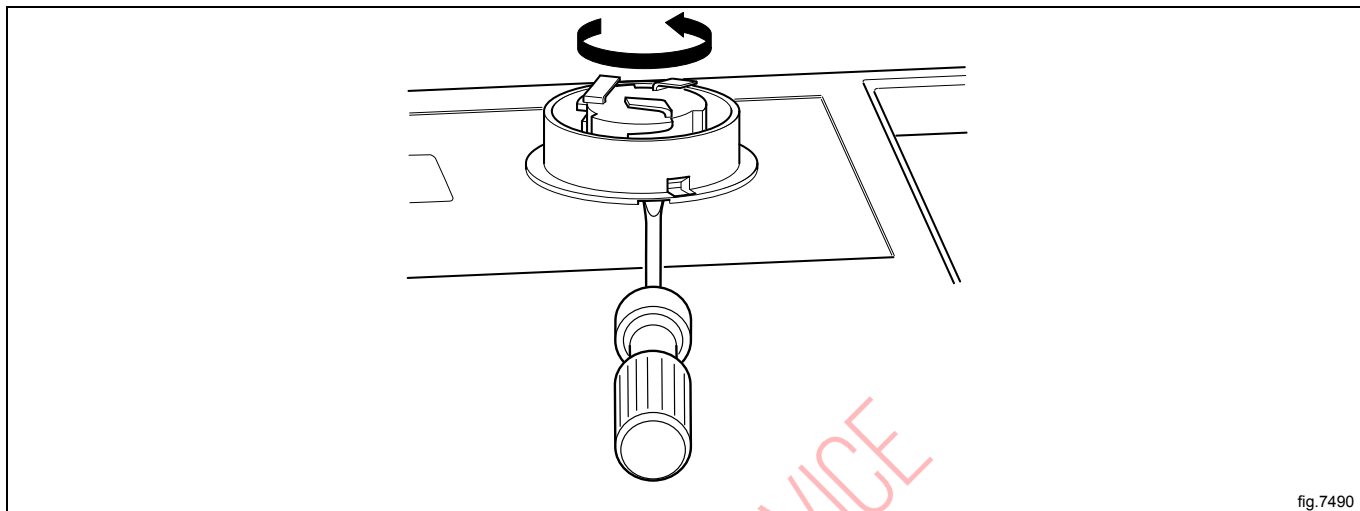

fig.7490

Mount the new cover ring and rotate it clockwise until it is in position.

Rotate the inner knob until the locking device is pointing downwards. Insert the screwdriver and press the locking device.

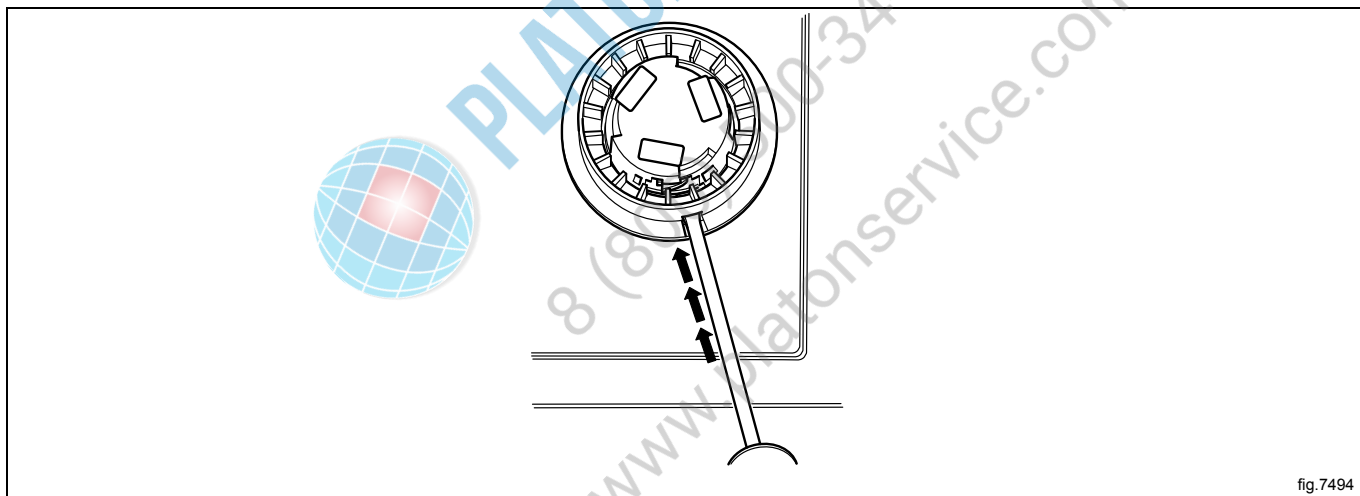

fig.7494

Mount the new control knob on the inner knob. Continue to press with the screwdriver and turn the control knob clockwise until it stops when it is in position.

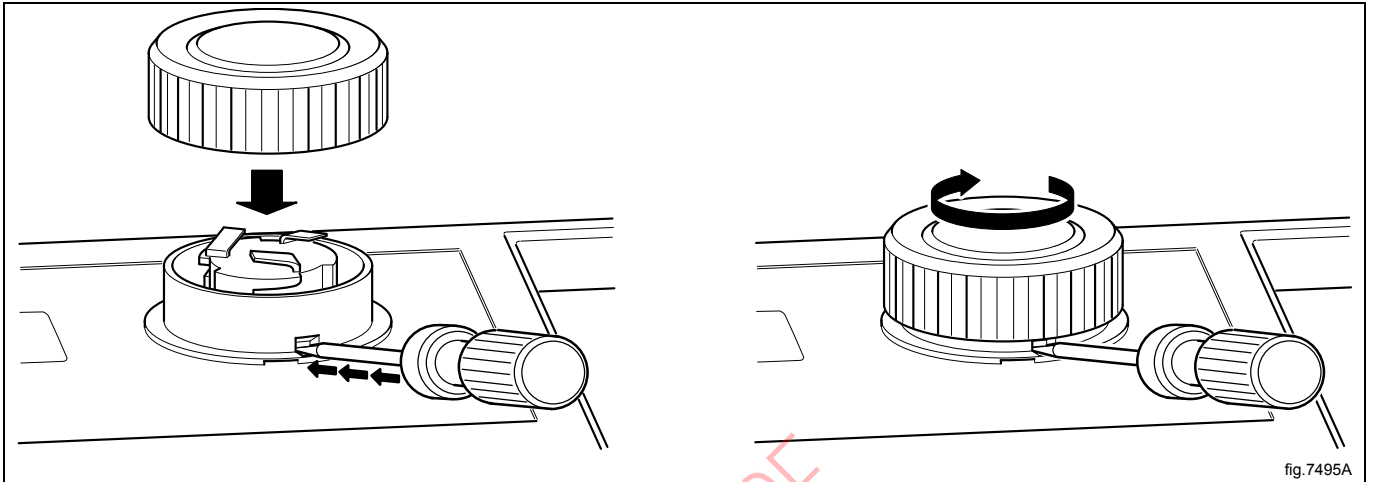

fig.7495A



PLATON SERVICE
8 (800) 500-34-47
www.platonservice.com

13 I/O modules

13.1 General

The machine can be equipped with either one or two I/O modules:

- I/O module type 81 is always installed in the machine at delivery. It controls internal machine functions and outputs to heating, motors etc.
- I/O module type 2 is installed as an option. It controls the external functions and inputs from payment and booking systems etc.

The functionality of I/O module inputs and outputs is depending on the parameter software downloaded to the machine's program device. The function options for the I/O modules are indicated by a letter in the program designation for each module.

Machine fitted with two I/O modules

6G82 LG1 EL T5250 81O 22J

81O = Function options I/O module type 81 (internal functions).

22J = Function options I/O module type 2 (external functions).

Machine fitted with one I/O module

6G82 LG1 EL T5250 81O 22j

81O = Function options I/O module type 81 (internal functions).

22j = The letter that appears in lower case means that the machine is not fitted with I/O module type 2 but the downloaded parameter software is I/O module type 2 enabled.



PLATON SERVICE

8 (800) 500-34-41

www.platonservice.com

Location

The parameter software installed in the machine's program device on delivery is specified at the front and back of the machine.

Using this article number, you can find the program designation and thereby identify I/O module function options on the web.

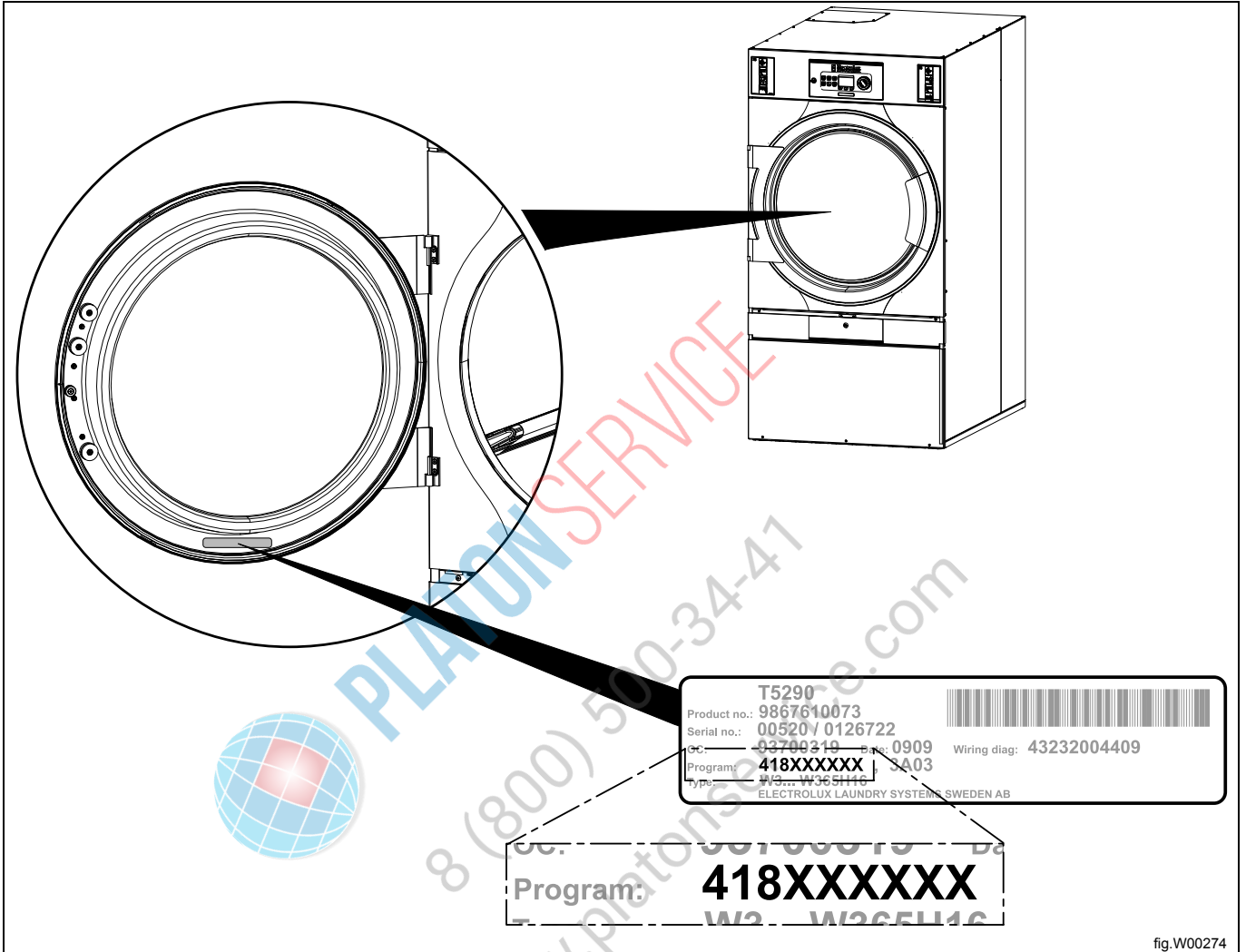

fig.W00274

13.2 Replacement of I/O module

I/O module type 8 and I/O module type 2 are installed in the same way. If the machine has I/O module type 2, it is located on I/O module type 8. The illustration shows replacement of I/O module type 8.

Disconnect the power to the machine.

Demount the rear panel.

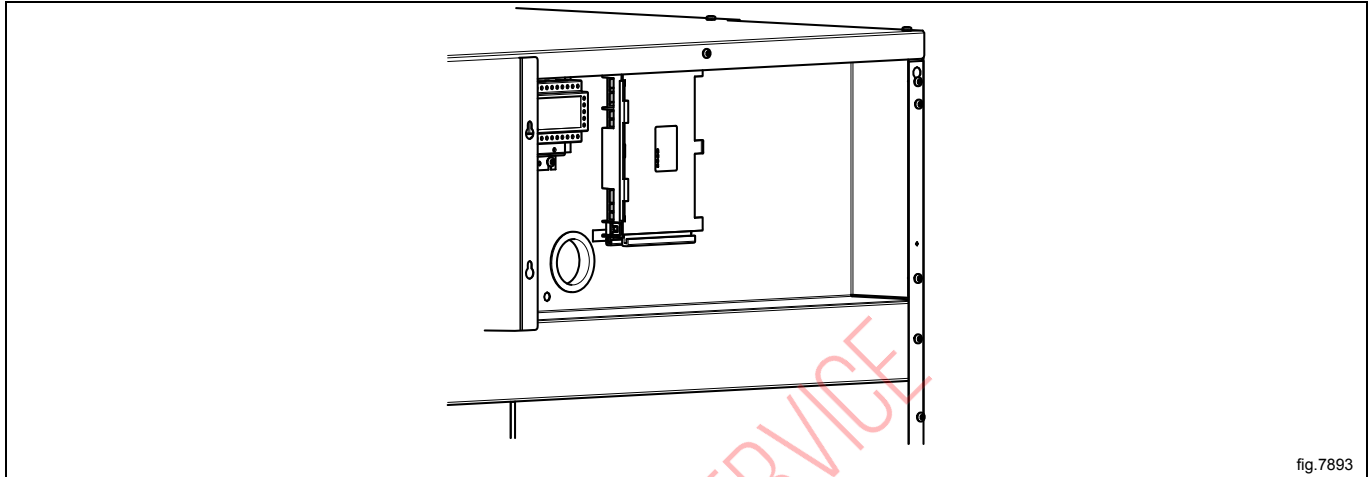

fig.7893

Remove the electrical connections on the module. (Note the position of the connections).

Remove the module by lifting it towards you and up a bit and then pushing it to the left.

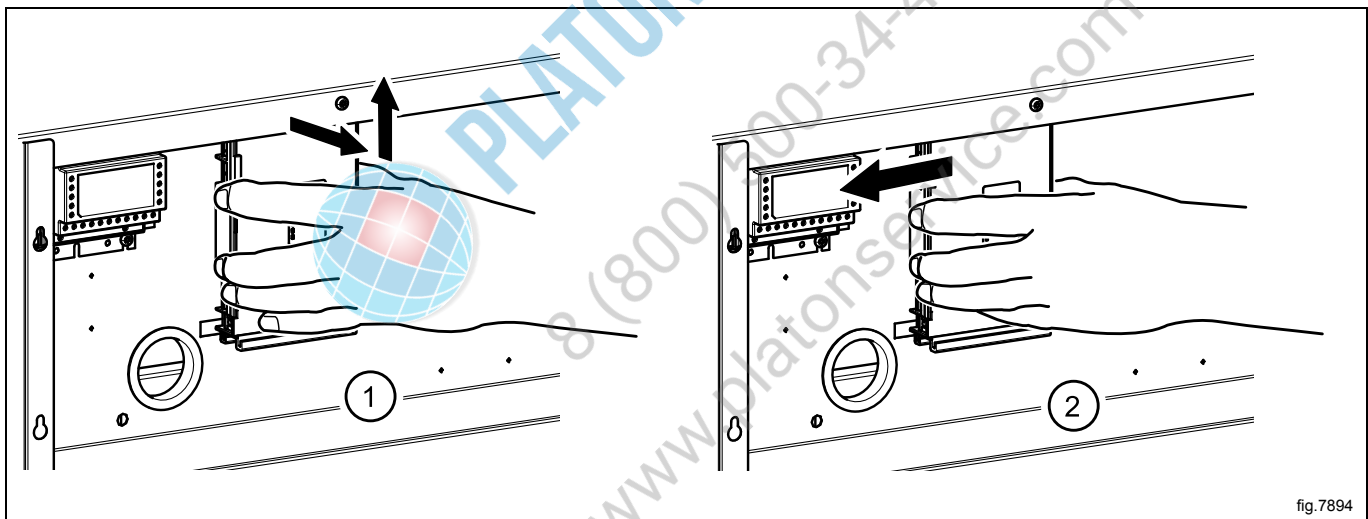

fig.7894

Insert the new module and make sure it is in position.

Connect the electrical connections in the same way as before.

If both I/O module type 8 and I/O module type 2 is to be replaced it is recommended to fit the modules together before mounting in the machine.

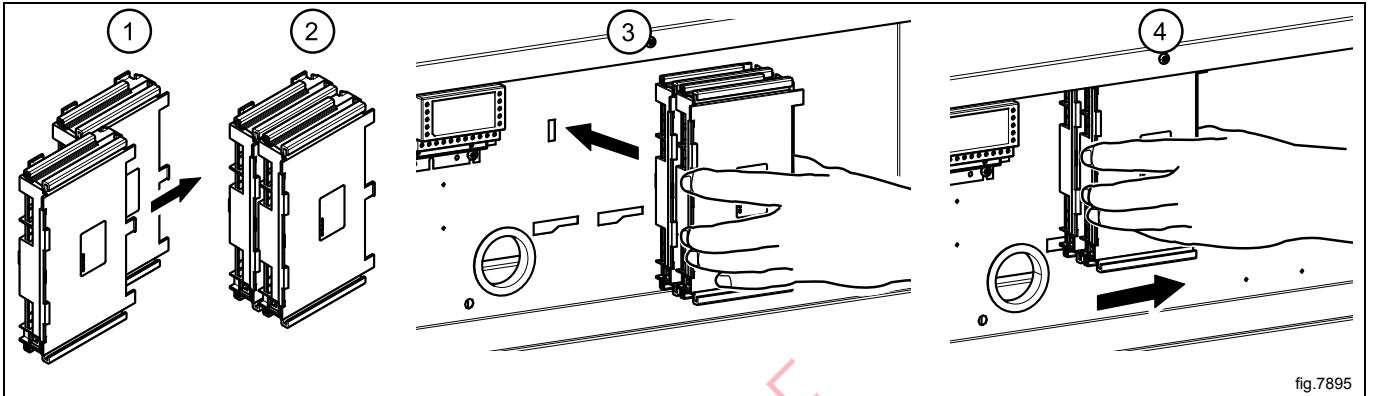

fig.7895

Remount the rear panel.

Connect the power to the machine.

13.3 External connections to I/O module type 2

Inputs

The signal level may be 5 - 24V DC/AC or 100 - 240V AC. At 5 - 24V, the signal reference must be connected to 3 and at 100 - 240V to 4.

Note!

Do not mix potentials on the inputs.

Connecting excessive voltage (> 24V) to connection 3 may damage the I/O modules.

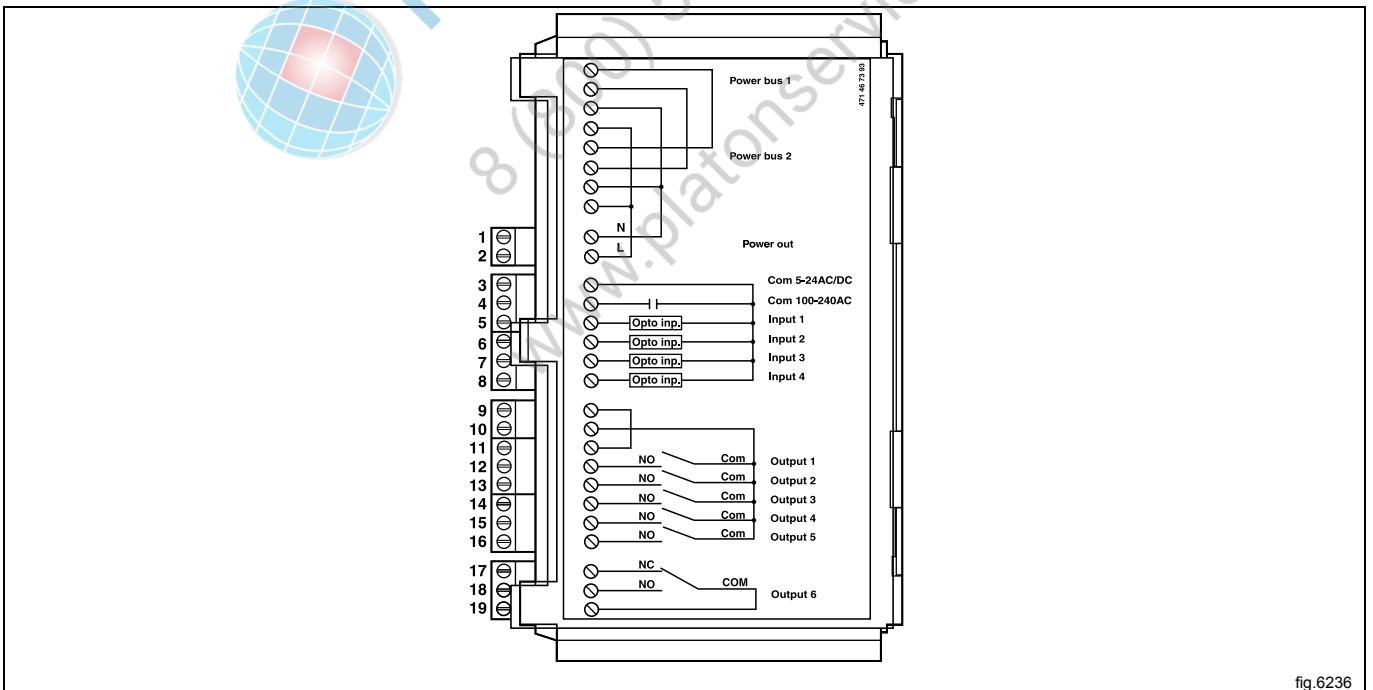

fig.6236

13.4 Circuit diagram of function options for I/O module type 2

13.4.1 Central payment (2J)

To start the machine from a central payment system, the payment system must transmit a start pulse 300–3000 ms (500 ms is recommended) with a minimum pause of 300 ms (500 ms is recommended) between two pulses. The start pulse can be either 230V or 24V. In order to receive a feedback signal once the machine has started, 230V or 24V must be connected to connection 19. The feedback signal on connection 18 remains active (high) during the entire program.

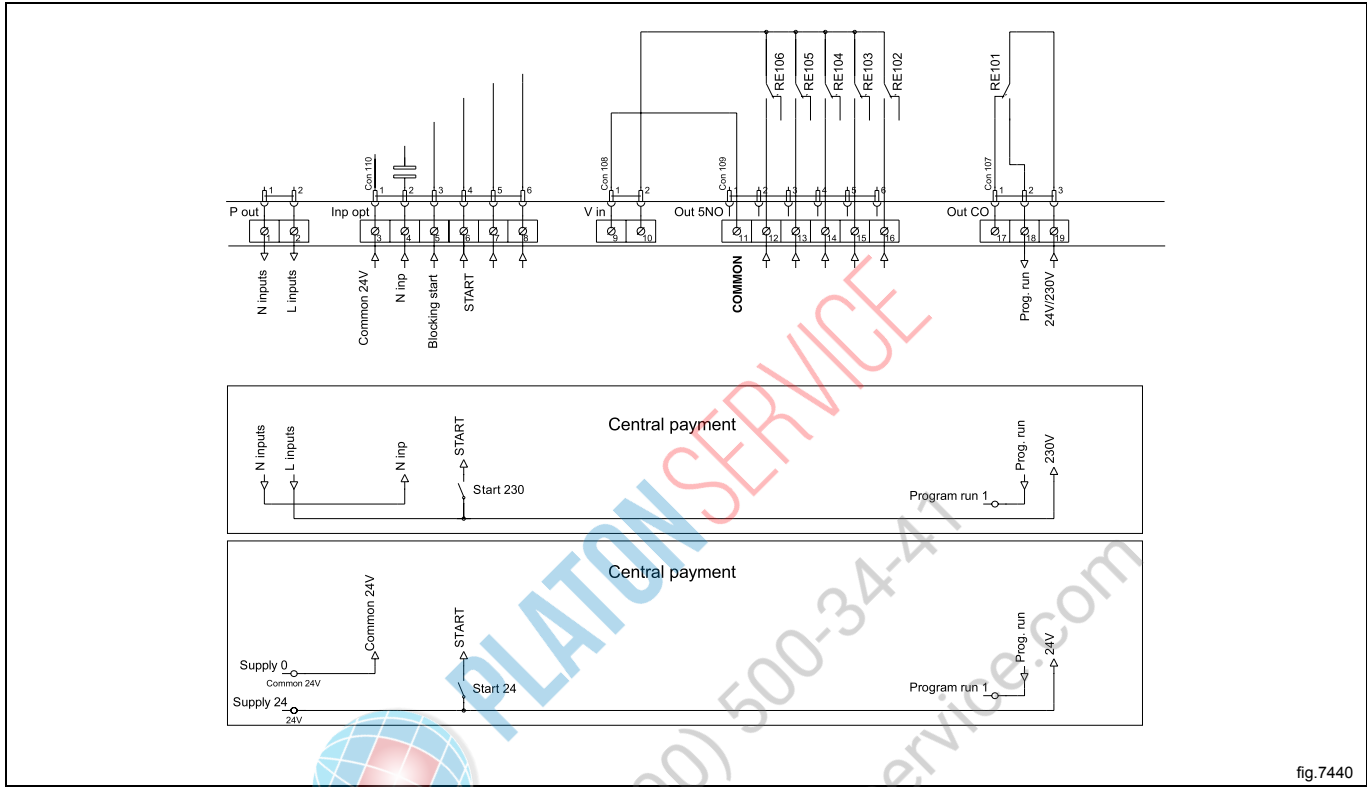

fig.7440

13.4.2 Central payment (2J)

The central payment or booking system shall transmit an active (high) signal to the machine once permission has been granted to start the machine. The signal must remain active (high) during drying. When the signal gets inactive (low) the machine will abort ongoing program and enter cooling. The signal can be either 230V or 24V. In order to receive a feedback signal once the machine has started, 230V or 24V must be connected to connection 19. The feedback signal remains active (high) during the entire program.

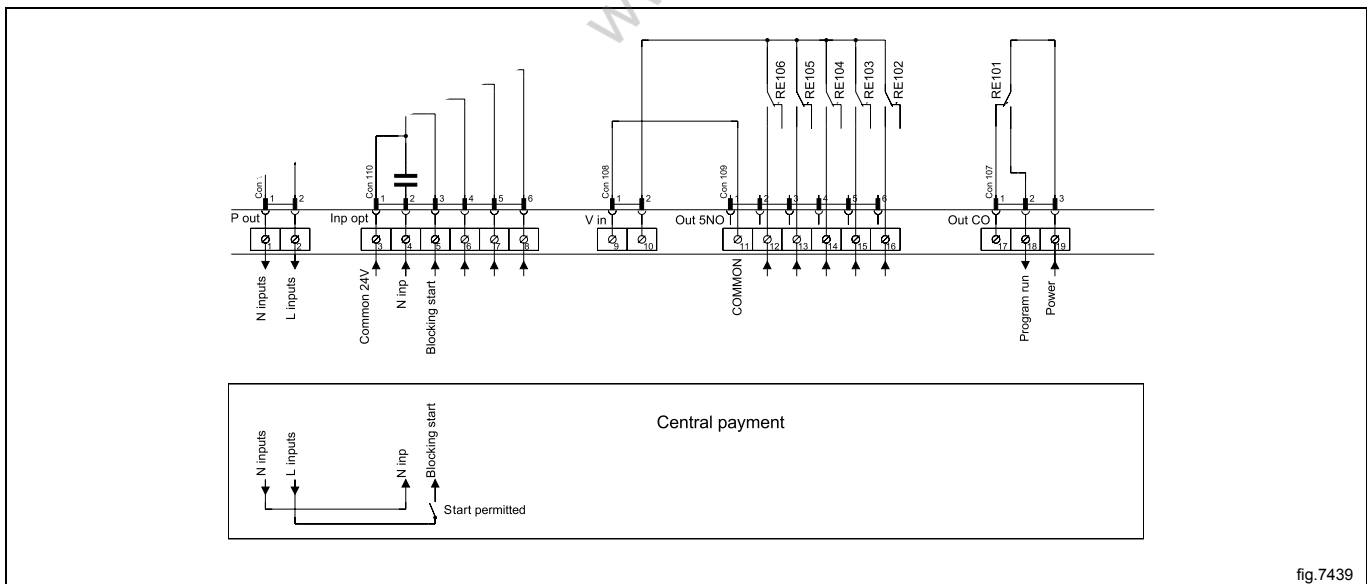

fig.7439

13.4.3 External coin meter/Central payment (2K)

The signal received from external coin meters must be a pulse between 300–3000 ms (500 ms is recommended) with a minimum pause of 300 ms (500 ms is recommended) between two pulses.

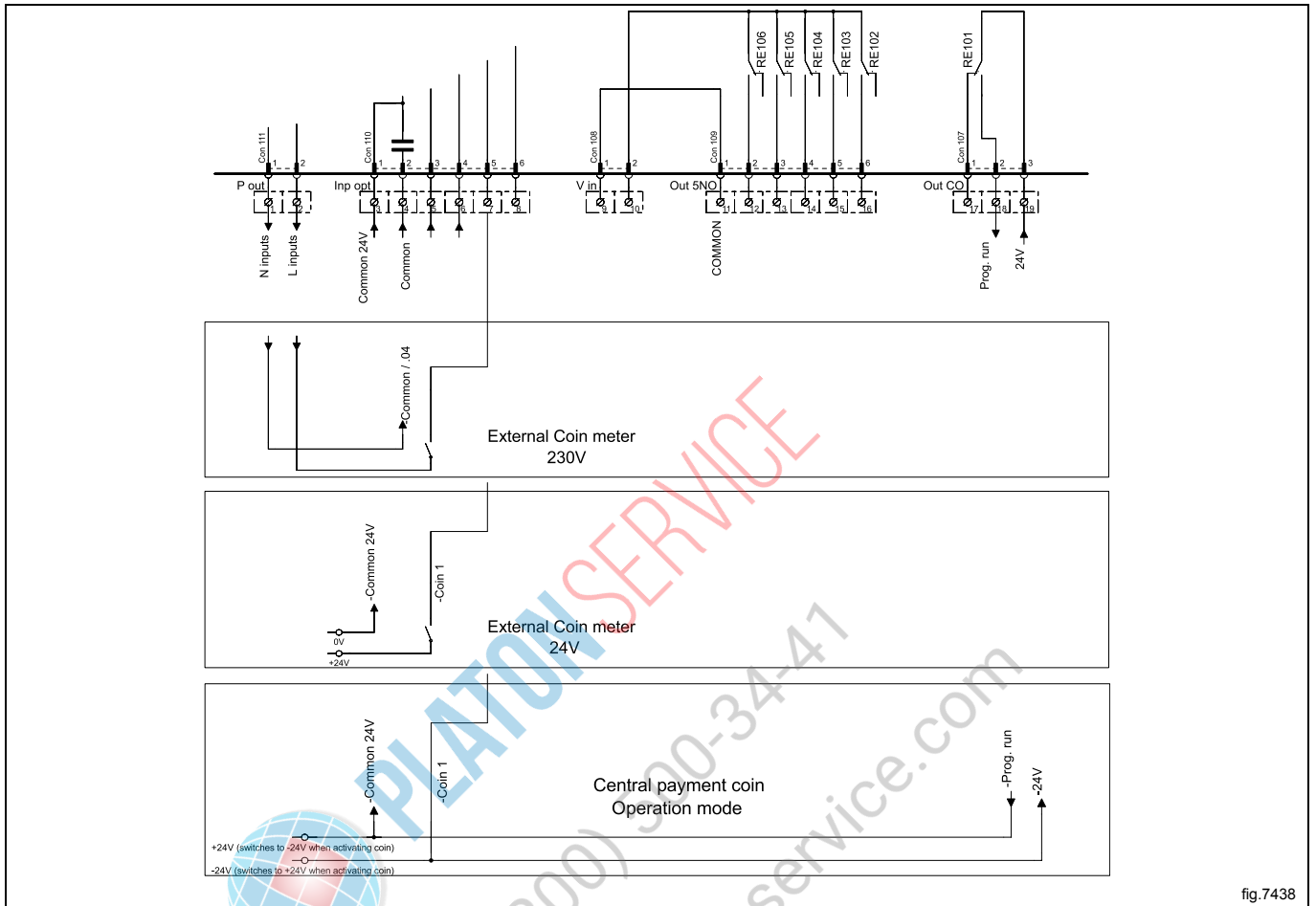

fig.7438

13.4.4 Price reduction (2K)

By maintaining an activated (high) signal on connection 5 ("Price red"), the price of the program can be reduced. This function has a number of uses, including providing reductions during a specific period of the day. Whilst the signal remains active (high), the price of the program is reduced (or the time is increased on time programs), by the percentage entered in the price programming menu.

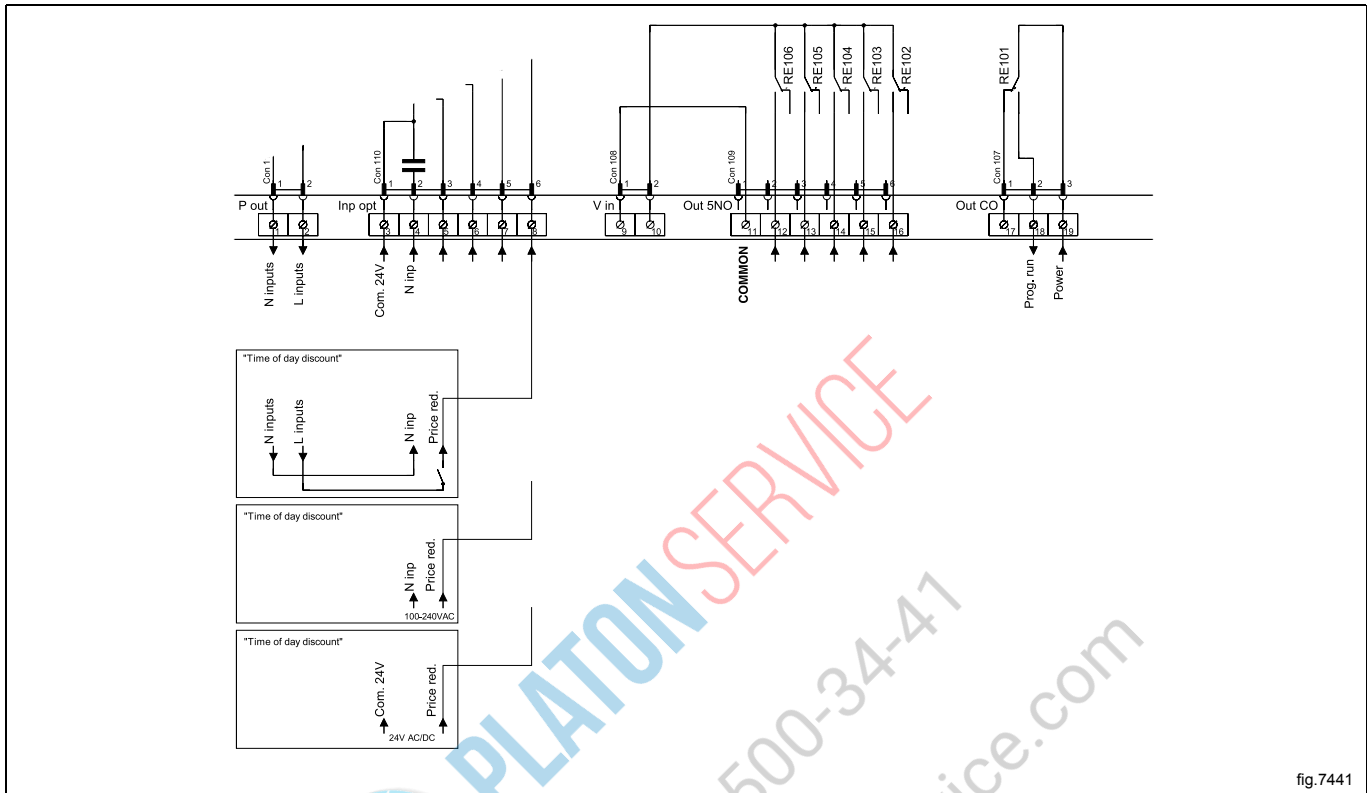

fig.7441



8 (800) 500-34-47

www.platonservice.com

14 Troubleshooting

14.1 General

The troubleshooting section is used to trace errors in the machine to a defective component or unit.

There is a memory in the control system that will save the selected program for 10 minutes in the case of power failure. The machine will restart in pause mode if the power is turned on again within this time. For very short power failure (less than 10 seconds) the machine will restart automatically.



Before resetting any error code, always verify and correct the root cause why the error is triggered.



Safety regulations

Troubleshooting may only be carried out by authorised personnel.

Take care during all work on the machine while the power is on.



Take care when measuring the motor control system since all components have a potential difference of approximately 300V in relation to protective earth and neutral. The components will contain dangerous voltages when the green LED on the motor control board is on. The motor control system will remain live for 30-60 seconds after cutting the power to the machine and the motor has stopped running.



Measurements

For information on measuring points, components and voltages, please refer to the electric schematic supplied with the machine.



PLATON SERVICE
8 (800) 500-34-41
www.platonservice.com

14.2 Error code

An error in the program or in the machine is indicated on the display by an error code and a descriptive text. The error codes are divided into different groups called "Major" comprising different error codes called "Minor". The errors will be displayed as for example 11 : 2 DOOR OPEN.

The following is a description of all Major groups followed by a description of each error code.

Error code		Text
Major	Minor	
10 MAIN COMMON	1	INTERNAL ERROR CPU TACHO
	11	REAL TIME CLOCK OUT OF ORDER
	13	INITIALIZING FAILED
	15	MACHINE STOP
	16	EMERGENCY STOP

Error code		Text
Major	Minor	
11 MAIN WASHER	1	NO WATER
	2	DOOR OPEN / LOADING DOOR OPEN
	3	DOOR LOCK FAIL / LOADING DOOR NOT LOCKED
	4	WATER LOW TEMP
	5	WATER HIGH TEMP
	6	WATER IN MACHINE AT PROGRAM END
	8	NO HEATING
	9	DRUM OVERFILLED
	10	MAX TIME DRAIN
	12	NO LEVEL SENSOR
	16	TIMEOUT HEATING
	17	DOOR LOCK
	27	LEVEL OFFSET
	28	WATER LEVEL HIGH DLCU LEVEL LOW
	29	WATER LEVEL LOW DLCU LEVEL HIGH
126	CO2 BOTTLE EMPTY	
127	DRAWER OUT CLOSE TO START	

Error code		Text
Major	Minor	
12 MAIN DRYER	1	O.H. THERMOSTAT - INLET AIR
	2	O.H. THERMOSTAT - OUTLET AIR
	3	INLET AIR SENSOR - OPEN
	4	INLET AIR SENSOR - SHORT CIRCUITED
	5	OUTLET AIR SENSOR - OPEN
	6	OUTLET AIR SENSOR - SHORT CIRCUITED
	8	CONDENSE WATER CONTAINER IS FULL
	9	HEAT PUMP LOW PRESSURE
	10	HP HIGH PRESSURE CHECK COOLING SYSTEM AND FILTERS
	11	DRYING ERROR WITH RMC PROGRAM
	12	DRYING ERROR WITH AUTOSTOP PROGRAM
	13	DRYING ERROR WITH TIME PROGRAM
	14	GAS ERROR PRESS GAS REST BUTTON
	15	NO VACUUM
	16	VACUUM SWITCH SHORTED
	17	AIRFLOW OBSTRUCTED MAINTENANCE NEEDED
	18	REDISTRIBUTION OF LOAD NEEDED
	253	JUMPER 1
	254	JUMPER 2
	255	JUMPER 3

Error code		Text
Major	Minor	
13 MAIN BARRIER	1	DRUM POSITIONING TIMED OUT
	2	DRUM LOCKING / UNLOCKING
	3	INNER DOOR OPENING
	4	INNER DOOR JACK POSITION
	5	DOOR UNLOCKING
	6	DRUM LOCK POSITION SWITCH
	7	DRUM NOT ROTATING
	8	UNBALANCE SWITCH ON AT PROG START
	9	WATER IN DRUM - CALL SERVICE
	10	WATER IN DRUM - CALL SERVICE
	11	UNLOADING DOOR NOT LOCKED
	12	LOADING DOOR NOT LOCKED
	13	UNLOADING DOOR NOT LOCKED
	14	INNER DRUM DOOR NOT CLOSED
	15	COMPRESSED AIR IS MISSING
	16	DRUM LOCK POSITION SWITCH

Error code		Text
Major	Minor	
14 MAIN W&D	1	EXTRACTION FAILED DRYING ABORTED

Error code		Text
Major	Minor	
15 MAIN POCKET	2	UNLOADING DOOR OPEN
	3	UNLOADING DOOR NOT LOCKED
	17	DOOR LOCK

Error code		Text
Major	Minor	
20 DRUM MOTOR COMMON	1	O.H. DRUM MOTOR
	2	NO MOTOR COMMUNICATION
	3	LOST MOTOR COMMUNICATION

Error code		Text
Major	Minor	
21 DRUM MOTOR EWD	1	HEATSINK TOO HOT
	2	MOTOR TOO HOT
	3	NO INTERLOCK
	4	NO COMMUNICATION
	5	MOTOR SHORT CIRCUIT
	6	INTERLOCK HARDWARE
	7	LOW DC VOLTAGE
	8	HIGH DC VOLTAGE
	12	NO PARAMET. SET IN MCU
	13	UNBALANCE
	15	MOTOR NOT FOLLOW
	255	UNDEFINED ERROR

Error code		Text
Major	Minor	
22 DRUM MOTOR KEB	0	SECURITY INPUT
	1	OVERVOLTAGE
	2	UNDERVOLTAGE
	3	PHASE FAILURE
	4	OVERCURRENT
	6	OVERHEAT INTERNAL
	7	NO OVERHEAT INTERNAL
	8	OVERHEAT POWER MODULE
	9	DRIVE OVERHEAT
	11	NO DRIVE OVERHEAT
	12	POWER UNIT
	13	POWER UNIT NOT READY
	14	POWER UNIT INVALID
	15	LOAD SHUNT FAULT
	16	OVERLOAD
	17	NO OVERLOAD
	18	BUS
	19	OVERLOAD 2
	20	NO OVERLOAD 2
	21	EEPROM DEFECTIVE
	22	POWER UNIT COMMUNICATION
	23	BUS SYNCHRON.
	30	MOTOR PROTECTION
	31	EXTERNAL FAULT
	32	ENCODER 1
	33	POWER FACTOR CONTROL
36	NO OVERHEAT POWER MODULE	
39	SET	
46	PROTECT. ROT. FORWARD	
47	PROTECT. ROT. REVERSE	
49	POWER UNIT CODE INVALID	

Error code		Text
Major	Minor	
23 DRUM MOTOR OBIWAN	1	HEATSINK TOO HOT
	2	MOTOR TOO HOT
	3	NO INTERLOCK
	4	NO COMMUNICATION
	5	MOTOR SHORT CIRCUIT
	6	INTERLOCK HARDWARE
	7	LOW DC VOLTAGE
	8	HIGH DC VOLTAGE
	255	UNDEFINED ERROR

Error code		Text
Major	Minor	
30 FAN MOTOR COMMON	1	O. H. FAN MOTOR

Error code		Text
Major	Minor	
40 INTERNAL COM.	1-10	I/O INTERLOCK Axxx
	11-20	I/O COMMUNICATION Axxx
	21	I/O COMMUNICATION
	22	I/O BOARD MISMATCH

Error code		Text
Major	Minor	
41 INTERNAL COM. I/O TYPE 10	1	CHARGE CIRCUIT
	2	SET SIGNAL, NO TACHO. WAIT 5 MINUTES
	3	ACTUATOR CIRCUIT
	21	CHARGE CIRCUIT
	22	SET SIGNAL, NO TACHO. WAIT 5 MINUTES
	23	ACTUATOR CIRCUIT

Error code		Text
Major	Minor	
42 INTERNAL COM. I/O TYPE 6	1	I/O TYPE 6 INTERNAL ERROR
	2	I/O TYPE 6 POSITION TEST
	3	I/O TYPE 6 EXTRACT TEST

Error code		Text
Major	Minor	
51 EXTERNAL COM. PAYMENT	22	NO CBT COMMUNICATION PRESS TO RETRY

Error code		Text
Major	Minor	
52 EXTERNAL COM. MIS	1	CMIS COMMUNICATION ERROR
	2	DMIS COMMUNICATION ERROR

Error code		Text
Major	Minor	
60 INTERNAL	5	FATAL ERROR INVALID RUNNING MODE
	11	FATAL ERROR EXTERNAL FLASH WRITE
	17	FATAL ERROR INVALID OPTION
	18	FATAL ERROR INVALID MODULE
	28	FATAL ERROR INVALID COIN INPUT
	29	FATAL ERROR INVALID FONT

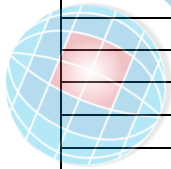

PLATON SERVICE

8 (800) 500-3447
www.platonservice.com

14.3 Description of error codes and causes

MAIN COMMON

10:1 INTERNAL ERROR CPU TACHO

Tacho input on CPU delivers values that is out of range.

Recommended actions:

1. Run motor on highest possible speed in service mode. Check input value for RPM speed.
2. Replace defective component.

10:11 REAL TIME CLOCK OUT OF ORDER

The real time clock is used by the control system for delayed start, measuring time, power failure, error codes, etc.

Upon power on, the communication with the internal real time clock in the control system is established. In case this fails, this error occurs

Recommended actions:

1. Power off the machine for 1 minute and try again.

10:13 INITIALIZATION FAILED

The error code is shown if the hardware initialization has failed to initialize within 15 seconds after power on.

Recommended actions:

1. Press the control knob/start button to retry.
2. Upload a new software that matches the machine configuration and try again.

10:15 MACHINE STOP

This message is shown if input for MACHINE STOP is activated.

This is not an error code but is handled in the same way.

Recommended actions:

1. Reset the Machine Stop Button.
2. Press the control knob to confirm machine stop. Machine will revert to Idle mode.

10:16 EMERGENCY STOP

This message is shown if input for EMERGENCY STOP is activated. This is not an error code but is handled in the same way.

Recommended actions:

1. Reset the Emergency Stop Button.
2. Press the control knob to confirm emergency stop. Machine will revert to Idle mode.

MAIN WASHER

11:1 NO WATER

This error is shown if the programmed water level is not reached within a certain time, typically 10 minutes.

Max. filling time is defined in Config. 1 parameter `MAX FILL TIME`.

This error message can be turned off in Configuration - Error code.

Possible causes:

Long filling times can be caused by a leaking drain valve, blocked filler valve, defective filler valve, defective valve control board, clogged level sensor hose, leaking level system, etc.

Recommended actions:

1. Check for leaking drain valve by filling water to high level in service program.
2. Check for leaking or clogged level sensor system by filling water to high level in service program and then actual level in inputs.
3. Check for malfunction or block filler valve by activating input by input in service program.
4. Monitor a program by using Process viewer in ELS Common Service Tool.

11:2 DOOR OPEN / LOADING DOOR OPEN

This error code will be shown if the control system detect that the input `DOOR CLOSED` has been deactivated during an on-going program. This error code can only occur during an on-going program.

Possible causes:

This can be caused by for example a bad or defective door lock, loose cable to door lock, problem with door lock edge connection, defective input on I/O unit type 10 etc.

Recommended actions:

1. Check door lock functionality in service program, but activating door lock and then by checking inputs.
2. Check electrical connections by reading inputs at the same time as cables carefully moved/pulled.
3. Carefully knock on the door lock to locate intermittent errors.

11:3 DOOR LOCK FAIL / LOADING DOOR NOT LOCKED

This error code will be shown if the control system have not detected the input `DOOR LOCKED` to be active within a certain time after program start, typically 3 seconds.

Possible causes:

This can be caused by a mechanical problem preventing door lock to lock, defective door lock, loose cable connection to door lock, broken cables to door lock or mechanical problem with emergency opening of the door.

Recommended actions:

1. Check door lock functionality in service program, but activating door lock and then by checking check inputs.
2. Check electrical connections by reading inputs at the same time as cables carefully moved/pulled.
3. Carefully knock on the door lock unit to locate intermittent errors.
4. Check DLCU status in service mode for more information on possible causes.

11:4 WATER LOW TEMP

This error code is shown if the temperature sensor indicates temperature below approx. $-9^{\circ}\text{C}/15^{\circ}\text{F}$. Minimum allowed temperature is defined in Config. 2 parameter `MIN PROG TEMP`.

Possible causes:

This low temperature means that the resistance in the sensor is too high ($>23.5\text{k}\Omega$ on all machines except Barrier Washers) or too low ($<97\Omega$ on Barrier washers). This can be caused by, for example, the machine has been stored outdoors, or an open circuit in the sensor or its wiring (all machines except Barrier Washers) or short circuit in the sensor or its wiring (Barrier Washers).

Recommended actions:

1. Measure resistance in temperature sensor and check for open circuit or short circuit in its wiring. The resistance should be as shown in the table below:

Temp	Resistance
$15^{\circ}\text{C} / 59^{\circ}\text{F}$	$7.6\text{ k}\Omega$ ($105,9\Omega$ on Barrier)
$20^{\circ}\text{C} / 68^{\circ}\text{F}$	$6.0\text{ k}\Omega$ ($107,8\Omega$ on Barrier)
$25^{\circ}\text{C} / 77^{\circ}\text{F}$	$4.8\text{ k}\Omega$ ($109,7\Omega$ on Barrier)
2. Monitor a program by using Process viewer in ELS Common Service Tool to detect intermittent errors.

11:5 WATER HIGH TEMP

This error code is shown if the temperature sensor indicates temperature above + 98°C/208°F. Maximum allowed temperature is defined in Config. 2 parameter `MAX PROG TEMP`.

Possible causes:

This high temperature means that the resistance in the sensor is too low (< 350Ω on all machines except Barrier Washers) or too high (>137Ω on Barrier washers). This can be caused by, for example, short circuit in the sensor or its wiring (all machines except Barrier Washers) or an open circuit in the sensor or its wiring (Barrier Washers).

Recommended actions:

1. Measure resistance in temperature sensor and check for open circuit or short circuit in its wiring. The resistance should be as shown in the table below:

Temp - Resistance

15°C / 59°F - 7.6 kΩ (105,9Ω on Barrier)

20°C / 68°F - 6.0 kΩ (107,8Ω on Barrier)

25°C / 77°F - 4.8 kΩ (109,7Ω on Barrier)

Monitor a program by using Process viewer in ELS Common Service Tool to detect intermittent errors.

11:6 WATER IN MACHINE AT PROGRAM END

This error code will only appear at program end.

Error is activated if the level system has not indicated "empty drum" within a certain time, typically 3 minutes.

This error code can also arise if the program is rapid advanced to the end, or if program is aborted.

Maximum allowed drain time can be changed in Config. 2 parameter `MAX DRAIN TIME`.

Level for empty drum is defined in Config. 2 parameter `LEVEL EMPTY`.

This error message can be turned off in Configuration - Error code.

Possible causes:

- Clogged drain
- Foam/ clogged drain pipe
- Incorrect installation of drain pipe/drain system
- Defect drain valve
- Open water valve, filling water

Recommended actions:

1. Check drain for dirt.
2. Blow through the level hose and check that it is not blocked and does not contain any water.
3. Check in the service program that the level control is working correctly.
4. Check for detergent overdosing/remains of foam.
5. Make sure the installation of the drain system follows the installation manual for the machine.
6. Monitor a program by using Process viewer in ELS Common Service Tool.

11:8 NO HEATING

This error code is shown if the temperature is increasing too slowly when heating is active. The limit for this error code is normally set to a water temperature increase of approximately 3°C per 10 minutes but can vary depending on the type of machine and software.

Minimum temperature increase is defined in Config. 2 parameter `MIN TEMP INCREASE`.

Maximum heating time is defined in Config. 2 parameter `MAX HEATING TIME`.

This error message can be turned off in Configuration - Error code.

Possible causes:

This error code can be caused by for example a defective heating element, a break in the power supply to the heating element, defective heating contactor, leaking drain/refill of water, to low water level in program etc.

It can also occur in installations using power control, where number of machines that can heat at the same time is limited.

Recommended actions:

1. Check heating elements and electrical power to heaters.
2. Fill up water in service program, activate heat and monitor level and temperature increase.
3. Check for a leaking drain.
4. Monitor a program by using Process viewer in ELS Common Service Tool.

11:9 DRUM OVERFILLED

This error code is shown if the mechanical level sensor connected to input `DRUM OVERFILLED` detects a high level (used primary in W&D machines)

Possible causes:

This error code can be caused by for example water inlets not closing correctly, faulty level switch, blocked level hose, drops of water in the level hose, foam in drum or level hose, etc.

Recommended actions:

1. Check in the service program that all the water valves are working correctly.
2. Check that the level switch is working correctly. Switch is normally closed.
3. Blow through the level hose and check that it is not blocked and does not contain any water or foam.

11:10 MAX TIME DRAIN

This error code will only occur in drain or extraction modules.

Error is activated if the level system has not indicated "empty drum" within a certain time (approximately 3 min). This time may vary depending on the size of the machine.

Maximum allowed drain time is defined in Config. 2 parameter `MAX DRAIN TIME`.

Level for empty drum is defined in Config. 2 parameter `LEVEL EMPTY`, (may not be changed unless agreed with factory since it affects other functionality as well).

Recommended actions:

1. Check drain for dirt.
2. Blow through the level hose and check that it is not blocked and does not contain any water.
3. Check in the service program that the level control is working correctly.
4. Check for detergent overdosing/remains of foam.
5. Make sure the installation of the drain system follows the installation manual for the machine.
6. Monitor a program by using Process viewer in ELS Common Service Tool.

11:12 NO LEVEL SENSOR

This error code is activated if the CPU detects that there is no electronic level sensor connected.

It can also be caused by a broken cable to the sensor or a broken sensor.

11:16 TIMEOUT HEATING

This error code will be shown if total heating time in a program is longer than a Maximum allowed heating time, typically 2h 30 min.

Maximum allowed heating time is defined in Config. 2 parameter `HEATING TIMEOUT`.

Compared to Error code 11:8 - `NO HEATING`, this error code measures the maximum allowed heating time.

Possible causes:

Could occur if machine heats properly (min. temperature increase during heating is OK), but there is a drain leakage causing repeated fillings.

11:17 DOOR LOCK

This error code is shown if the input for `DOOR LOCKED` is active at program start, i.e. the door is locked although the control system has not requested locking.

Recommended actions:

1. Check door lock functionality in service program, by activating door lock and then by checking inputs.
2. Check DLCU status in service mode for more information on possible causes.
3. If DLCU is in error mode, wait five minutes for automatic reset or manually reset the DLCU in service mode.

11:27 LEVEL OFFSET

This error code is shown at program start if the level sensor indicates a level above what the control system CPU can compensate for. If high level is indicated a attempt is made to first drain the machine.

Maximum allowed level offset is defined in Config. 2 parameter `MAX LEV . ZERO OFFS.`

The drain time before error code is triggered is defined in Config. 2 parameter `MAX DRAIN TIME START.`

Possible causes:

This error can be caused by defective level control, blocked drain, blocked level hose, a drop of water in the level hose, etc.

Recommended actions:

1. Check in the service program that the level control is working correctly.
2. Blow through the level hose and check that it is not blocked and does not contain any water.
3. Check drain for dirt.

11:28 WATER LEVEL HIGH DLCU LEVEL LOW

The DLCU on I/O type 10 contains a mechanical DLCU level switch which ensures that there is no water in the machine when the door unlocks. To ensure that the DLCU level switch functions correctly, the DLCU level switch status is compared with a predefined value from the electronic level sensor. During first fill, this check is made to ensure that the mechanical level switch is activated when the water level exceeds the predefined value. If not, this error code is shown.

Predefined level value is defined in Config. 2 parameter `LEVEL DLCU.`

Possible causes:

- The mechanical level control can be damaged.
- Leakage or clogged level controls air hoses.

Recommended actions:

1. Check function of mechanical level switch by reading DLCU status in service mode.
2. Check the analog level control function by checking value in inputs.
3. Blow through the level hoses and check that they are not blocked and does not contain any water.
4. Check the cables and their connections.

11:29 WATER LEVEL LOW DLCU LEVEL HIGH

The DLCU on I/O type 10 contains a mechanical DLCU level switch which ensures that there is no water in the machine when the door unlocks opens. To ensure that the DLCU level switch functions correctly, the DLCU level switch status is compared with the value from the electronic level sensor. At program start and program end, when the water level is below `LEVEL EMPTY` value, a check is made to ensure that the mechanical level switch is not activated. If it is activated, this error code is shown.

The level empty value is defined in Config. 2 parameter `LEVEL EMPTY.`

Possible causes:

- The mechanical level control can be damaged.
- Mechanical level control is not connected or bad there is bad contact in the connector.
- Leakage or clogged level controls air hoses.
- Incorrect nominal value, possibly caused by a error in the electronic level control.

Recommended actions:

1. Check function of mechanical level switch by reading DLCU status in service mode.
2. Check the analog level control function by checking value in inputs.
3. Blow through the level hoses and check that they are not blocked and does not contain any water.
4. Check the cables and their connections.

11:126 CO2 BOTTLE EMPTY

This is only a warning message.

Shown when CO2 bottle is about to be empty and input `CO2 BOTTLE EMPTY` is activated.

Program will continue when message has disappeared.

11:127 DRAWER OUT CLOSE TO START

This is only a warning message.

Shown if input `DETERGENT BOX SENSOR` is active at program start or during program run if water is supposed to flush in detergent compartment.

The program will pause until input `DETERGENT BOX SENSOR` is deactivated.

The function to check for open detergent box can be turned off in Config 1 `DETERGENT BOX SENSOR`.



PLATON SERVICE

8 (800) 500-34-47

www.platonservice.com

MAIN DRYER

12:1 O.H. THERMOSTAT - INLET AIR

This error code is shown if the input O.H. INLET AIR is deactivated.

Normally this is due to that protection thermostat for inlet air has triggered due to overheating.

The overheating thermostat for inlet air needs to be mechanically restored.

Cut power and turn off gas supply (if gas heated) and check contactors/heat relays before restoring the thermostat.

When the overheating thermostat for inlet air has been restored and the machine is powered up again, the error code is cleared automatically.

The error code can be triggered if:

- The inlet air sensor has stopped operating correctly.
- The fan has stopped operating.
- The airflow is obstructed, by lint, overload, etc.
- The contactor or heat relay has got welded.

If the overheating thermostat for inlet air is not triggered, but there still is an error code:

- Check the harness, connectors and functions by reading the electrical schematic and by using the `SHOW INPUTS` menu when the machine is in service mode.

12:2 O.H. THERMOSTAT - OUTLET AIR

This error code is shown if the input O.H. OUTLET AIR is deactivated.

Normally this is due to that protection thermostat for outlet air has triggered due to overheating.

The overheating thermostat for outlet air needs to be mechanically restored.

Cut power and turn off gas supply (if gas heated) and check contactors/heat relays before restoring the thermostat.

When the overheating thermostat for outlet air has been restored and the machine is powered up again, the error code is cleared automatically.

The error code can be triggered if:

- The outlet air sensor has stopped operating correctly.
- The contactor or heat relay has got welded.

If the overheating thermostat for outlet air is not triggered, but there is still an error code:

- Check the harness, connectors and functions by reading the electrical schematic and by using the `SHOW INPUTS` menu when the machine is in service mode.

12:3 INLET AIR SENSOR - OPEN

The error code is shown if the analog input INLET AIR TEMP. (PT100) is reading a resistance of more than approximately 185 Ω . Probably caused by broken PT100 sensor or wiring.

If the inlet air temperature in the `SHOW INPUTS` menu show a temperature of 222 °C the inlet air sensor is considered open.

When the inlet air sensor is restored the error code is automatically reset and the ongoing program will continue.

A long press on the control knob/start button will make the control system reset and ongoing program will be ended.

The error code can be triggered if:

- The sensor, harness or connector is broken. The sensor shall measure around 110 Ohm in room temperature, see table. (Measure direct over the sensor connectors).

If the measure of inlet air sensor is OK, but there is still an error code:

- Check the harness, connectors and functions by reading the electrical schematic and by using the `SHOW INPUTS` menu when the machine is in service mode.

Temp - Sensor resistance

0°C / 32°F - 100 Ω

20°C / 68°F - 107 Ω

30°C / 86°F - 112 Ω

200°C / 392°F - 176 Ω

12:4 INLET AIR SENSOR - SHORT-CIRCUITED

The error code is shown if the analog input INLET AIR TEMP (PT100) is reading a resistance of less than 100 Ω . Probably caused by broken PT100 sensor or damaged wiring.

If the inlet air temperature in the `SHOW INPUTS` menu show a temperature of 0 °C the inlet air sensor is shorted.

When the inlet air sensor is restored the error code is automatically reset and the ongoing program will continue.

A long press on the control knob/start button will make the control system reset and ongoing program will be ended.

The error can be triggered if:

- The sensor, harness or connector is shorted. The sensor shall measure around 110 Ohm in room temperature, see table. (Measure direct over the sensor connectors).

If the measure of inlet air sensor is OK, but there is still an error code:

- Check the harness, connectors and functions by reading the electrical schematic and by using the `SHOW INPUTS` menu when the machine is in service mode.

Temp - Sensor resistance

0°C / 32°F - 100 Ω

20°C / 68°F - 107 Ω

30°C / 86°F - 112 Ω

200°C / 392°F - 176 Ω

12:5 OUTLET AIR SENSOR - OPEN

The error code is shown if the analog input OUTLET AIR TEMP (NTC) is reading a resistance of more than approximately 26.7 k Ω . Probably caused by broken NTC sensor or wiring.

If the outlet air temperature in the `SHOW INPUTS` menu shows a temperature of -10 °C the outlet air sensor is open.

When the outlet air sensor is restored the error code is automatically reset and the ongoing program will continue.

A long press on the control knob/start button will make the control system reset and ongoing program will be ended.

The error code can be triggered if:

- The sensor, harness or connector is broken. The sensor shall measure around 5 K Ohm in room temperature, see table. (Measure direct over the sensor).

If the measure of outlet air is OK, but there is still an error code:

- Check the harness, connectors and functions by reading the electrical schematic and by using the `SHOW INPUTS` menu when the machine is in service mode.

Temp - Sensor resistance

-10 °C - 26.7 k Ω

15 °C - 7.6 k Ω

20 °C - 6.0 k Ω

25 °C - 4.8 k Ω

30 °C - 3.9 k Ω

100 °C - 0.33 k Ω

12:6 OUTLET AIR SENSOR - SHORT-CIRCUITED

The error code is shown if the analog input OULET AIR TEMP (NTC) is reading a resistance of less than 330 Ω . Probably caused by broken NTC sensor or damaged wiring.

If the outlet air temperature in the `SHOW INPUTS` menu shows a temperature of 100 °C the outlet air sensor is shorted.

When the outlet air sensor is restored the error code is automatically reset and the ongoing program will continue.

A long press on the control knob/start button will make the control system reset and ongoing program will be ended.

The error code can be triggered if:

- The sensor, harness or connector is broken. The sensor shall measure around 5 K Ohm in room temperature, see table. (Measure direct over the sensor).

If the measure of outlet air sensor is OK, but there is still an error code:

- Check the harness, connectors and functions by reading the electrical schematic and by using the `SHOW INPUTS` menu when the machine is in service mode.

Temp - Sensor resistance

-10 °C - 26.7 k Ω

15 °C - 7.6 k Ω

20 °C - 6.0 k Ω

25 °C - 4.8 k Ω

30 °C - 3.9 k Ω

100 °C - 0.33 k Ω

12:8 CONDENSE WATER CONTAINER IS FULL

The pump will run when a program starts for normally 15 seconds. Then it will run again after normally 3 minutes.

The pump will also run if the input for the float is triggered.

The error code is activated if the input CONDENSER TANK is still activated after 15 seconds.

This means that the pump has tried to empty the condense water container without the signal from the float in the condense water container has been deactivated.

When the float in the condense water container is restored it is possible to reset the error code from the control system.

The error code is reset from the control system by a short press on the control knob/start button. A long press on the control knob/start button will make the control system reset and ongoing program will be ended.

The error code can be triggered if:

- The condense water container is full and the pump is not operating. Check the pump by activating the `CONDENSER PUMP` menu in the `ACTIVATE OUTPUTS` menu when the machine is in service mode.
- If the pump is running and no water is coming out, the drain is blocked or the float is out of order.
- If water coming out of the hose, it might be partly blocked.

If the pump does not run or if there is no level in the condense water container check the harness, connectors and functions by reading the electrical schematic and by using the `SHOW INPUTS` menu when the machine is in service mode.

12:9 HEAT PUMP LOW PRESSURE

The error code is shown if the input HP LOW PRESSURE (low pressure switch, P2) has tripped.

The error code can be triggered if there is too little refrigerant in the heat pump or by damaged wiring or connectors.

It can also be triggered if machine is started in a cold environment, or started with clogged lint filters.

The error can be restored with the knob when the pressure is restored and the ongoing program will continue.

Recommended actions:

1. Check the harness, connectors and functions by reading the electrical schematic and by using the `SHOW INPUTS` menu when the machine is in service mode.
2. Check airflow and clean filters.
3. Try to run again, if error still present, check the heat pump for gas leakage.

12:10 HP HIGH PRESSURE CHECK COOLING SYSTEM AND FILTERS

The error is activated if the input HP HIGH PRESSURE (high pressure switch, P1) has tripped.

The error can be triggered if there is no cooling water to machine or if the airflow is obstructed, by lint, overload, etc.

The error can be restored with the knob when the pressure is restored and the ongoing program will continue.

Recommended actions:

1. Check the harness, connectors and functions by reading the electrical schematic and by using the `SHOW INPUTS` menu when the machine is in service mode.
2. Check cooling water supply.
3. Check airflow and clean filters.

12:11 DRYING ERROR WITH RMC PROGRAM

The error code is shown if the analog input RMC does not register the STOP VALUE FOR RMC PROGRAM reached within the maximum drying time (normally 90 minutes). When the error is triggered the machine will automatically go to the cooling module before the program ends.

The program is ended and the error code is reset by opening the door.

If the clothes are still wet after maximum drying time and the dryer is not overloaded, check that the heating system is working correct by using the `ACTIVATE OUTPUTS` menu when the machine is in service mode.

Note!

Make sure that the fan is active before turning on the heat.

If the clothes are dry, check the RMC system and harness, connectors and functions by reading the electrical schematic and by using the `SHOW INPUTS` menu when the machine is in service mode.

- RMC value no load = 0%
- RMC value 100K Ohm between lifter and drum = ~24% (Putting your hand over the lifter onto the drum will result in approximately 20% RMC value)
- RMC value system short circuit = 50%

12:12 DRYING ERROR WITH AUTOSTOP PROGRAM

The error code is shown if the analog input OULET AIR TEMP (NTC) does not register the STOP VALUE FOR AUTOSTOP PROGRAM reached within the maximum drying time (normally 90 minutes).

When the error is triggered the machine will automatically go to the cooling module before the program ends.

The program is ended and the error code is reset by opening the door.

If the clothes are still wet after maximum drying time and the dryer is not overloaded, check that the heating system is working correct by using the `ACTIVATE OUTPUTS` menu when the machine is in service mode.

Note!

Make sure that the fan is active before turning on the heat.

If the clothes are dry, check the outlet air sensor and harness, connectors and functions by reading the electrical schematic and by using the `SHOW INPUTS` menu when the machine is in service mode.

12:13 DRYING ERROR WITH TIME PROGRAM

The error code is shown if a time program has continued longer than the maximum drying time (normally 90 minutes) without the door has been opened.

When the error is triggered the machine will automatically go to the cooling module before the program ends.

The program is ended and the error code is reset by opening the door.

12:14 GAS ERROR PRESS GAS RESET BUTTON

The error code is shown if input GAS ERROR is activated. This means that no flame has been detected by the gas control box.

The metal probe of the flame sensor generates an electrical current when exposed to the burner's flame. This signal is detected by the ignition control module which, in turn, cuts off the gas valve immediately if the sensor does not indicate flame within 3 attempts at each 10 seconds. The integrity of the sensor's electrical connection is, therefore, critical to proper operation of this system. When the gas control box is in error mode, a red LED is active on the gas control box. The gas control box also trigs input GAS ERROR on the control system , which generates the error code.

The control system sends a reset signal to the gas control box via output GAS ERROR RESET by a short press on the start button or service button (depending on market and segment). When the gas control box receive a reset command it removes the error. The control system will automatically restart the program when the error is removed from the gas control box and when heat is allowed (vacuum needed) the gas control box will try to ignite the gas again.

A long press on the control knob/start button will make the control system reset and ongoing program will be ended.

The gas error can also be reset at the gas control box. The machine will automatically restart when the error is restored.

The error code can be triggered if:

- The gas control box fails to ignite. Check the gas supply and nozzle pressure.

If the gas control box do not have a gas error but the control system does, check the harness, connectors and functions by reading the electrical schematic and by using the SHOW INPUTS menu when the machine is in service mode.

12:15 NO VACUUM

The error code is shown if the input VACUUM is not activated within set time in parameter TIMEOUT VACUUM.

The error code is reset from the control system by a short press on the control knob/start button. A long press on the control knob/start button will make the control system reset and ongoing program will be ended.

The time is defined in Config. 1 parameter TIMEOUT VACUUM.

The error code can be triggered if:

- The fan is not operating or blows in the wrong direction.
- The airflow is obstructed. (Cleaning of evacuation channel/chimney and air flaps).
- The vacuum switch sensor or hose is disconnected.
- The lint drawer is open, etc.

Check the harness, connectors and functions by reading the electrical schematic and by using the SHOW INPUTS and ACTIVATE OUTPUTS menus when the machine is in service mode.

12:16 VACUUM SWITCH SHORTED

The error code is shown if the input VACUUM was already activated when a program was started.

The error code is reset from the control system by a short press on the control knob/start button. A long press on the control knob/start button will make the control system reset and ongoing program will be ended.

Recommended actions:

1. Check the vacuum switch/pressure sensor, harness, connectors and functions by reading the electrical schematic and by using the SHOW INPUTS menu when the machine is in service mode.

12:17 AIRFLOW OBSTRUCTED MAINTENANCE NEEDED

The error is shown if input INTERNAL FILTER is activated.

Error can be triggered by clogged internal filter, damaged vacuum switch or harness.

Recommended actions:

1. Check and clean internal filters, see maintenance manual.
2. Check the harness, connectors and functions by reading the electrical schematic and by using the SHOW INPUTS menu when the machine is in service mode.
3. If permanent clean heat pump box.

12:18 REDISTRIBUTION OF LOAD NEEDED

The error code is shown if the input VACUUM has deactive several times during program run and the function to handle vacuum error during program run has failed to recreate vacuum in the machine. The error code is reset from the control system by a short press on the control knob/start button. A long press on the control knob/start button will make the control system reset and ongoing program will be ended.

The error code can be triggered if:

- The load is blocking the airflow.

Check the load and redistribute it in the drum.

12:253 JUMPER 1

The error code is shown if input JUMPER 1 is not activated.

Jumpers are a by-pass of inputs not used in the machine. How many jumpers used is depending on configuration.

When the jumper is restored the error code is automatically reset and the ongoing program will continue. A long press on the control knob/start button will make the control system reset and ongoing program will be ended.

Recommended actions:

Check the harness, connectors and functions by reading the electrical schematic and by using the `SHOW INPUTS` menu when the machine is in service mode.

12:254 JUMPER 2

The error code is shown if input JUMPER 2 is not activated.

Jumpers are a by-pass of input not used in the machine. How many jumpers used is depending on configuration.

When the jumper is restored the error code is automatically reset and the ongoing program will continue. A long press on the control knob/start button will make the control system reset and ongoing program will be ended.

Recommended actions:

1. Check the harness, connectors and functions by reading the electrical schematic and by using the `SHOW INPUTS` menu when the machine is in service mode.

12:255 JUMPER 3

The error code is shown if input JUMPER 3 is not activated.

Jumpers are a by-pass of input not used in the machine. How many jumpers used is depending on configuration.

When the jumper is restored the error code is automatically reset and the ongoing program will continue. A long press on the control knob/start button will make the control system reset and ongoing program will be ended.

Recommended actions:

1. Check the harness, connectors and functions by reading the electrical schematic and by using the `SHOW INPUTS` menu when the machine is in service mode.

MAIN BARRIER

13:1 DRUM POSITIONING TIMED OUT

The error code is shown if input POSITION DRUM 1 and POSITION DRUM 2 is not activated within set time in Config parameter DRUM POS TIMEOUT.

Recommended actions:

1. Check inputs from positioning sensors DP1 and DP2.

13:2 DRUM LOCKING / UNLOCKING

The error code is shown if drum is not able to unlock/lock when expected.

This is detected by the input sensors DRUM UNLOCKED (FC1) and DRUM LOCKED (FC2).

Recommended actions:

1. Check functionality of drum lock position sensors FC1 and FC2.
2. Check functionality of drum locking piston, i.e that it operates normal and could activate/inactivate. This could be done by running a positioning sequence in service program or by running a program.

13:3 INNER DOOR OPENING

Machine indicates that the automatic inner door JACK (Piston) has not left the home position within a reasonable time.

The error code is shown if the sensor for JACK AT HOME (backwards position) is still active when JACK is expected to be in forward position.

Recommended actions:

1. Check functionality JACK_AT_HOME sensor DP8, i.e active when jack is in backward position, inactive when JACK is in forward position.
2. Check functionality for JACK, i.e that it could move forward when expected.

13:4 INNER DOOR JACK POSITION

Machine indicates that the inner door opening jack is not in home position when the drum is rotating.

The error code is shown if input JACK AT HOME is not active when the reported motor speed is not zero.

Recommended actions:

1. Check functionality for JACK, i.e that it is in backwards position when expected.
2. Check functionality JACK_AT_HOME sensor DP8, i.e active when jack is in backward position, inactive when JACK is in forward position.
3. Check wiring to JACK_AT_HOME sensor DP8, bad contact in the sensor could cause this problem.

13:5 DOOR UNLOCKING

Machine indicates that either loading or unloading door is not able to unlock.

The error code is shown if inputs LOADING DOOR LOCKED or UNLOADING DOOR LOCKED does not get inactive within a reasonable time after door unlock command is sent.

Recommended actions:

1. Check door lock functionality in service program, by activating door lock and then by monitoring input and output status under Check inputs and outputs.
2. Check electrical connections by reading inputs at the same time as cables carefully moved/pulled.

13:6 DRUM LOCK POSITION SWITCH

The error code is shown if inputs DRUM UNLOCKED and DRUM LOCKED are both active or inactive at the same time during program run. Since it occurs during program run it is required to turn power off to the machine to clear the error message.

Possible causes:

Heavy unbalance in drum that prevents the motor to position the drum. Worst case scenario is wet load in one compartment.

Could also depend on problems with indexing sensors, washer I/O board or malfunction in mechanical drum lock function.

Recommended actions:

1. Check inputs from indexing sensors FC1 and FC2.
2. Run a positioning sequence with wet load in one compartment to test functionality.

13:7 DRUM NOT ROTATING

The error code is shown if positioning sensor on input on J201 is not indicating rotation when rotation is expected during program run.

Recommended actions:

1. Check that drive belt is not broken.
2. Check positioning sensor on input J201.

13:8 UNBALANCE SWITCH ON AT PROG START

The error code is shown if unbalance switch is active at program start.

Recommended actions:

1. Check unbalance switch for proper alignment.
2. Check unbalance switch for electrical fault.

13:9 WATER IN DRUM - CALL SERVICE

This error code will be shown if the control system detects water above safety level when program is finished.

Possibly caused by broken inlet valve and / or drain valve.

Recommended actions:

1. Turn off water inlet to machine.
2. Manually open the drain valve.
3. Check reason for valve malfunction.

13:10 WATER IN DRUM - CALL SERVICE

This error code will be shown if the control system detects water above safety level in idle mode. Possibly caused by broken inlet valve and / or drain valve.

Recommended actions:

1. Turn off water inlet to machine.
2. Manually open the drain valve.
3. Check reason for valve malfunction.

13:11 UNLOADING DOOR NOT LOCKED

This error code will be shown if the control system has not detected the input UNLOADING DOOR LOCKED to be active within a certain time after closing the unloading door.

Possible causes:

This can be caused by a mechanical problem preventing door lock to lock, defective door lock, loose cable connection to door lock, broken cables to door lock or mechanical problem with emergency opening of the door.

Recommended actions:

1. Check door lock functionality in service program, by activating door lock and then by monitoring input status under Check inputs and outputs.
2. Check electrical connections by reading inputs at the same time as cables carefully moved/pulled.
3. Carefully knock on the door lock unit to locate intermittent errors.

13:12 LOADING DOOR NOT LOCKED

This error code will be shown if the control system detects that the input LOADING DOOR LOCKED has been deactivated during an on-going program.

Possible causes:

This can be caused by a mechanical problem preventing door lock to lock, defective door lock, loose cable connection to door lock, broken cables to door lock or mechanical problem with emergency opening of the door.

Recommended actions:

1. Check door lock functionality in service program, by activating door lock and then by monitoring input status under Check inputs and outputs.
2. Check electrical connections by reading inputs at the same time as cables carefully moved/pulled.
3. Carefully knock on the door lock unit to locate intermittent errors.

13:13 UNLOADING DOOR NOT LOCKED

This error code will be shown if the control system detects that the input UNLOADING DOOR LOCKED has been deactivated during an on-going program.

Possible causes:

This can be caused by a mechanical problem preventing door lock to lock, defective door lock, loose cable connection to door lock, broken cables to door lock or mechanical problem with emergency opening of the door.

Recommended actions:

1. Check door lock functionality in service program, by activating door lock and then by monitoring input status under Check inputs and outputs.
2. Check electrical connections by reading inputs at the same time as cables carefully moved/pulled.
3. Carefully knock on the door lock unit to locate intermittent errors.

13:14 INNER DRUM DOOR NOT CLOSED

This error code will be shown if the control system detects that the input INNER DOOR OPEN is activated during program start or becomes activate when drum is ordered to drive/drum is rotating.

Recommended actions:

1. Check functionality of INNER DOOR OPEN SENSOR (DP7), i.e inactive when door is closed and active when door is open.
2. Check door lock functionality in service program, by activating door lock and then by monitoring input status under Check inputs and outputs.

13:15 COMPRESSED AIR IS MISSING

Machine indicates that compressed air is missing.

This error code will be shown if the control system detects that the input COMPRESSED AIR PRESENT is not activated.

Recommended actions:

1. Check compressed air pressure to machine, valves is open, compressor on etc.
2. Check that input COMPRESSED AIR PRESENT activates when compressed air is present.

13:16 DRUM LOCK POSITION SWITCH

The error code is shown if inputs DRUM UNLOCKED and DRUM LOCKED are both active or inactive at the same time during positioning sequence. By pressing the start button it is possible to have another trial.

Possible causes:

Heavy unbalance in drum that prevents the motor to position the drum. Worst case scenario is wet load in one compartment. Could also depend on problems with indexing sensors, washer I/O board or malfunction in mechanical drum lock function.

Recommended actions:

1. Check inputs from indexing sensors FC1 and FC2.
2. Run a positioning sequence with wet load in one compartment to test functionality.

MAIN W&D**14:1 EXTRACTION FAILED DRYING ABORTED**

Only on Wash & Dryer. If extraction is omitted, the drying sequence will also be omitted.



PLATON SERVICE

8 (800) 500-34-41

www.platonservice.com

MAIN DRYER

15:2 UNLOADING DOOR OPEN

Only on Pocket washer:

This error code will be shown if the control system detects that the input DOOR CLOSED 2 (unloading side) has been deactivated during an on-going program.

The error can only occur during an on-going program.

Possible causes:

This can be caused by for example a bad or defective door lock, loose cable to door lock, problem with door lock edge connection, defective input on I/O unit type 10 etc.

Recommended action:

1. Check door lock functionality in service program, but activating door lock and then by checking inputs.
2. Check electrical connections by reading inputs at the same time as cables carefully moved/pulled.
3. Carefully knock on the door lock to locate intermittent errors.

15:3 UNLOADING DOOR NOT LOCKED

Only on Pocket washer:

This error code will be shown if the control system detects that the input DOOR LOCKED 2 has not been activated within a certain time after unloading door is closed.

It will also be activated if the input DOOR LOCKED 2 has been deactivated during an on-going program.

Possible causes:

This can be caused by a mechanical problem preventing door lock to lock, defective door lock, loose cable connection to door lock, broken cables to door lock or mechanical problem with emergency opening of the door.

Recommended actions:

1. Check door lock functionality in service program, but activating door lock and then by checking check inputs.
2. Check electrical connections by reading inputs at the same time as cables carefully moved/pulled.
3. Carefully knock on the door lock unit to locate intermittent errors.
4. Check DLCU 2 status in service mode for more information on possible causes.

15:17 DOOR LOCK

Only on Pocket washer running with one door setup.

This error code is activated if the input for DOOR LOCKED 2 is active at program start, i.e. the door is locked although the control system has not requested locking.

Possible causes:

- DLCU 2 is in error mode after previous program run.
- Door lock solenoid broken.

Recommended actions:

1. Check door lock functionality in service program, by activating door lock and then by checking check inputs.
2. Check DLCU 2 status in service mode for more information on possible causes.
3. If DLCU 2 is in error mode, wait five minutes for automatic reset or manually reset the DLCU 2 in service mode.

DRUM MOTOR COMMON

20:1 O.H. DRUM MOTOR

This error code will be shown if the control system detects that the input OH DRUM MOTOR is deactivated during program run.

The overheating protection is automatically restored. When the overheating protection is restored the error code is automatically reset and the ongoing program will continue. A long press on the control knob/start button will make the control system reset and ongoing program will be ended.

The error code can be triggered if:

1. The motor is very warm. Check that the vent holes in the motor are not covered.
If the overheating protection is not triggered, but there is still an error code:
2. Check the harness, connectors and functions by reading the electrical schematic and by using the `SHOW INPUTS` menu when the machine is in service mode.

20:2 NO MOTOR COMMUNICATION

This error code occurs if the first message sent from the CPU to the MCU was not replied to during start up.

Recommended actions:

1. Check that there is power reaching the MCU. Check the fuses in the Protection Cable. If one of the components in the Protection Cable is damaged, the cable must be replaced.
2. Check that the green power indication LED on the MCU is on. The LED can be seen by looking down by the MCU edge connections.
3. Check that the communication cable between the CPU board and the MCU is intact and not damaged. Measure also with a reference instrument to see whether there is contact between all the leads in the communication cable.

20:3 LOST MOTOR COMMUNICATION

This error code occurs if the communication between the CPU and the MCU has stopped working.

Recommended actions:

1. Check that there is power reaching the MCU. Check the fuses in the Protection Cable. If one of the components in the Protection Cable is damaged, the cable must be replaced.
2. Check that the indicator LED on the MCU is on. The LED can be seen by looking down by the MCU edge connections.
3. Check that the communication cable between the CPU board and the MCU is intact and not damaged. Measure also with a reference instrument to see whether there is contact between all the leads in the communication cable.

DRUM MOTOR EWD

21:1 HEATSINK TOO HOT

This error code is generated by the MCU for drum motor.

There is a temperature sensor (NTC) mounted on the MCU cooling flange next to the power transistors in the output stage. If the temperature of the cooling flange gets too high ($> 90^{\circ}\text{C}$) the error code will be set to protect the transistors.

The cause of high cooling flange temperature can be e.g. a stiff drum in combination with intensive use and high ambient temperature. There may also be an error in the motor (sticking bearings or short circuit in windings, which impairs the efficiency of the motor).

Recommended actions:

1. Make sure the drum turns easily.
2. Check the value on the error code counter for the error code.
3. Check the last 8 MCU error codes.
4. Start a 90°C normal program with load on continuous operation and measure the temperature of the motor and MCU.
5. Replace the defective part.

21:2 MOTOR TOO HOT

This error code is generated by the MCU for the drum motor.

Each time the motor is started from stationary, the MCU will first measure the resistance between two phases in the motor. The MCU processor governs the output transistors so that a DC current flows between two phases in the motor winding. The actuation of the transistors is a measure of the voltage applied to the winding and the resistance can be calculated using the current and voltage values. The resistance can then be converted to a temperature since the winding resistance at 20°C and the temperature coefficient are known. If the average value of the four latest temperature readings is higher than the maximum motor temperature (e.g. 150°C), the error code will be shown.

Possible causes:

The cause of high motor temperature can be a stiff drum, possibly in combination with intensive use and high ambient temperature. There may also be an error in the motor (sticking bearings or short circuit in windings, which impairs the efficiency of the motor). There could also be a contact error in the connectors between the MCU and the motor or an error in the motor cable. An error in MCU temperature measurement circuits can also occur.

Recommended actions:

- Make sure the drum turns easily.
- Check the value on the error code counter for the error code.
- Check the last 8 MCU error codes.
- Measure the three phases to the phase resistors on the MCU motor connector (disconnect MCU and take the reading in the cable connector) to make sure they are the same.
- Start a 90°C normal program with load on continuous operation and measure the temperature of the motor and MCU.
- Replace the defective part.

21:3 NO INTERLOCK

This error code is generated by the MCU for drum motor.

The MCU must be powered with 230V / 50 or 60 Hz on the interlock input in order to drive the motor. This signal is a confirmation that the door is closed and locked.

MCU receives its commands to rotate the drum from the CPU via a serial communication link between the MCU and CPU. Since the CPU also has access to the interlock signal, the CPU must never send a run command to the MCU if the interlock signal is missing. If this does happen, this error code will be shown.

Possible causes:

The cause of this error code being activated can be e.g. a break in the cable leading the interlock signal to the MCU. There may also be an error in the connector in the door lock, which connects 230V / 50 Hz to the interlock signal. An error in the interlock circuits of the MCU can also set this error code.

Recommended actions:

1. Use a multimeter to check that the interlock signal is present on X302:1-2 when the door lock is activated. Read also bit 1 in the second byte under `MCU STATUS` in the service program (the bits are numbered from 0 to 7 where bit 0 is on the far right). If bit 1 in the second byte is 1 then the lock is open, while a 0 indicates that the lock is closed.
2. Replace the defective part.

21:4 NO COMMUNICATION

This error code is generated by the MCU for drum motor.

MCU detects there is there is a problem in communication with CPU.

Possible causes:

Bad contact in harness or connectors between CPU and MCU.

Recommended actions:

1. Check wiring, connections between CPU and MCU.

21:5 MOTOR SHORT CIRCUIT

This error code is generated by the MCU for drum motor.

The MCU reads the power consumption of the motor continuously. If the current for some reason exceeds a predetermined limit, the MCU will cut the current to the motor. After the motor has stopped (= tachometer indicates stationary motor), the MCU will attempt to restart it. If the MCU then detects high motor current again, this error code will be activated. If on restarting after a first short circuit, the MCU rotates normally, the error code will not be shown.

Possible causes:

This error code can be activated for a number of reasons:

- Short circuit in motor. Measure motor windings with a Motor Tester.
- Short circuit internally in motor winding (impaired efficiency, higher current consumption).
- Short circuit in motor cables.
- Short circuit in connectors.
- Drops of water causing short circuits in the motor connector.
- Short circuit in the MCU output transistors.
- Bad contact in tacho signal.
- Bad contact in interlock signal.

Recommended actions:

1. If the error is a stable one, it is generally not difficult to locate the defective unit through resistance measurement and testing with the service program. Measure motor windings with a Motor Tester.
2. Further information can be obtained by studying the contents of `MCU ERROR LOG 1` and `MCU ERROR LOG 2`. Review following:

`SHORT CIRCUIT 2` (specifies how many times the error code has been active).

`SHORT CIRCUIT 1` (specifies how many times the current limit has been exceeded. The difference between short circuit 1 and short circuit 2 indicates how many times there has been a short circuit 1 that has not been confirmed when restarting the motor).

`LAST FAULT CODE N/8` (shows the 8 latest error codes).

`TACHO ERR. LOW SPEED` (can give a clue in case of intermittent errors).

`TACHO ERR. HIGH SPEED` (can give a clue in case of intermittent errors).

21:6 INTERLOCK HARDWARE

This error code is generated by the MCU for drum motor.

The MCU must be powered with 230V / 50 or 60 Hz on the interlock input in order to drive the motor. The interlock circuits in the MCU have been split into two channels so that a component error in MCU cannot give a false confirmation that the door is locked. These two channels are checked against each other. If this check gives an incorrect result this error code will be shown.

Possible cause:

The reason for this error code being activated can be attributed to an error in the interlock circuits in motor control.

Recommended actions:

1. Replace MCU.

21:7 LOW DC VOLTAGE

This error code is generated by the MCU for drum motor.

The MCU constantly measures the voltage over the mains input. If the voltage is below a predefined limit, the MCU will shut off the current to the motor. Once the motor has stopped (= the tach sensor indicates that the motor is stationary), the MCU checks to see whether the input voltage is still low. If it is, this error code is shown. The reason for this error code being activated can be low mains voltage or that the machine's on/off switch has been operated in an unsuitable manner.

Further information can be obtained by studying the contents of MCU ERROR LOG 1 and MCU ERROR LOG 2:

- UNDERVOLTAGE 2 (specifies how many times this error code has been active).
- UNDERVOLTAGE 1 (specifies how many times the voltage has dropped below the limit. The difference between undervoltage 1 and undervoltage 2 indicates how many times there has been an undervoltage 1 without it being confirmed when the motor has stopped).
- LAST FAULT CODE N/8 (shows the 8 latest error codes) Undervoltages can be registered even during normal operation. Consequently, a small number of registrations need not mean that there is an error in the MCU.

Recommended actions:

1. Check that the supply voltage is stable and never drops below nominal voltage - 10%.
2. Check the fuses and cables.
3. Check the supply voltage in the network cabling and at the MCU in the machine.

21:8 HIGH DC VOLTAGE

This error code is generated by the MCU for drum motor.

The MCU constantly measures the voltage over the mains input. If the voltage exceeds a predefined limit, the MCU will shut off the current to the motor. Once the motor has stopped (= the tach sensor indicates that the motor is stationary), the MCU checks to see whether the input voltage is still high. If it is, this error code is shown.

Recommended actions:

1. Check incoming AC voltage.

21:12 NO PARAMET. SET IN MCU

This error code is generated by the MCU for drum motor.

The MCU contains several different parameter sets for different motors. During power up the control system checks that the correct parameter set digit is written into the MCU. If not, the control system will write down the parameter set digit defined in fixed configuration.

If the MCU discovers that no parameter set value is written down into the MCU, the error code will be shown.

Possible causes:

This can be caused by wrong software in CPU or wrong MCU for the current machine.

Recommended actions:

1. Make sure correct machine software and correct MCU are used.

21:13 UNBALANCE

This error code is generated by the MCU for drum motor.

The MCU monitors the unbalance switch status. If the status is active already at program start, this error code is shown.

21:15 MOTOR NOT FOLLOW

This error code is generated by the MCU. The MCU must always receive information on the rotation of the motor from the tacho sensor in order to rotate. If the tacho sensor is not working, the motor can rotate for max. 10 seconds during the starting process. After this period, this error code will be activated.

Possible causes:

- Break in the cables between the tacho sensor and the MCU.
- Break in connectors in tacho cables.
- Break in one of the phases to the motor (cables or connectors). This error can be suspected if the motor does not rotate for 10 seconds (the motor will not start with only two phases).
- Error in tacho generator.
- Error in tacho circuits in the MCU.

Further information can be obtained by studying the contents of `MCU ERROR LOG 1` and `MCU ERROR LOG 2`. Study the following:

- `MOTOR NOT FOLLOW` (specifies how many times this error code has occurred).
- `LAST ERROR CODE N/8` (shows the 8 latest error codes).
- `TACHO ERR. LOW SPEED` (can give a clue in case of intermittent errors).
- `TACHO ERR. HIGH SPEED` (can give a clue in case of intermittent errors).

Recommended actions:

1. Replace the defective part.

21:255 UNDEFINED ERROR

This error code is generated by the MCU. The MCU reports an error that is not defined.



PLATON SERVICE
8 (800) 500-34-41
www.platonservice.com

DRUM MOTOR KEB

22:0 SECURITY INPUT

Machine indicates that Interlock signal is missing to MCU.

Internal MCU error code STO.

The interlock signal is missing to MCU STO1+ or STO2+ inputs when expected to be active.

Recommended actions:

1. Verify STO 1+ signal from Loading Door or Unloading door locked sensors.
2. Verify STO 2+ signal from Emergency switch on loading or unloading side.

22:1 OVERVOLTAGE

The Motor Control Unit indicates error E.OP.

Voltage in DC-link too high.

Internal message 1.

Recommended actions:

1. Verify input voltage supply to machine (all phases).
2. Check that input choke is connected.
3. Check if braking resistor is defective.
4. Switch off the mainpower for 2 minutes.
5. Restart the machine.

22:2 UNDERVOLTAGE

The Motor Control Unit indicates error E.UP.

Voltage in DC-link too low.

Internal message 2.

Recommended actions:

1. Verify input voltage supply to machine (all phases).
2. Switch off the mainpower for 2 minutes.
3. Restart the machine.

22:3 PHASE FAILURE

The Motor Control Unit indicates error E.UPh.

One phase of input voltage missing. (Ripple detected).

Internal message 3.

Recommended actions:

1. Check power supply.
2. Check for blown fuses.

22:4 OVERCURRENT

The Motor Control Unit indicates error E.OC.

Peak current too high.

Internal message 4.

Recommended actions:

1. Verify that the load in the machine does not exceed maximum load.
2. Verify that the load in the machine have distributed correctly before spin.
3. Check FC for short-circuit at output transistors.
4. Check motor including cable for short-circuit.
5. Switch off the main power to machine for 5 minutes.
6. Restart the machine.

22:6 OVERHEAT INTERNAL

The Motor Control Unit indicates error E.OHI.

Internal overheating in frequency controller. Can only be reset when internal temperature has dropped by 3 °C.

This is indicated by message E.nOHI. See also error code 22:7.

Internal message 6.

Recommended actions:

1. Switch off the main power to machine for 30 minutes.
2. Restart the machine.

22:7 NO OVERHEAT INTERNAL

The Motor Control Unit indicates error E.nOHI.

Error `OVERHEAT INTERNAL` is reset. See also error code 22:6.

Internal message 7.

Recommended actions:

1. Switch off the main power to machine for 5 minutes.
2. Restart the machine.

22:8 OVERHEAT POWER MODULE

The Motor Control Unit indicates error E.OH.

Too high temperature on power module heat sink.

Error can only be reset when temperature is normal again. This is indicated by message E.nOH. See also error code 22:36.

Internal message 8.

Recommended actions:

1. Check that cooling fan is working and that fan grid is not clogged..
2. Check that heat sink is not soiled.
3. Very high ambient temperature.
4. Switch off the main power to machine for 30 minutes.
5. Restart the machine.

22:9 DRIVE OVERHEAT

The Motor Control Unit indicates error E.dOH.

Motor temperature too high. Can only be reset when motor temperature has dropped (E.ndOH, Resistance at terminals T1/T2 > 1650 Ω) This is indicated by message E.ndOH. See also error code 22:11)

Internal message 9.

Recommended actions:

1. Switch off the mainpower for 30 minutes until motor has cooled down.
2. Restart the machine. If problem persists, check motor windings etc.

22:11 NO DRIVE OVERHEAT

The Motor Control Unit indicates error E.ndOH.

Error `MOTOR OVERHEAT` is reset. See also error code 22:9.

Internal message 11.

Recommended actions:

1. Switch off the main power to machine for 5 minutes.
2. Restart the machine.

22:12 POWER UNIT

The Motor Control Unit indicates error E.Pu.

General power circuit fault.

Internal message 12.

Recommended actions:

1. Switch off the main power to machine for 5 minutes.
2. Restart the machine.

22:13 POWER UNIT NOT READY

The Motor Control Unit indicates message nO_PU.

Power circuit not ready or identified by controller.

Internal message 13.

Recommended actions:

1. Wait 2 minutes and try to start again.
2. Switch off the main power to machine for 5 minutes.
3. Restart the machine.

22:14 POWER UNIT INVALID

The Motor Control Unit indicates error E.PUIN.

Power unit invalid. Software version in power module and control board does not match.

Internal message 14.

22:15 LOAD SHUNT FAULT

The Motor Control Unit indicates error E.LSF.

Load-shunt relay is not ready. Appears for a short time during switch-on.

Internal message 15.

If message remains, check following:

1. Wrong input voltage or too low.
2. Braking resistor defective or wrongly connected.
3. Hardware fault in controller.
4. Switch off the main power to machine for 5 minutes.
5. Restart the machine.

22:16 OVERLOAD

The Motor Control Unit indicates error E.OL.

Overload counter has reached 100%.

The error can only be reset after overload counter has reached 0% again. This is indicated by the message E.nOL.
See also error 22:17.

Internal message 16.

Leave machine powered up without running any program for 30 minutes.

1. Check machine is not loaded more than intended.
2. Check motor and drum for mechanical fault. (jamming).
3. Check motor for electrical fault.
4. Switch off the main power to machine for 5 minutes.
5. Restart the machine.

22:17 NO OVERLOAD

The Motor Control Unit indicates error E.nOL.

Overload counter is reset to 0%. See also error 22:16.

Internal message 17.

1. Switch off the main power to machine for 5 minutes.
2. Restart the machine.

22:18 BUS

The Motor Control Unit indicates error E.buS.

Timeout of monitoring time of communication between operator unit and inverter (Watchdog).

Internal message 18.

1. Switch off the main power to machine for 5 minutes.
2. Restart the machine.

22:19 OVERLOAD 2

The Motor Control Unit indicates error E.OL2.

Standstill constant current exceeded.

The error can only be reset after cooling time has elapsed. This is indicated by the message E.nOL2. See also error code 22:20.

Internal message 19.

1. Wait until message 22:20, No ERROR over load 2 is shown.
2. Switch off the main power to machine for 5 minutes.
3. Restart the machine.

22:20 NO OVERLOAD 2

The Motor Control Unit indicates error E.nOL2.

Cooling time has elapsed, error over load 2 is reset. See also error code 22:19

Internal message 20.

1. Restart the machine.

22:21 EEPROM DEFECTIVE

The Motor Control Unit indicates error E.EEP.

EEPROM defective.

Internal message 21.

1. Switch off the main power to machine for 5 minutes.
2. Restart the machine.

Note!

The EEPROM can not be written to, meaning parameter changes are not possible.

22:22 POWER UNIT COMMUNICATION

The Motor Control Unit indicates error E.PUCO.

Parameter value could not be written to power circuit.

Internal message 22.

1. Switch off the main power to machine for 5 minutes.
2. Restart the machine.

22:23 BUS SYNCHRON.

The Motor Control Unit indicates error E.SbuS.
Problem with Bus synchronization.
Internal message 23.

1. Switch off the main power to machine for 5 minutes.
2. Restart the machine.

22:30 MOTOR PROTECTION

The Motor Control Unit indicates error E.OH2.
Electronic motor protection relay has tripped.
Internal message 30.

1. Switch off the main power to machine for 5 minutes.
2. Restart the machine.

22:31 EXTERNAL FAULT

The Motor Control Unit indicates error E.EF.
External fault. This error can be triggered if a digital input is programmed as external error input, and trips. Not used in this application.
Internal message 31.

22:32 ENCODER 1

The Motor Control Unit indicates error E.EnC.
Cable breakage in the encoder. Not used in this application.
Internal message 32.

22:33 POWER FACTOR CONTROL

The Motor Control Unit indicates error E.PFC.
Error in the power factor control.
Internal message 33.

1. Switch off the main power to machine for 5 minutes.
2. Restart the machine.

22:36 NO OVERHEAT POWER MODULE

The Motor Control Unit indicates error E.nOH.
Temperature on heat sink is within permissible range again. See also error 22:8.
Internal message 36.

1. Restart the machine.

22:39 SET

The Motor Control Unit indicates error E.SET.
It has been attempted to access a locked parameter set.
Internal message 39.

Recommended actions:

1. Upgrade machine software to latest version. Restart machine.

22:46 PROTECT. ROT. FORWARD

The Motor Control Unit indicates error E.PrF.
Forward (right) limit switch is activated. Not used in this application.
Internal message 46.

22:47 PROTECT. ROT. REVERSE

The Motor Control Unit indicates error E.Prr.

Reverse (left) limit switch is activated. Not used in this application.

Internal message 47.

22:49 POWER UNIT CODE INVALID

The Motor Control Unit indicates error E.Puci.

Power unit code invalid. During initialization the power unit was not recognized or identified as invalid.

Internal message 49.

Recommended actions:

1. Switch off the main power to machine for 5 minutes.
2. Restart the machine.

22:50 POWER UNIT CHANGED

The Motor Control Unit indicates error E.Puch. Power unit changed.

Power module ID was changed. With a valid power unit the error can be reset by writing to SY.3, see inverter manual.

Mismatch between CPU module and Power module internally in Frequency controlled due to bad contact.

Internal message 50.

Recommended actions:

1. Switch off the main power to machine for 5 minutes.
2. Restart the machine.

22:51 DRIVER RELAY

The Motor Control Unit indicates error E.dri.

Error in Driver relay.

Internal message 51.

Recommended actions:

1. Switch off the main power to machine for 5 minutes.
2. Restart the machine.

22:52 HYBRID

The Motor Control Unit indicates error E.Hyb.

Error hybrid. Invalid encoder interface identifier. Not used in this application.

Internal message 52.

22:54 COUNTER OVERRUN 1

The Motor Control Unit indicates error E.co1.

Counter overflow encoder channel 1. Not used in this application

Internal message 54.

22:55 COUNTER OVERRUN 2

The Motor Control Unit indicates error E.co2.

Counter overflow encoder channel 2. Not used in this application

Internal message 55.

22:56 BRAKE

The Motor Control Unit indicates error E.br.

Error brake. Not used in this application.

Internal message 56.

22:57 INITIALISATION MFC

The Motor Control Unit indicates error E.Inl.

MFC not booted.

Internal message 57.

22:58 OVER SPEED

ERROR over speed in KEB Motor Control Unit.

Internal message 105.

Recommended actions:

1. Restart the machine.

22:87 OVERHEAT INT.

Warning: The Motor Control Unit indicates A.OHI.

Internal overheating in frequency controller. Can only be reset when internal temperature has dropped by 3 °C.

This is indicated by message A.nOHI. See also error code 22:92.

Internal message 87.

Recommended actions:

1. Switch off the main power to machine for 30 minutes.
2. Restart the machine.

22:88 NO OVERHEAT POWER MODULE

Warning: The Motor Control Unit indicates A.nOH.

Warning Overtemperature of power module heat sink is reset. See also error code 22:89.

Internal message 88.

Recommended actions:

1. Restart the machine.

22:89 OVERHEAT POWER MODULE

Warning: The Motor Control Unit indicates A.OH.

Overtemperature of power module heatsink. See also error code 22:88.

Internal message 89.

Recommended actions:

1. Switch off the main power to machine for 30 minutes.
2. Restart the machine.

22:90 EXTERNAL FAULT

Warning: The Motor Control Unit indicates A.EF.

External fault. This warning can be triggered if a digital input is programmed as external error input, and trips. Not used in this application.

Internal message 90.

22:91 NO DRIVE OVERHEAT

Warning: The Motor Control Unit indicates A.ndOH.

Warning Drive motor overheat is reset. See also error code 22:96.

Internal message 91.

Recommended actions:

1. Restart the machine.

22:92 NO OVERHEAT INT.

Warning: The Motor Control Unit indicates A.nOHI.

Overheat internal is reset. See also error code 22:87.

Internal message 92.

Recommended actions:

1. Restart the machine.

22:93 BUS

Warning: The Motor Control Unit indicates A.buS.

Timeout of monitoring time of communication between bus operator and inverter (Watchdog).

Internal message 93.

Recommended actions:

1. Switch off the main power to machine for 5 minutes.
2. Restart the machine.

22:94 PROTECT. ROT. FORWARD

The Motor Control Unit indicates error A.PrF.

Forward (right) limit switch is activated. Not used in this application.

Internal message 94.

22:95 PROTECT. ROT. REVERSE

The Motor Control Unit indicates error A.Prr.

Reverse (left) limit switch is activated. Not used in this application.

Internal message 95.

22:96 DRIVE OVERHEAT

Warning: The Motor Control Unit indicates A.dOH.

Motor temperature too high. Can only be reset when motor temperature has dropped (Resistance at terminals T1/T2 > 1650 Ω) This is indicated by message A.ndOH. See also error code 22:91.

Internal message 96.

Recommended actions:

1. Switch off the mainpower for 30 minutes until motor has cooled down.
2. Restart the machine. If problem persists, check motor windings etc.

22:97 MOTOR PROTECTION

Warning: The Motor Control Unit indicates A.OH2.

Electronic motor protection relay has tripped.

Internal message 97.

Recommended actions:

1. Switch off the main power to machine for 5 minutes.
2. Restart the machine.

22:98 NO OVERLOAD

Warning: The Motor Control Unit indicates A.nOL.

Overload counter is reset to 0%. See also message 22:99.

Internal message 98.

Recommended actions:

1. Restart the machine.

22:99 OVERLOAD 1

Warning: The Motor Control Unit indicates A.OL.

Overload counter has reached 100%.

The warning can only be reset after overload counter has reached 0% again. This is indicated by the message A.nOL. See also message 22:98.

Internal message 99.

Leave machine powered up without running any program for 30 minutes.

Recommended actions:

1. Check machine is not loaded more than intended.
2. Check motor and drum for mechanical fault. (jamming).
3. Check motor for electrical fault.
4. Restart the machine.

22:100 OVERLOAD 2

Warning: The Motor Control Unit indicates A.OL2.

Standstill constant current exceeded.

The message can only be reset after cooling time has elapsed. This is indicated by the message A.nOL2. See also message 22:101.

Internal message 100.

Recommended actions:

1. Wait until message 22:101, NO OVERLOAD 2 is shown.
2. Restart the machine.

22:101 NO OVERLOAD 2

Warning: The Motor Control Unit indicates A.nOL2.

Cooling time has elapsed, error over load 2 is reset. See also message 22:100.

Internal message 101.

Recommended actions:

1. Restart the machine.

**22:102 SET**

Warning: The Motor Control Unit indicates error A.SET.

It has been attempted to access a locked parameter set.

Internal message 102.

Recommended actions:

1. Upgrade machine software to latest version.
2. Restart the machine.

DRUM MOTOR OBIWAN

23:1 HEATSINK TOO HOT

This error code is generated by the MCU for drum motor.

There is a temperature sensor (NTC) mounted on the MCU cooling flange next to the power transistors in the output stage. If the temperature of the cooling flange gets too high ($> 100^{\circ}\text{C}$) the error code will be set to protect the transistors.

The cause of high cooling flange temperature can be e.g. a stiff drum in combination with intensive use and high ambient temperature. There may also be an error in the motor (sticking bearings or short circuit in windings, which impairs the efficiency of the motor). When temperature has decreased below 85°C , the error can be reset on the selector button.

Recommended actions:

1. Make sure the drum turns easily.
2. Check the value on the error code counter for the error code.
3. Check the last 8 MCU error codes.
4. Start a 90°C normal program with load on continuous operation and measure the temperature of the motor and MCU.
5. Replace the defective part.

23:2 MOTOR TOO HOT

This error code is generated by the MCU for the drum motor.

The MCU monitors the motor temperature in two ways.

1. The MCU calculates the motor winding resistance by measuring current and voltage. The winding resistance can then be converted to a temperature, since the winding resistance at 20°C and the temperature coefficient are known. If the average value of the four latest temperature readings is higher than the maximum motor temperature (e.g. 130°C), the error code will be shown. When temperature has decreased below 130°C , the error can be reset on the selector button.
2. The MCU monitors the input from motor over heat protection. If this input is open circuit, the error will be shown. When input is closed again, the error can be reset on the selector button.

Possible causes:

The cause of high motor temperature can be a stiff drum, possibly in combination with intensive use and high ambient temperature. There may also be an error in the motor (sticking bearings or short circuit in windings, which impairs the efficiency of the motor). There could also be a contact error in the connectors between the MCU and the motor or an error in the motor cable. An error in MCU temperature measurement circuits can also occur.

Recommended actions:

- Make sure the drum turns easily.
- Check the status of motor over heat protection.
- Check the value on the error code counter for the error code.
- Check the last 8 MCU error codes.
- Measure the three phases to the phase resistors on the MCU motor connector (disconnect MCU and take the reading in the cable connector) to make sure they are the same.
- Start a 90°C normal program with load on continuous operation and measure the temperature of the motor and MCU.
- Replace the defective part.

23:3 NO INTERLOCK

This error code is generated by the MCU for drum motor.

The MCU must be powered with 230V / 50 or 60 Hz on the interlock input in order to drive the motor. This signal is a confirmation that the door is closed and locked.

MCU receives its commands to rotate the drum from the CPU via a serial communication link between the MCU and CPU. Since the CPU also has access to the interlock signal, the CPU must never send a run command to the MCU if the interlock signal is missing. If this does happen, this error code will be shown.

Possible causes:

The cause of this error code being activated can be e.g. a break in the cable leading the interlock signal to the MCU. There may also be an error in the connector in the door lock, which connects 230V / 50 Hz to the interlock signal. An error in the interlock circuits of the MCU can also set this error code.

Recommended actions:

1. Use a multimeter to check that there is 230V present on the MCU Interlock input when the door lock is activated. Read also bit 1 in the second byte under `MCU STATUS` in the service program (the bits are numbered from 0 to 7 where bit 0 is on the far right). If bit 1 in the second byte is 1 then the lock is open, while a 0 indicates that the lock is closed.
2. Replace the defective part.

23:4 NO COMMUNICATION

This error code is generated by the MCU for drum motor.

MCU detects there is there is a problem in communication with CPU.

Possible causes:

Bad contact in harness or connectors between CPU and MCU.

Recommended actions:

1. Check wiring, connections between CPU and MCU.

23:5 MOTOR SHORT CIRCUIT

This error code is generated by the MCU for drum motor.

The MCU reads the power consumption of the motor continuously. If the current for some reason exceeds a predetermined limit, the MCU will cut the current to the motor, and the error code will be shown.

Possible causes:

This error code can be activated for a number of reasons:

- Short circuit in motor. Measure motor windings with a Motor Tester.
- Short circuit internally in motor winding (impaired efficiency, higher current consumption).
- Short circuit in motor cables.
- Short circuit in connectors.
- Drops of water causing short circuits in the motor connector.
- Short circuit in the MCU output transistors.
- Bad contact in interlock signal.

Recommended actions:

1. If the error is a stable one, it is generally not difficult to locate the defective unit through resistance measurement and testing with the service program. Measure motor windings with a Motor Tester.
2. Further information can be obtained by studying the contents of `MCU ERROR LOG 1` and `MCU ERROR LOG 2`.
3. Review following:
4. `SHORT CIRCUIT 1` (specifies how many times the current limit has been exceeded).

23:6 INTERLOCK HARDWARE

This error code is generated by the MCU for drum motor.

The MCU must be powered with 230V / 50 or 60 Hz on the interlock input in order to drive the motor. The interlock circuits in the MCU have been split into two channels so that a component error in MCU cannot give a false confirmation that the door is locked. These two channels are checked against each other. If this check gives an incorrect result this error code will be shown.

Possible cause:

The reason for this error code being activated can be attributed to an error in the interlock circuits in motor control.

Recommended actions:

1. Replace MCU.

23:7 LOW DC VOLTAGE

This error code is generated by the MCU for drum motor.

The MCU constantly measures the voltage over the mains input. If the voltage drops below a predefined limit, the MCU will shut off the current to the motor and the error code will be shown.

The error can be reset by pressing selector button when voltage is within range again.

The reason for this error code being activated can be low mains voltage or that the machine's on/off switch has been operated in an unsuitable manner. Further information can be obtained by studying the contents of MCU ERROR LOG 1 and MCU ERROR LOG 2:

- UNDERVOLTAGE 1 (specifies how many times the voltage has dropped below the limit).
- LAST FAULT CODE N/8 (shows the 8 latest error codes) Undervoltages can be registered even during normal operation. Consequently, a small number of registrations need not mean that there is an error in the MCU.

Recommended action:

1. Check that the supply voltage is stable and never drops below nominal voltage - 10%.
2. Check the fuses and cables.
3. Check the supply voltage in the network cabling and at the MCU in the machine.

23:8 HIGH DC VOLTAGE

This error code is generated by the MCU for drum motor.

The MCU constantly measures the voltage over the mains input. If the voltage exceeds a predefined limit, the MCU will shut off the current to the motor, and the error code will be shown.

The error can be reset by pressing selector button when voltage is within range again.

Possible causes:

Fluctuating mains voltage.

Recommended action::

1. Check that the supply voltage is stable and never exceeds nominal voltage + 6%.

23:12 NO PARAMET. SET IN MCU

This error code is generated by the MCU for drum motor.

The MCU contains several different parameter sets for different motors. During power up the control system checks that the correct parameter set digit is written into the MCU. If not, the control system will write down the parameter set digit defined in fixed configuration.

If the MCU discovers that no parameter set value is written down into the MCU, the error code will be shown.

Possible causes:

This can be caused by wrong software in CPU or wrong MCU for the current machine.

Recommended actions:

1. Make sure correct machine software and correct MCU are used.

23:13 UNBALANCE

This error code is generated by the MCU for drum motor.

The MCU monitors the unbalance switch status. If the status is active already at program start, this error code is shown.

23:15 MOTOR NOT FOLLOW

This error code is generated by the MCU. The MCU continuously estimates the motor speed. If the estimated speed is less than 180 rpm 10 seconds after drive command, or higher than 180 rpm 60 seconds after stop command, the error will be shown.

Possible causes:

- Break in one of the phases to the motor (cables or connectors). This error can be suspected if the motor does not rotate for 10 seconds (the motor will not start with only two phases).
- Check that the drum can be rotated easily.
- Check motor windings for open circuit using a Motor tester.

Further information can be obtained by studying the contents of `MCU ERROR LOG 1` and `MCU ERROR LOG 2`. Study the following:

- `MOTOR NOT FOLLOW` (specifies how many times this error code has occurred).
- `LAST ERROR CODE N/8` (shows the 8 latest error codes).

Recommended action:

1. Replace the defective part.

23:255 UNDEFINED ERROR

This error code is generated by the MCU. The MCU reports an error that is not defined.

FAN MOTOR COMMON

30:1 O.H. FAN MOTOR

This error code will be shown if the control system detects that the input OH FAN MOTOR is deactivated during program run.

The overheating protection is automatically restored. When the overheating protection is restored the error code is automatically reset and the ongoing program will continue. A long press on the control knob/start button will make the control system reset and the ongoing program will be ended.

The error code can be triggered if:

- The motor is very warm. Check that the vent holes in the motor are not covered.

If the overheating protection is not triggered, but there is still an error code:

- Check the harness, connectors and functions by reading the electrical schematic and by using the `SHOW INPUTS` menu when the machine is in service mode.

INTERNAL COM.

40:1–40:10 I/O INTERLOCK Axxx

This error code will be shown if the control system detects that the input IO INTERLOCK is not active. I/O unit designation, Axxx, that is shown in the error description is according to electric schematics and electrical component list.

Recommended actions:

1. Check that door is actually locked.
2. Check DLCU status in service mode for more information on possible causes.
3. Check P-bus connectors on I/O board for present interlock signal.
4. Check that D-bus connector is fitted correctly with regards to the rib on the connector and the slot in the plastic cover of the I/O board.

40:11–40:20 I/O COMMUNICATION Axxx

The error code is shown if the control system can not communicate with one or several I/O units on D-bus. I/O unit designation, Axxx, that is shown in the error description is according to electric schematics and electrical component list. Errors are related to the D-Bus communication port between CPU and the different I/O units in the machine. The error code is shown if the control system has lost communication with one or more I/O units for a certain time.

If there is communication between the I/O unit and control system the LED next to the service button will flash.

If there is no communication to the I/O unit but power, the LED will light when the button is pressed on the I/O board (all I/O boards except for I/O unit type 6).

Possible causes:

- Mistake when configuring I/O unit address at set up. Button on wrong I/O unit pressed during config.
- Two or more I/O units have the same I/O addressing.
- Bad or intermittent contact in D-Bus wiring between I/O units and CPU or between I/O units.
- Squeezed or shorted D-bus cables (shorted to ground).
- An old version of an I/O unit is fitted in the machine that do not support Compass Pro. Check part number compared to original I/O board or spare parts list.

Recommended actions:

1. Check that all I/O units are configured in I/O CONFIGURATION menu when the machine is in service mode. Alternatively use Common Service Tool to get a overview of the I/O unit configuration. Use the electric schematic to find correct I/O board to address.
2. If all I/O units are present in the list, check the LED as above, harness, connectors and functions by reading the electrical schematic.
3. Check that the I/O units fitted in the machine supports Compass Pro. Check part number compared to original I/O board or spare parts list.
4. Update the machine software to latest available version.

40:21 I/O COMMUNICATION

Only on Barrier washer.

The error code is activated if the control system no longer can communicate with Barrier I/O unit or if the communication is intermittent. I/O unit designation that is shown in the error description is according to electric schematics and electrical component list.

Barrier I/O board is connected to M-COM port on CPU in paralell with the MCU for drum. Electrical interface is RS-485. The error code is shown if the control system has lost or only have intermittent communication with the I/O unit.

Possible causes:

- Bad contact in harness or connectors between CPU/MCU and I/O unit.
- The I/O board is incorrectly configured on DIP switches (SW210 and SW202)

Recommended actions:

1. Check wiring, connections configuration of I/O unit according to service manual.

40:22 I/O BOARD MISHMASH

The error code is shown if wrong Type of I/O unit is fitted.

Could also occur if addressing of the I/O units is made in a incorrect way.

After addressing of I/O units the CPU reads the Type of each unit.

If there is a mismatch between what the Type of I/O unit the CPU finds, and what the I/O unit type the software configuration expects, the error will be shown.

Machine will not run until problem is solved. There are two exceptions: I/O type 1 can be used when I/O type 11 is expected, but not oposite. I/O type 8 can be used when I/O type 81 is expected, but not oposite.

Possible causes:

- When addressing the I/O units the operator has pressed a the button on the wrong I/O unit.
- Wrong type of I/O unit if fitted in the machine.
- Two I/O units have got the same adress.

Recommended actions:

1. Readdress all I/O units.

Use I/O CONFIGURATION function in service mode.

Alternatively use Common Service Tool, I/O addressing function.

2. Use the electric schematic to find correct I/O board to address.
3. Use Common Service Tool, I/O addressing function to get best overview/visualization of the problem.



PLATON SERVICE

8 (800) 500-34-41

www.platonservice.com

INTERNAL COM. I/O TYPE 10

41:1 CHARGE CIRCUIT

The DLCU on I/O board type 10 contains an arming circuit that is charged when the door lock coil is to be activated. For safety reasons, this arming circuit must be discharged when the door lock coil is not to be activated. If the arming circuit for operating the door lock is charged when it is not supposed to be, an error message will be sent to the CPU. CPU reads the error message when the door is locked and unlocked and generates an error. The error is ignored between these two occasions.

Possible causes:

- The error can be caused by overloads and/or defective components in the DLCU on I/O board type 10.

For pocket machine, this error relates to I/O board type 10 on "Loading side".

See also corresponding error 41:21 for I/O type 10 on "Unloading side".

41:2 SET SIGNAL NO TACHO. WAIT 5 MINUTES

The DLCU on I/O board type 10 counts the tacho pulses from the motor in order to guarantee that the drum is standing still before the door is opened. To ensure that the signal from the tacho generator is working correctly, DLCU compares the tacho signal with a digital bit value from the CPU, which is due to the CPU having activated the motor (See DLCU status indication).

Error will reset automatically after 5 minutes and door will then unlock. The error message is filtered in such a way that: - the digital bit value should have been active for more than 2 seconds - when the digital bit value goes low, tacho signal must be present - test is only performed when door is about to unlock.

Possible causes:

- Open or shorted circuit to the tacho sensor.
- Damaged tacho sensor or magnet.
- Secondary fault due to a error in the motor system.

Recommended actions:

1. Check that motor is actually running.
2. Check there is voltage from tachometer output when motor is running.
3. Check that rotation is detected in DLCU status for the I/O type 10 board.

For pocket machine, this error relates to I/O board type 10 on "Loading side".

See also corresponding error 41:22 for I/O type 10 on "Unloading side".

41:3 ACTUATOR CIRCUIT

The DLCU on I/O board type 10 continuously controls the circuit to the door lock solenoid. DLCU can detect an open circuit (>50 k Ω) but not a short circuit.

If case of an open circuit, CPU will show the error.

The error will disappear if the error is removed.

Possible causes:

- Open circuit to the door lock solenoid.
- Open circuit in the door lock solenoid.
- Error or open circuit in the I/O board 10 circuits.

Recommended actions:

1. Check resistance in door lock solenoid circuit. Correct reading is approx. 6 Ω .
2. Check if error "AC" still remains in DLCU status.

For pocket machine, this error relates to I/O board type 10 on "Loading side".

See also corresponding error 41:23 for I/O type 10 on "Unloading side".

41:21 CHARGE CIRCUIT

Only on Pocket washer.

Pocket washer uses two I/O boards type 10, one for the "Loading side" and one for the "Unloading side".

This error relates to I/O board type 10 on "Unloading side".

See also corresponding error 41:1 for I/O type 10 on "Loading side".

The DLCU on I/O board type 10 contains an arming circuit that is charged when the door lock coil is to be activated. For safety reasons, this arming circuit must be discharged when the door lock coil is not to be activated. If the arming circuit for operating the door lock is charged when it is not supposed to be, an error message will be sent to the CPU. CPU reads the error message when the door is locked and unlocked and generates an error. The error is ignored between these two occasions.

Possible causes:

- The error can be caused by overloads and/or defective components in the DLCU on I/O board type 10.

41:22 SET SIGNAL NO TACHO. WAIT 5 MINUTES

Only on Pocket washer.

Pocket washer uses two I/O boards type 10, one for the "Loading side" and one for the "Unloading side".

This error relates to I/O board type 10 on "Unloading side".

See also corresponding error 41:2 for I/O type 10 on "Loading side".

The DLCU on I/O board type 10 counts the tacho pulses from the motor in order to guarantee that the drum is standing still before the door is opened. To ensure that the signal from the tacho generator is working correctly, DLCU compares the tacho signal with a digital bit value from the CPU, which is due to the CPU having activated the motor (See DLCU status indication).

Error will reset automatically after 5 minutes and door will then unlock.

The error message is filtered in such a way that:

- The digital bit value should have been active for more than 2 seconds.
- When the digital bit value goes low, tacho signal must be present.
- Test is only performed when door is about to unlock.

Possible causes:

- Open or shorted circuit to the tacho sensor.
- Damaged tacho sensor or magnet.
- Secondary fault due to a error in the motor system.

Recommended actions:

1. Check that motor is actually running.
2. Check there is voltage from tachometer output when motor is running.
3. Check that rotation is detected in DLCU status for the I/O type 10 board.

41:23 ACTUATOR CIRCUIT

Only on Pocket washer.

Pocket washer uses two I/O boards type 10, one for the "Loading side" and one for the "Unloading side".

This error relates to I/O board type 10 on "Unloading side".

See also corresponding error 41:3 for I/O type 10 on "Loading side".

The DLCU on I/O board type 10 continuously controls the circuit to the door lock solenoid. DLCU can detect an open circuit (>50 k Ω) but not a short circuit. If case of an open circuit, CPU will show the error. The error will disappear if the error is removed.

Possible causes:

- Open circuit to the door lock solenoid.
- Open circuit in the door lock solenoid.
- Error or open circuit in the I/O board 10 circuits.

Recommended actions:

1. Check resistance in door lock solenoid circuit. Correct reading is approx. 6 Ω .
2. Check if error "AC" still remains in DLCU status.

INTERNAL COM. I/O TYPE 6

42:1 I/O TYPE 6 INTERNAL ERROR

I/O unit type 6, reading of internal analog values out of range.

Possible causes:

- Intermittent error in wiring to I/O type 6 unit.
- Internal error in I/O type 6.

Recommended actions:

1. Switch power off for 1 minute and try again.
2. If problem remains, replace defective part.

42:2 I/O TYPE 6 POSITION TEST

Position test is used to verify that I/O type 6 unit is correctly assembled and fixed in the expected position.

Recommended actions:

1. Check that I/O type 6 unit is assembled and fixed in correct position.

42:3 I/O TYPE 6 EXTRACT TEST

I/O unit type 6 is not able to read any or too low values during extraction.

Recommended actions:

1. Check that I/O unit type 6 unit is assembled and fixed in correct position.
 2. Put some unbalance in drum and run motor to extraction speed in service program.
- Check analog input readings for I/O 6.

EXTERNAL COM. PAYMENT

51:22 NO CBT COMMUNICATION PRESS TO RETRY

Machine connected to payment system using serial communication to machine.

Cause:

- Communication has been established once and then interrupted.

Recommended actions:

1. Check electrical connections between CPU and payment system.
2. If running in a network, check network cables between machine and payment system.
3. Check that payment system is operational.
4. Check that payment system and machine is configured to the same Machine adress (Config 1).
5. To reset machine to working state without repairing payment system, use Reset CBT communication in service mode. (Requires password).

EXTERNAL COM. CMIS

52:1 CMIS COMMUNICATION ERROR

Communication between machine and CMIS computer has been interrupted.

The warning will be shown at program start for 5 seconds, the next 5 programs. It is then removed automatically.

After the warning message has disappeared the machine will start, but no CMIS data statistics/data will be logged.

Possible causes:

- If using ELS Common Service Tool process viewer and cable has been unplugged before process viewer has been stopped, this warning will occur.
- If running with ELS CMIS and communication is interrupted to PC, warning will occur.

Recommended actions:

1. If using ELS CST, reconnect, enter Process viewer and select function "Reset MIS communication".

2. If using ELS Network and CMIS:

Check ELS network cable between machine and PC.

Check that CMIS application is active and running normally.

For CMIS: The machine can operate but statistics will be affected and data will be lost.

52:2 DMIS COMMUNICATION ERROR

This is a warning message that will be shown for 5 seconds if there is a problem in DMIS communication, i.e. the communication between the machine and an external detergent dosing system.

Warning is shown if system has been up running once and then is interrupted or working intermittent.

The warning will be shown at program start for 5 seconds, the next 5 programs. It is then removed automatically.

After the warning message has disappeared the machine will start, but there is a risk the wash will run without any external detergent dosing.

Possible causes:

- The external dosing system has been disconnected, switched off or broken.
- Machine address in machine has been changed and this is also used by external dosing system.

Recommended actions:

1. Check connections, cables or network between machine and detergent dosing system.

2. Consult the supplier for external dosing system.

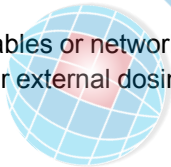

INTERNAL

60:5 FATAL ERROR INVALID RUNNING MODE

The control system has an internal error during memory read.

Recommended actions:

1. Press the control knob/start button to retry.
2. If problem persists, upload new software.

60:11 FATAL ERROR EXTERNAL FLASH WRITE

The control system has an internal error during memory read.

Recommended actions:

1. Press the control knob/start button to retry.
2. If problem persists, upload new software.

60:17 FATAL ERROR INVALID OPTION

The control system has an internal error during memory read.

Recommended actions:

1. Press the control knob/start button to retry.
2. If problem persists, upload new software.

60:18 FATAL ERROR INVALID MODULE

The control system has an internal error during memory read.

Recommended actions:

1. Press the control knob/start button to retry.
2. If problem persists, upload new software.

60:28 FATAL ERROR INVALID COIN INPUT

The control system has an internal error during memory read.

Recommended actions:

1. Press the control knob/start button to retry.
2. If problem persists, upload new software.

60:29 FATAL ERROR INVALID FONT

The control system has an internal error during memory read.

Recommended actions:

1. Press the control knob/start button to retry.
2. If problem persists, upload new software.

15 Maintenance

15.1 Clean the fan, the exhaust duct and the fresh-air intake to the room

Check that the following are not clogged by lint and dust or otherwise blocked and clean with a vacuum cleaner:

- The fan. **Be careful not to damage the fan.**
- Exhaust duct.
- Fresh-air intake to the room.

Check that the exhaust system connections are tight.

15.2 Clean the glide surface for the RMC graphite collector

Clean the glide surface for the RMC graphite collector on the outside of the drum (A).

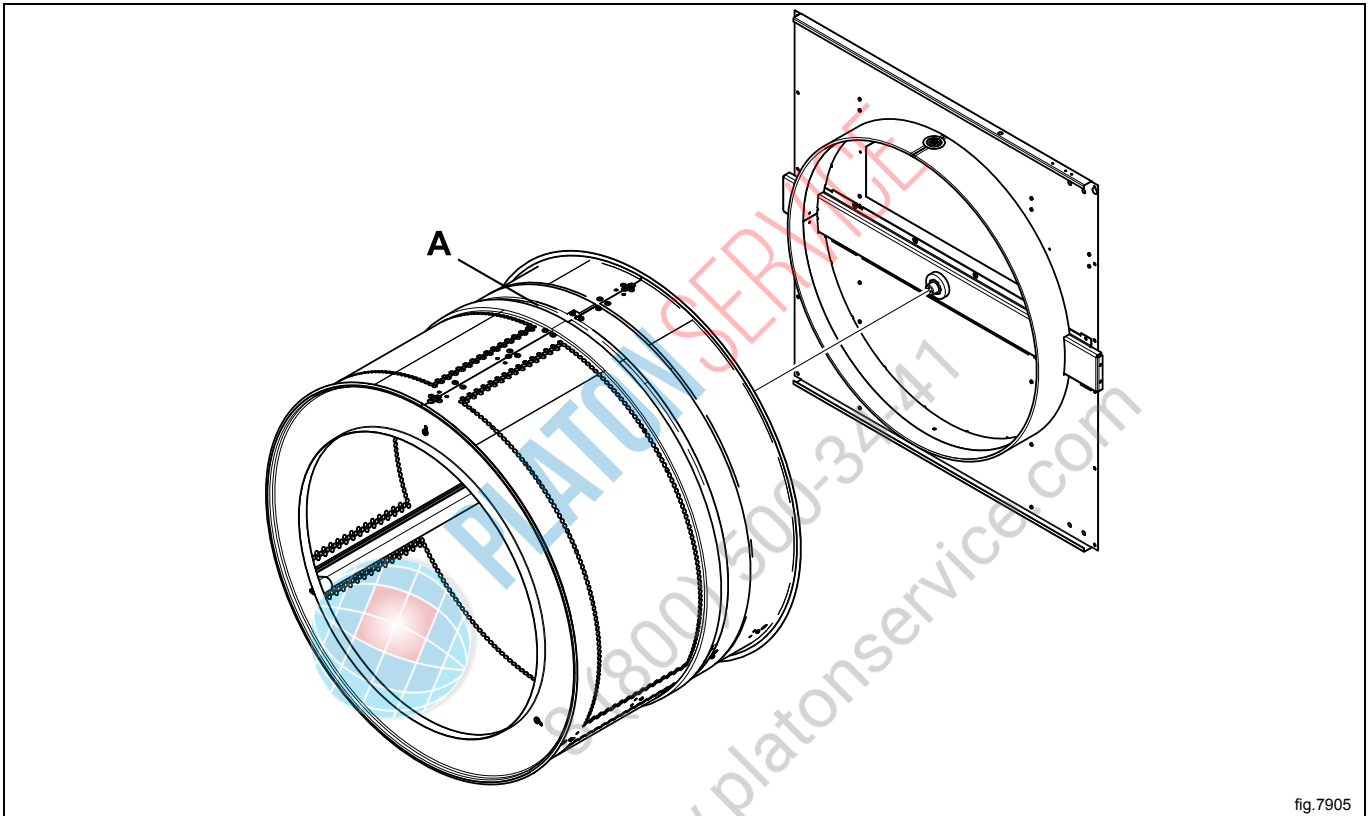

15.3 Clean the area around the drum

Disconnect the power to the machine.

Demount the hinges and remove the door. Remove the upper hinge first.

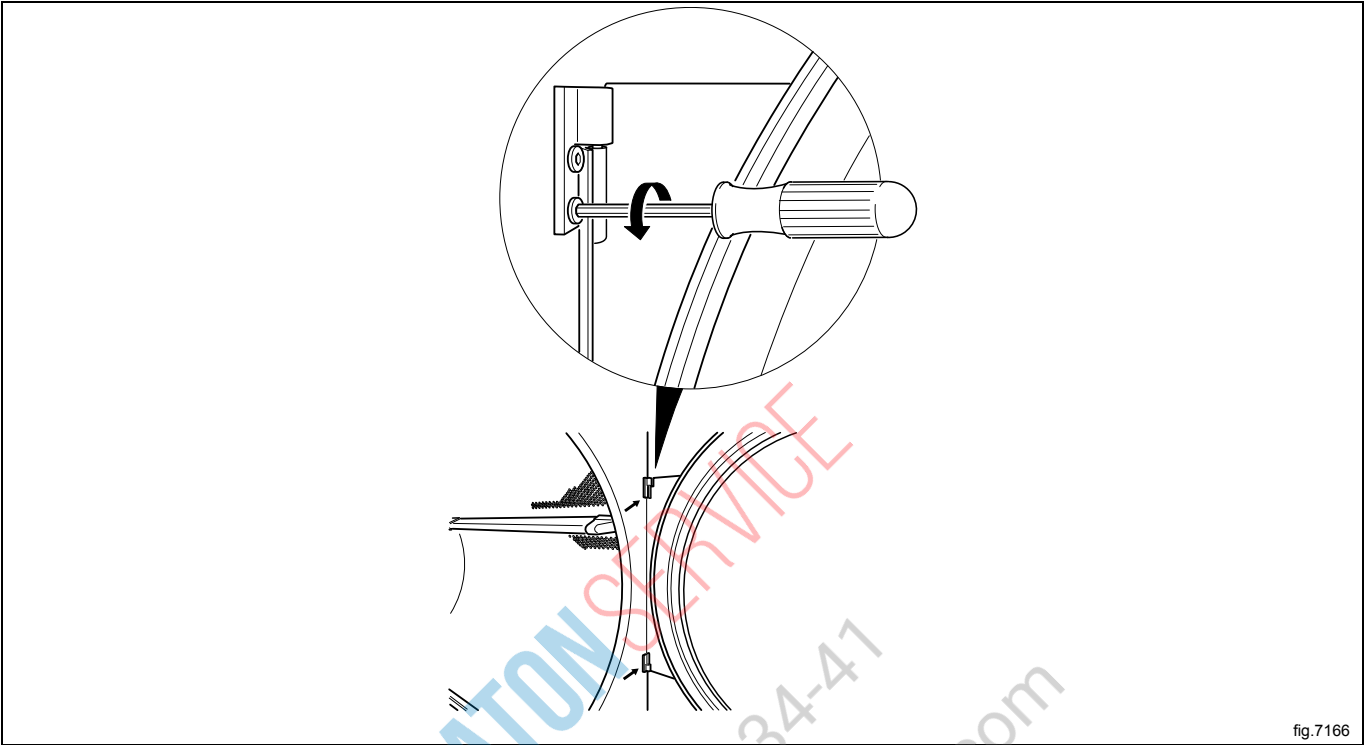

Remove the screws on the front panel and carefully loosen the panel. Push the door switch cable down through the hole in order to access the cable and then disconnect the cable. Remove the panel.

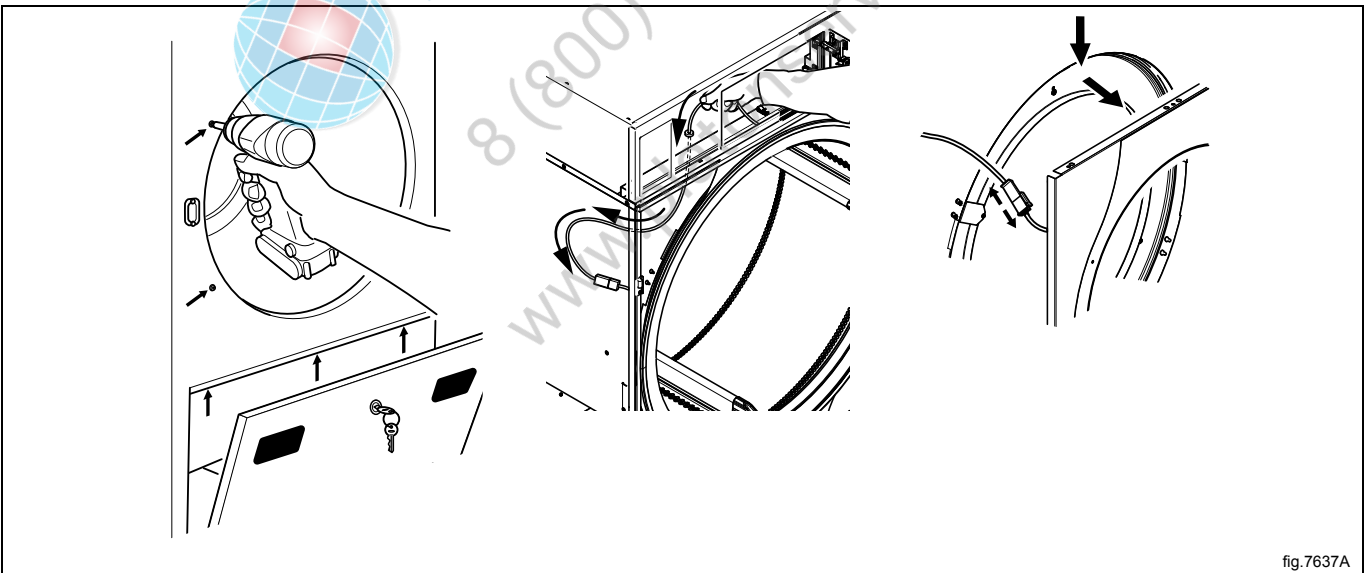

Remove all lint around the drum and in the area over the drum with a vacuum cleaner.
Check the support rollers (A) and replace if necessary.

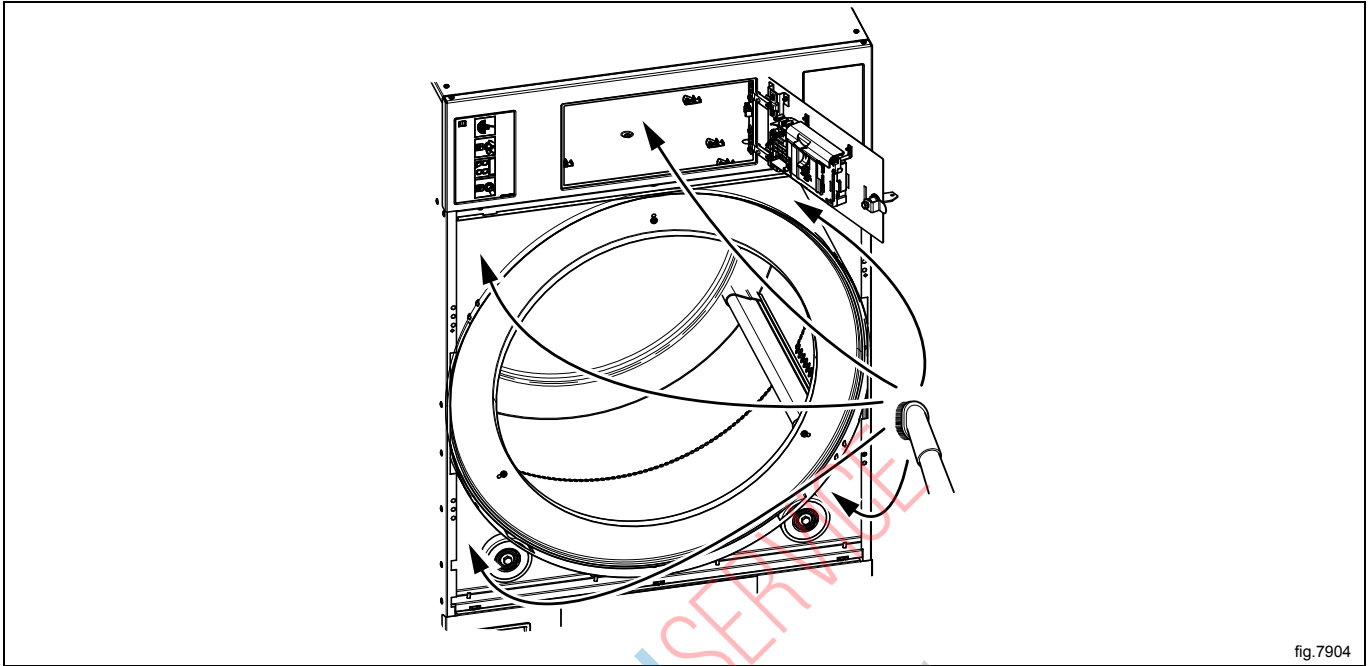

fig.7904

Connect the door switch cable and push the cable in over the drum and pull it upwards.

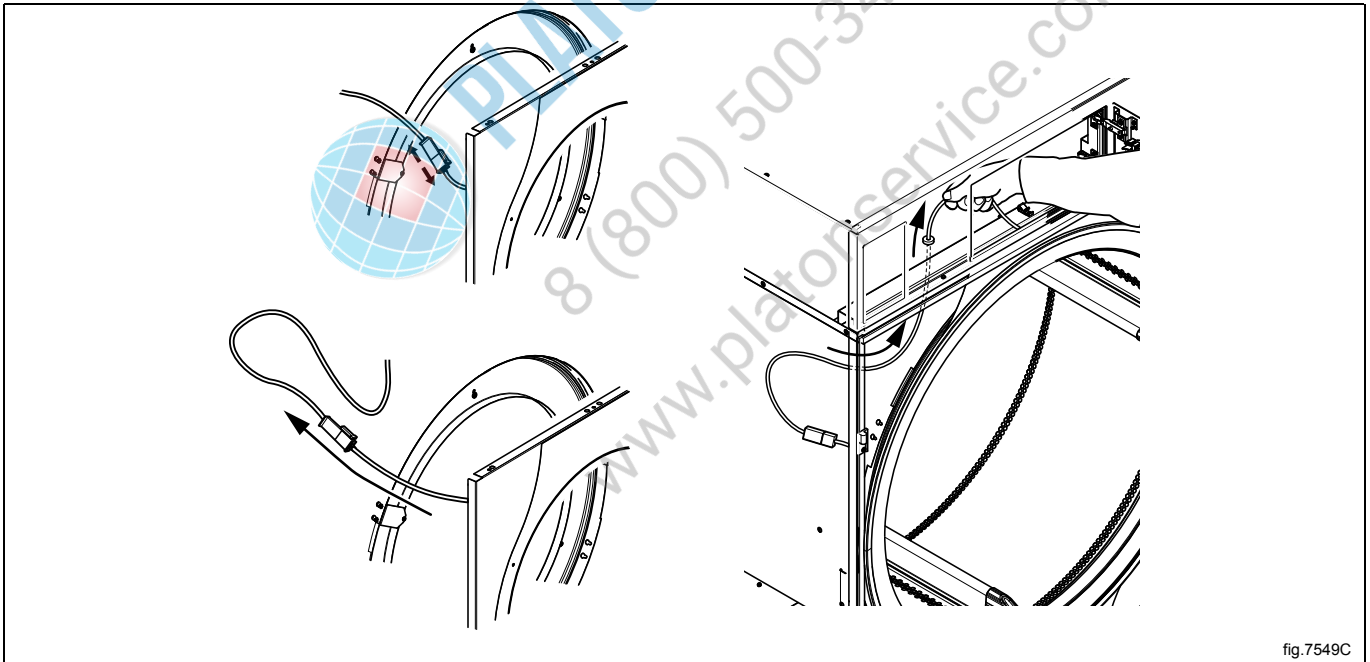

fig.7549C

Remount the front panel.



Ensure that the door switch cable does not get damaged when remounting the front panel.



Remount the door.

15.4 Clean the motors

Disconnect the power to the machine.

Demount the rear panel.

Clean the fan wheel and the motor (on machines with reversing) with a vacuum cleaner.

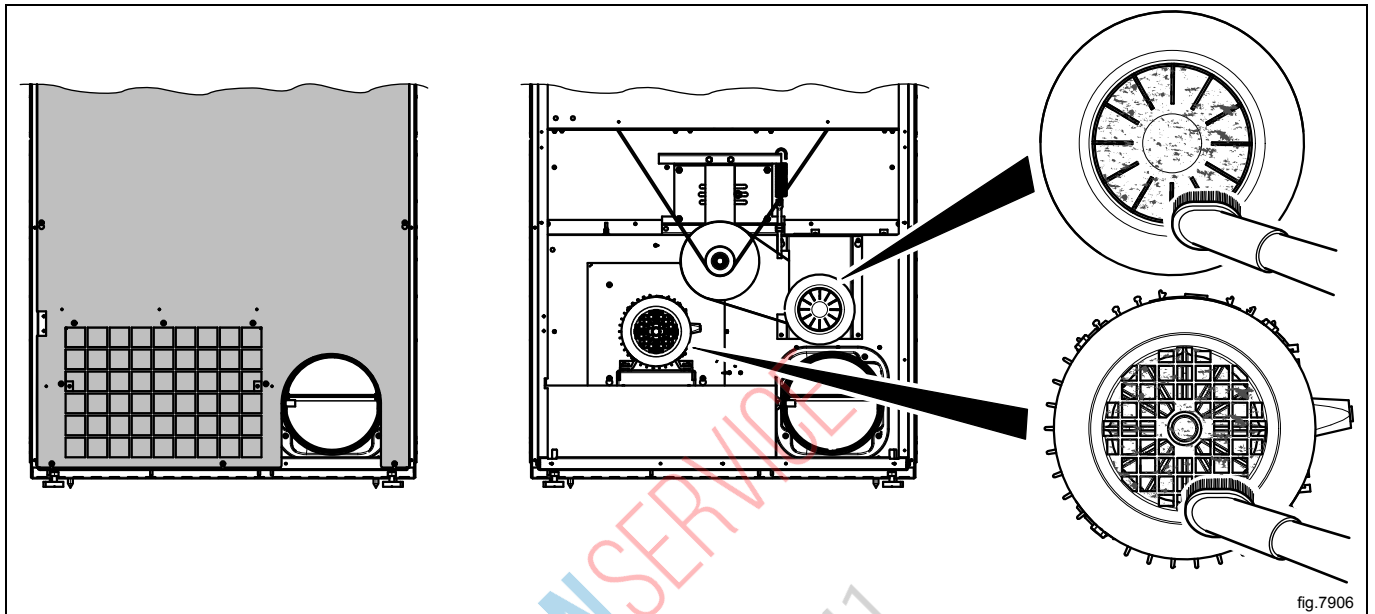

Remount the rear panel.



PLATON SERVICE
8 (800) 500-34-47
www.platonservice.com

15.5 Check the belt tension

Disconnect the power to the machine.

Demount the rear panel.

Check that the spring is tightened and that the length (x) is $135 \text{ mm} \pm 5 \text{ mm}$.

A = Machine with reversing.

B = Machine without reversing.

Adjust if necessary.

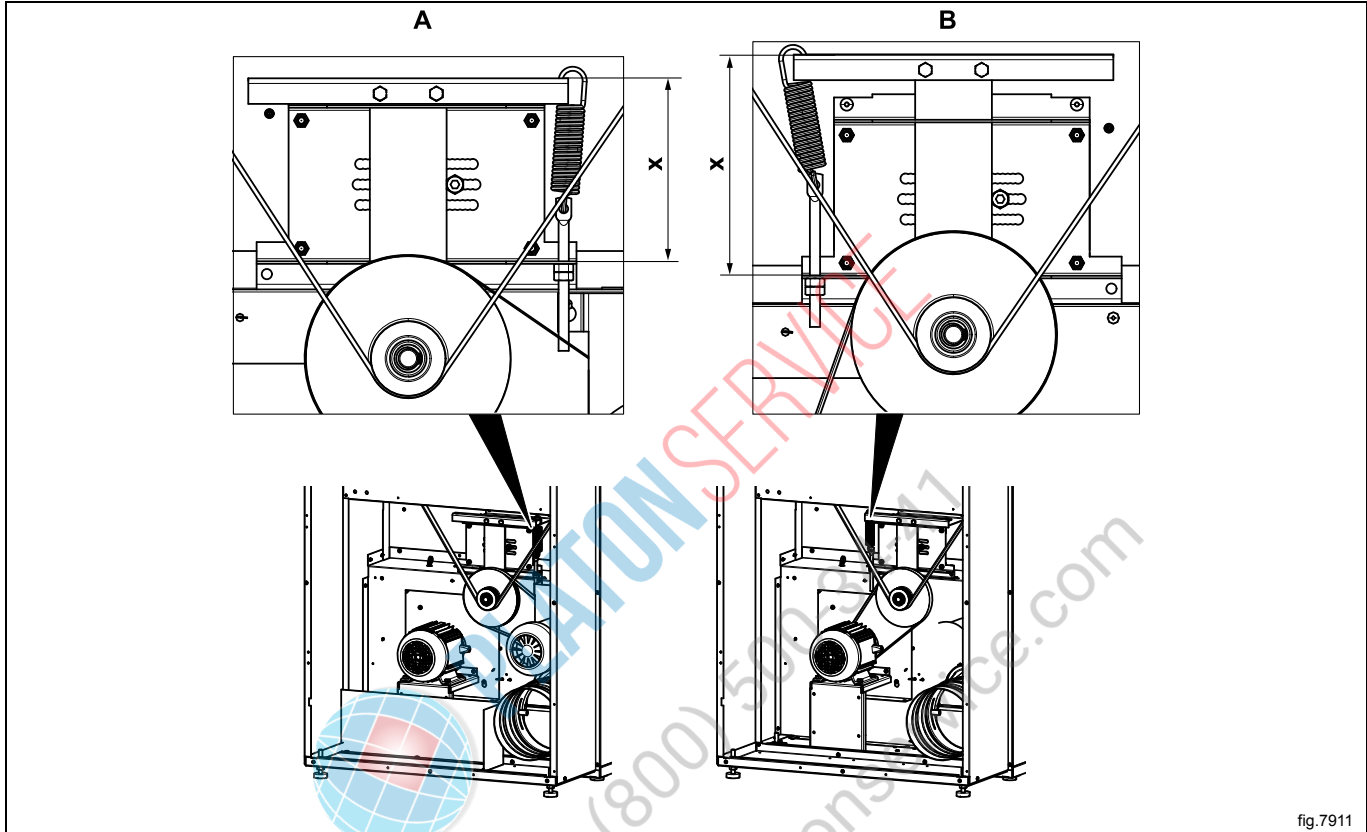

fig.7911



PLATONSERVICE

8 (800) 500-34-47

www.platonservice.com



Electrolux Laundry Systems Sweden AB
341 80 Ljungby, Sweden
www.electrolux.com/professional

Share more of our thinking at www.electrolux.com